

SM, CE, BP Series Electric Heat Kit

HK050 | HK100 | HK150 | HK200 |



BOSCH

Installation Manual

8 733 942 571 (2016/07)

CONTENTS

Key to Symbols.....	3
Safety Warnings	3
Introduction	4
Pre installation	4
Unpacking and inspection.....	4
Components List.....	4
Required Tools.....	4
Electric Heat Kit.....	5
Installation Hardware	5
Installation Wiring.....	7
Electric Heat Electric Data Table.....	10
Thermostat Wire Connections.....	10
Site Line Voltage Connection.....	11
Wiring Diagram Replacement.....	11
Unit Start Up.....	11
Information On Decommissioning.....	11
Wiring Diagrams	12
Ebox Layouts.....	17
Notes.....	19

KEY TO SYMBOLS

Warnings



Warnings in this document are identified by a warning triangle printed against a grey background. Keywords at the start of the warning indicate the type and seriousness of the ensuing risk if measures to prevent the risk are not taken.

The following keywords are defined and can be used in this document:

- **NOTICE** indicates a situation that could result in damage to property or equipment.
- **CAUTION** indicates a situation that could result in minor to medium injury.
- **WARNING** indicates a situation that could result in severe injury or death.
- **DANGER** indicates a situation that will result in severe injury or death.

Important Information



This symbol indicates important information where there is no risk to property or personal injury.

SAFETY WARNINGS



WARNING: Installation and servicing of this equipment can be hazardous due to system pressure and electrical components. Only trained and qualified personnel should install, repair, or service the equipment.



WARNING: Before performing service or maintenance operations on the system, turn off main power to the unit. Electrical shock could cause personal injury or death.



WARNING: When working on equipment, always observe precautions described in the literature, tags, and labels attached to the unit. Follow all safety codes. Wear safety glasses and work gloves. Use a quenching cloth for brazing, and place a fire extinguisher close to the work area.

NOTICE: To avoid the release of refrigerant into the atmosphere, the refrigerant circuit of this unit must be serviced only by technicians who meet local, state, and federal proficiency requirements.

NOTICE: All refrigerant discharged from this unit must be recovered WITHOUT EXCEPTION. Technicians must follow industry accepted guidelines and all local, state, and federal statutes for the recovery and disposal of refrigerants. If a compressor is removed from this unit, refrigerant circuit oil will remain in the compressor. To avoid leakage of compressor oil, refrigerant lines of the compressor must be sealed after it is removed.

NOTICE: To avoid equipment damage, DO NOT use these units as a source of heating or cooling during the construction process. Doing so may affect the unit's warranty. The mechanical components and filters will quickly become clogged with construction dirt and debris, which may cause system damage.



HK Series Heater Package can only be installed on single phase units



A heater collar is installed in the unit, no need to order separately.



A heat pump thermostat with supplemental electric heat feature is required to operate the system when this kit is installed.

INTRODUCTION

Bosch HK Series Heater Package is a field installable electric resistance heater kit designed for the SM, CE, BP series heat pumps.

The HK series heater package requires separate electrical service connection, independent from the heat pump's power supply. Hence, installation of this Heater Package will convert the Heat Pump into a two point power connection.

The HK series Heater Package is available in several kW capacities. Unit tonnage vs Heater Package capacity compatibility table is below. The HK series Heater Package can be installed on Vertical (VT), Horizontal [end blow only] (HZ) and Counter-flow (CF) units. The eighth and ninth characters of the unit model signify the configuration. Example: SM024-1VTC.

HEATER COMPATIBILITY				
Unit Model	HK050-1201 (5kW)	HK100-1201 (10kW)	HK150-1201 (15kW)	HK200-1201 (20kW)
SM024	X	X+		
SM036	X	X	X+	
SM048	X	X	X	X+
SM060	X	X	X	X
SM070	X	X	X	X
CE025	X	X		
CE035	X	X		
CE049	X	X	X	
CE061	X	X	X	X
CE071	X	X	X	X
BP018	X			
BP024	X	X		
BP030	X	X		
BP036	X	X	X	
BP042	X	X	X	
BP048	X	X	X	X
BP060	X	X	X	X

x Heater Package Compatibility
+ Required constant ECM airflow motor

PRE-INSTALLATION

Unpacking and Inspection

1. Unpack the heater kit and inspect for contents and condition. If any part or the kit appears damaged (i.e.: broken heater elements, damage relays) or missing, do not attempt to install the damaged kit. Contact your local distributor for further help.
2. Ensure that the heater kit package includes the following components. Contact your local distributor for further help.

Components List

- Pre-wired heater electrical box (including fuses on HK150 and HK200)
- Heater elements
- Heater element(s) protective metal cover
- Wire harness pre-wired at one end.
- New wiring diagram
- Adhesive back electrical data label
- Clear hardware accessory bag containing:
 - Heater element mounting 3/8 Philip-Hex screws (4 for each element bank)
 - Four Heater element cover mounting 3/8 Philip-Hex screws
 - Two electrical box mounting 3/8 Philip-Hex screws
 - Push in wire-ties
 - This installation manual



For technical assistance contact your local distributor or Bosch Technical Support:
1-866-642-3198 or
Bosch.Fhp.TechSupport@us.bosch.com.

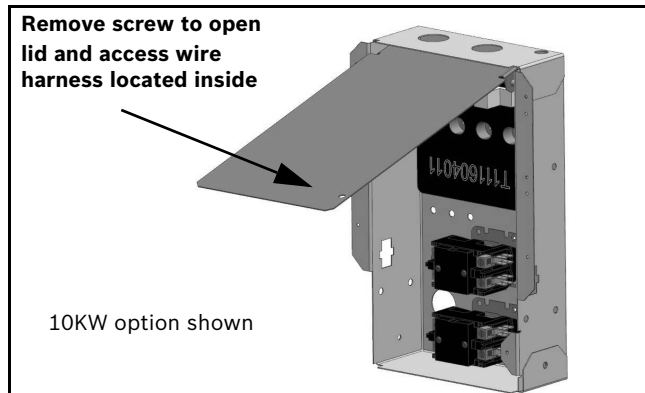

Figure # 1

Required Tools

- Phillips screwdriver
- Small flat head screwdriver
- 5/16" socket and a ratchet or drill
- Torque Phillips head screwdriver
- Multi meter
- Wire Stripper

ELECTRIC HEAT KIT

The Electric Heat field installed kit contains two main electrical enclosures: Electric Heat Control Box and Electric Heat Elements, both are located in the blower compartment. (Figure#2 through #5)

The control box attaches to the corner post and the heat elements to the blower heater collar in the blower compartment

- [1] Heating element cover
- [2] Electric Heat control box

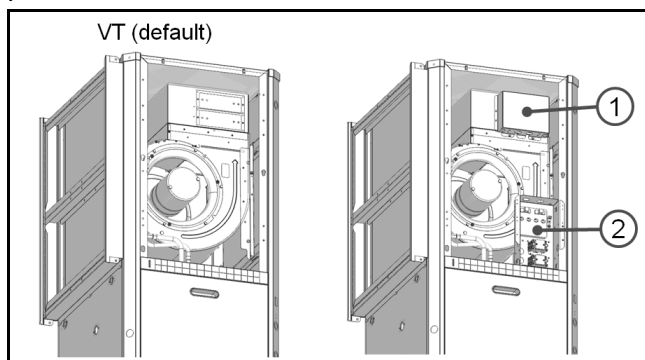

Figure # 2

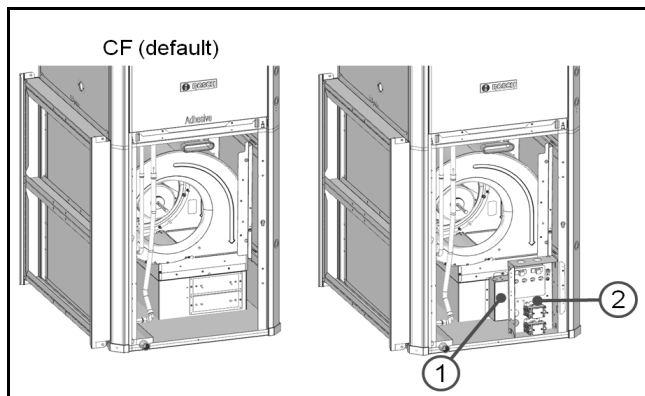

Figure # 3

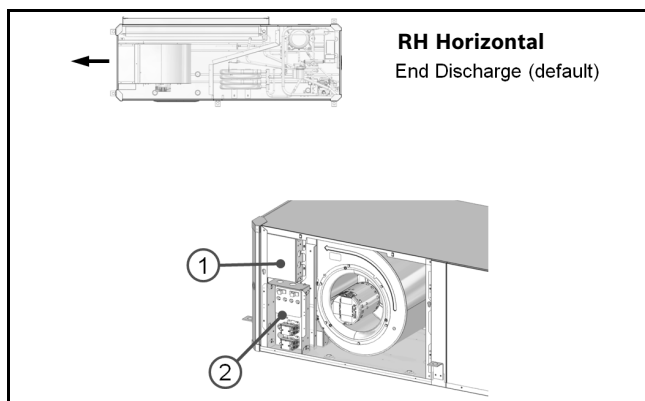

Figure # 4

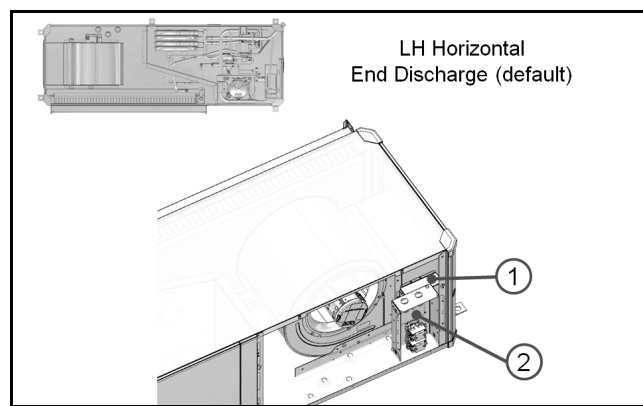

Figure # 5

INSTALLATION - HARDWARE

1. At Thermostat Turn system to "OFF"
2. Turn the main power to the heat pump to "OFF" at the unit's disconnect switch or breaker panel.



DANGER: Follow appropriate lockout/tag out procedure.

3. For units with display, prior to removing the blower panel, disconnect unit display from the back of the panel.(Figure#6)

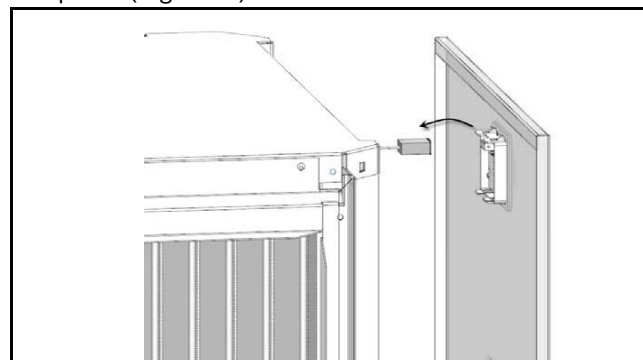

Figure # 6



In some models you may have to remove top and bottom panels to access both the heater collar and the electric box.

4. Remove the access panel(s) from the unit exposing the blower section and compressor section of the packaged heat pump unit.
5. Install Electric Heat Control Box as shown in Figures#2 to 5 based on your unit configuration.



Orient the heater control box with contactor (s) towards the bottom.



Pictures are for reference purposes only, no actual units on pictures but location of EHK is the same.

6. Remove the heater collar cover plate(s). (Figure#7)

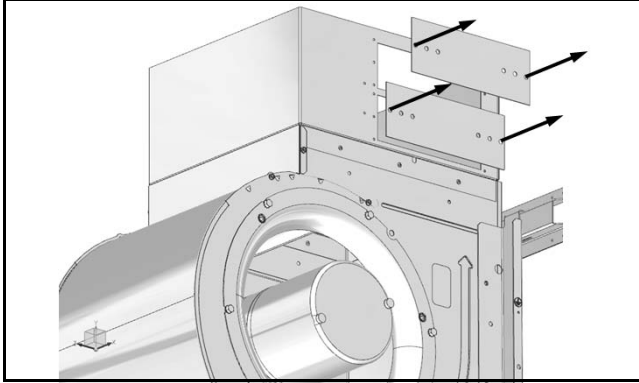

Figure # 7

7. In preparation for heater element installation orient, the heating elements with thermal overloads (cutouts) as shown in Figure # 8. This will ensure the heater elements are exposed to airflow.

NOTICE: Appropriate Thermal Overloads (cutouts) orientation is required for safe unit operation.

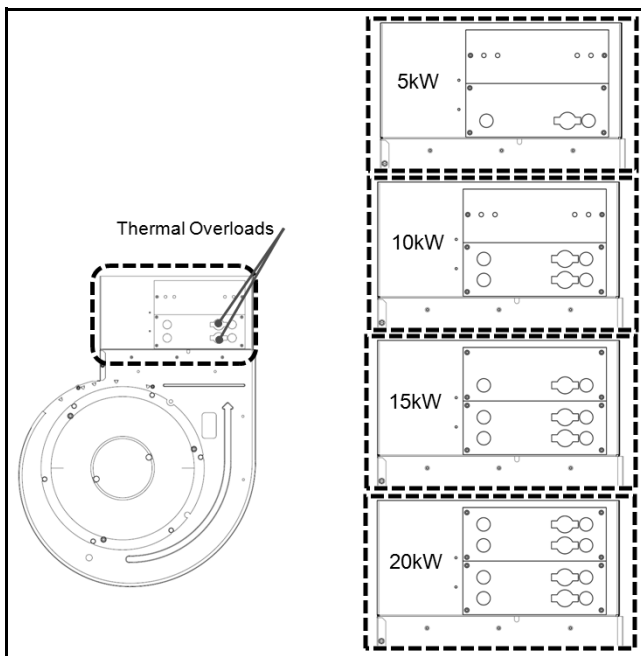

Figure # 8

8. Insert heating element(s) into collar. Heating element rods must be inserted into inner most holes as shown in Figure#10. This will support and prevent vibration of heater elements.



Based on the blower outlet size, some units may come from the factory with an additional extension bracket, installed on the inside of the cover plate. Heating element rods must be aligned to extension brackets accordingly.(see figures# 9 & 10)



Figure # 9

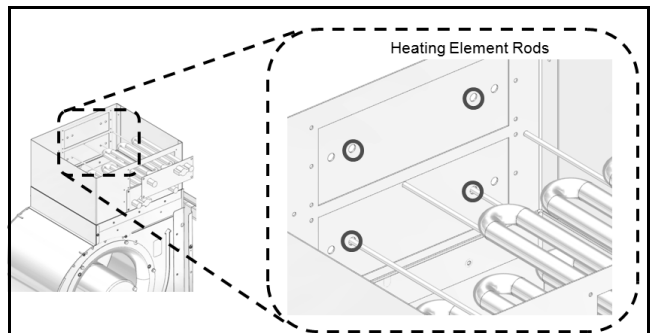

Figure # 10



If only one heating element is being installed, install it into the position closest to the blower wheel. Remaining opening to be covered using (1) of the cover plates removed in step 6.

9. Secure each insert(s) with four of the supplied sheet metal screws (Figure#11).

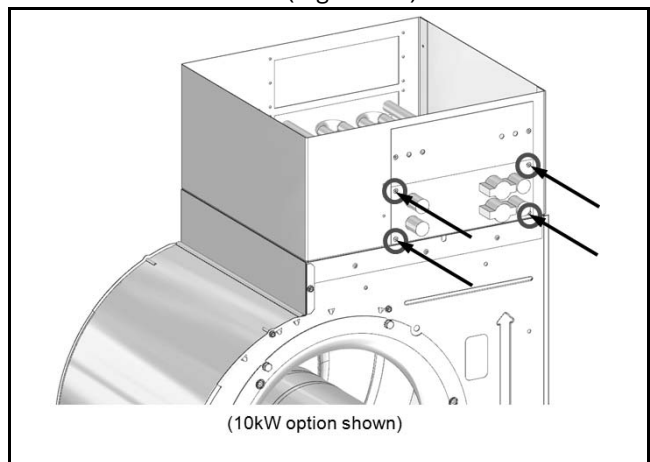

Figure # 11

INSTALLATION - WIRING

There are three Electric Heater control box layouts depending on HK model. (Figures#12, #13 and#14)

i HR1 controls Heating Elements 1 and 3 and HR2 controls heating elements 2 and 4.

i Refer to wiring diagram on Page# 12 to 16

i Electric Heater control box is completely pre-wired from the factory.

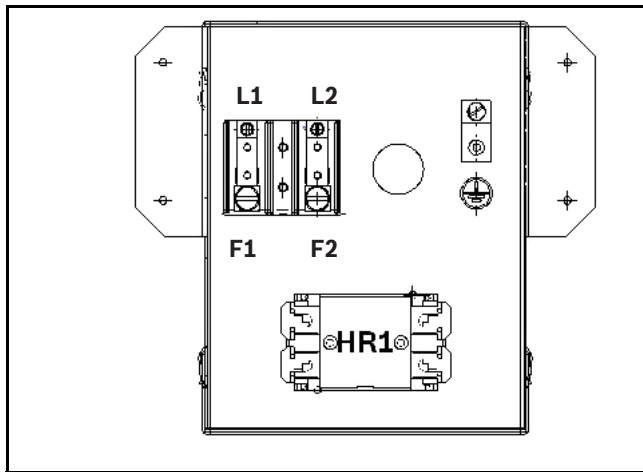

Figure # 12 5kW

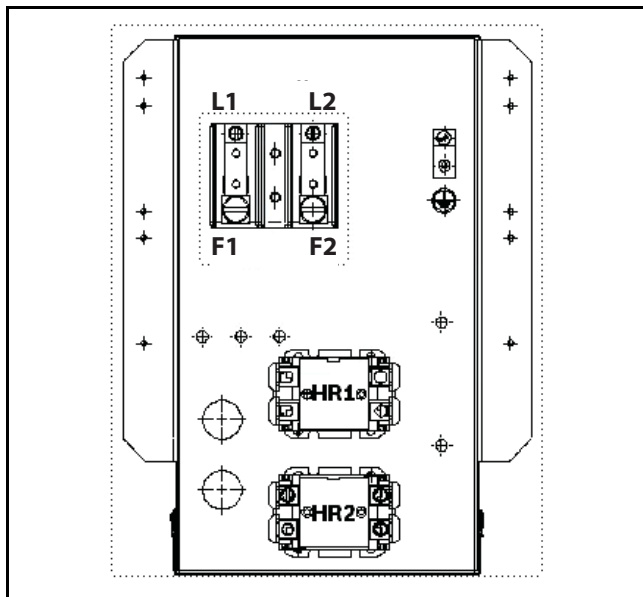

Figure # 13 10kW

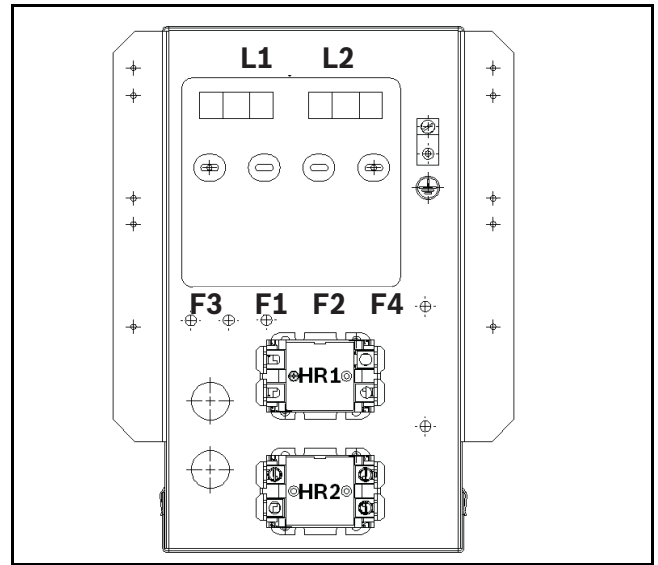

Figure # 14 15kW-20kW

1. Ensure high voltage Red and Black wires, are routed originating from the Electric Heater control box through grommets in the Electric Heater Element cover as show in Figure#15.

NOTICE: Make sure that the plastic grommets are used to prevent wire rubbing damage.

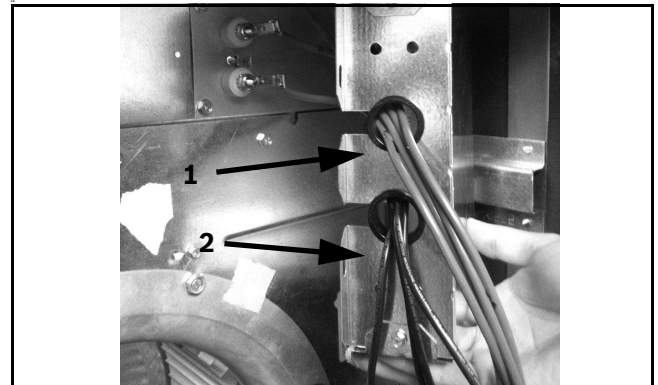

Figure # 15

- [1] Red wire
- [2] Black wire

NOTICE: Ensure that no wires are pinched between the metal parts

2. Ensure red and black high voltage wires originating from Electric Heater control box to the Electric Heater elements are routed as shown in Figure#16. (Black wires labeled HLS at the thermal limits cutouts and Red wires labeled HT at the heater element connections.)



Each wire is labeled for ease of identification. Reference wiring diagram on Page # 12 to 16

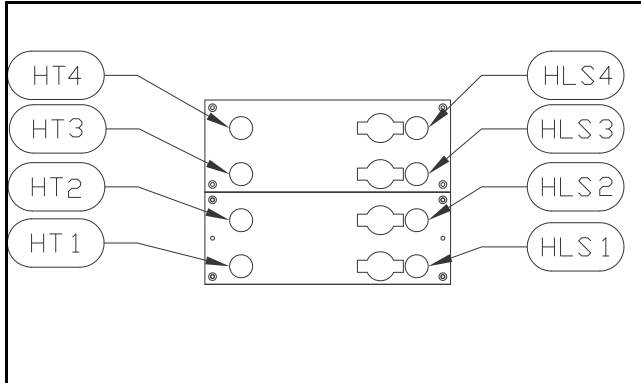

Figure # 16

3. Remove (2) screws as shown. (Figure#17)

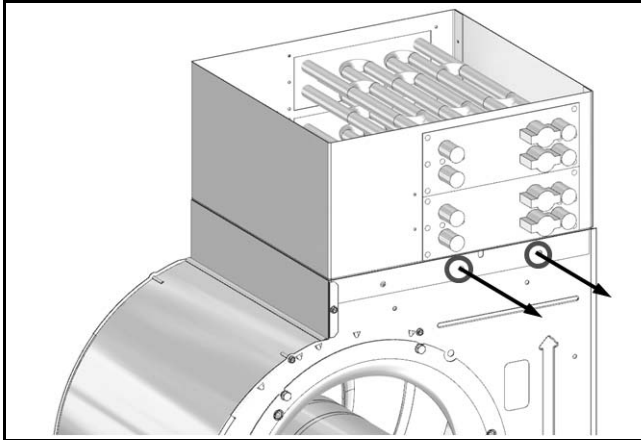

Figure # 17



Some models will have screws on the side of the heater element cover instead of the bottom.

4. Mount Heater Element cover to blower collar using (4) 3/8 Philip-Hex screws. (Figure#18)

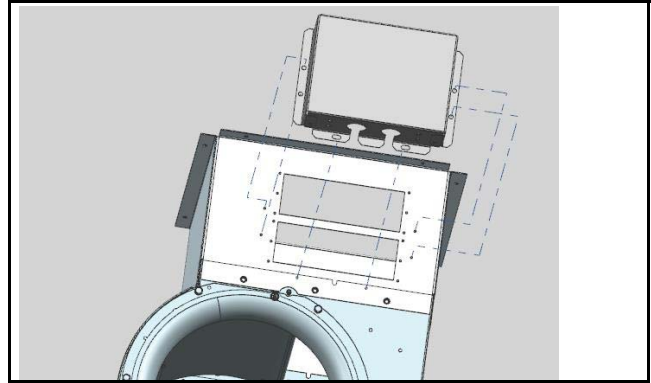

Figure # 18

5. Install the cover for the control box with the provided screws.
6. Remove and retain cork tape covering the hole in the divider panel.
7. On the wiring harness supplied with this kit identify J39 plug. (Figure#19)

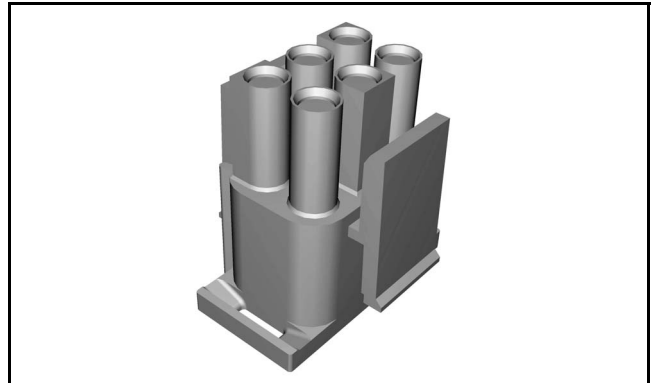

Figure # 19

8. Route J39 plug from condensing section through the hole in the divider panel and mate the plug to the receiving connector P39 on the side of the electric heat control box in the air handling section.
9. Re-apply cork tape to the divider panel hole.



The control box is designed to allow the P39 connector to be relocated in the field to the opposite side of the control box for right-return air configuration

10. Route the other end of the harness that remains in the condensing section(4 connector end) along the already installed blower harness, and terminate it at the unit electrical box (E-Box). Use tie-wraps every 12-18 inches for a neater finish.



The screws attaching the electrical box may need to be removed for the easier installation of wiring.

11. In the heat pump electrical box, disconnect the J19/P19 high voltage wires that connect the blower motor to the "line voltage" these wires are located on the bottom left below contactor.(Figure#20)



Figure # 20

12. Mate J19 plug originating from the electric heat control box (red and black wires) with P19 plug originating from blower harness at E-Box.



When mating plugs, push both connectors together until they snap with a click.

13. Disconnect the red and black line voltage harness (8733901778) from the transformer primary side and the contactor line side, and remove the harness from the E-box entirely.)
14. Locate the two line voltage red and black wires that derived from the P19 plug, and connect T1 COM to the transformer COM and connect the T1 VLT to the transformer 240v or 208v per the desired primary voltage tap.
15. There will be one harness (black and white wires) left connected to the compressor contactor. Remove and discard this loose harness from the contactor.
16. There should now be one plug left labeled P12 on the electric heat harness you may follow one of these steps based on your unit model revision:
 - (a) Mate this plug to its counterpart plug already available on the left hand side of the e-box labeled J12.
 - (b) Mate this plug to Harness 8733811804 provided with EH kit, and connect the three loose wires (W1,W2 and C) to Thermostat Terminal Block or ECM board to corresponding terminals W1, W2,C.



Ensure heater element wires are routed through the plastic grommets available in the kit, and perform a continuity test to ensure all connections are secure.



WARNING: When routing wiring avoid sharp edges as these can chafe wiring insulation, exposing the conductor. This can result in equipment damage and personal injury.

ELECTRIC HEAT ELECTRICAL DATA

	Circuit Branches		Fan Motor		MCA 208V / 240V	MOCP 208V / 240V	Heater Element	
			HP	FLA			kW 208V / 240V	A 208V / 240V
HK050-1201	5kW Single Circuit		0.33	2.8	25.1 / 28.5	30 / 30	3.6 / 4.8	17.3 / 20
			0.5	4.1-4.3	27 / 30.4	30 / 35		
			0.75	6	29.1 / 32.5	35 / 35		
			0.75-1.0	6.8-7.6	31.1 / 34.5	35 / 40		
			1.0	9.1	33 / 36.4	40 / 45		
HK100-1201	10kW Single Circuit		0.33-0.5	2.8-4.3	48.6 / 55.4	50 / 60	7.2 / 9.6	34.6 / 40
			0.75-1.0	6.0 -7.6	52.8 / 59.5	60 / 60		
			1.0	9.1	54.6 / 61.4	60 / 70		
HK150-1201	15kW Single Circuit		0.75-1.0	6.0-9.1	76.3 / 86.4	80 / 90	10.8 / 14.4	51.9 / 60
	15kW Dual Circuit	Ckt 1 +	0.75-1.0	6.0-7.6	52.8 / 59.5	60 / 60	7.2 / 9.6	34.6 / 40
			1.0	9.1	54.6 / 61.4	60 / 70		
		Ckt 2	-	-	21.6/ 25	25 / 30	3.6 / 4.8	17.3 / 20
HK200-1201	20kW Single Circuit		0.75-1.0	6-9.1	97.9 / 111.4	100 / 125	14.4/19.2	69.2/80
	20kW Dual Circuit	Ckt 1 +	0.75-1.0	6-7.6	52.8 / 59.5	60 / 60	7.2 / 9.6	34.6 / 40
			1.0	9.1	54.6 / 61.4	60 / 70		
		Ckt 2	-	-	43.3 / 50	50 / 60	7.2 / 9.6	34.6 / 40

Table # 1



Match the blower motor HP and FLA from unit data plate and determine appropriate MCA and MOCP as per table below.

+ for dual circuits

Ckt 1 includes blower motor FLA for calculation of MCA and MOCP.

THERMOSTAT WIRE CONNECTIONS

1. Assure that two low voltage wires are available from the thermostat to make the “W1” and “W2” connections. If these wires are not located, they will need to be pulled and routed from the back of the thermostat to main thermostat connections on the electrical box or to the motor control board.
2. Strip the insulation off of the “W1” and “W2” wires and insert into the thermostat control wire block or on the motor control board thermostat interface. Connect the other end of the wires to the back of the thermostat to the supplemental and emergency heat terminals.

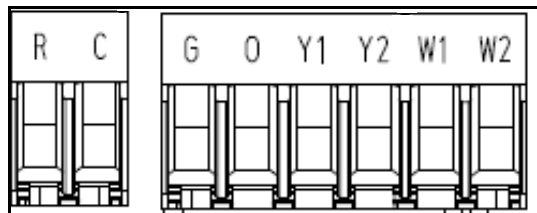

Reference the Thermostat User Manual for Low voltage wiring.

Field Line Voltage Connection

Circuit Breaker Panel To Heater

Electrical Box

1. Select the appropriate wire size based upon the heater electrical load that the blower motor and electric heater element(s) will require. Refer to the data tag label that is included in the heater kit or the Electric Heat Electrical Data table#1 of this manual. Ensure that all national and local electrical codes are followed for installation, wire sizing, and breaker sizing.
2. Select the appropriate breaker size based upon the heater electrical load that the heat pump will require. Refer to the data tag label that is included in the heater kit or the Electric Data(table#1) of this manual.
3. Route the new line voltage wiring and the ground wire from the circuit breaker panel to the heat pump.
4. Use the knockout provided in the heat pump corner post as the entry for the electrical service wiring. A plastic grommets should be used to protect the wire insulation from the metal edge of the knockout
5. Connect one of the line voltage wires to "L1" terminal connection and the other line voltage wire to "L2" terminal connection. Torque to 22 in-lbs.
6. Use the ground lug provided in the heater control box to connect the field ground from the power supply.

Wiring Diagram Replacement/Data Plate Placement

1. Remove the wiring diagram that is adhered to the back side of the front panel. Replace with the wiring diagrams included with the Heater Kit as per Table #2 based on your unit model:

Unit Model	Replace with Diagrams P/Ns
SM/CE EON MOTOR	8733813521 + 8733813478
BP EON MOTOR	8733813521 + 8733809183
BP X13 MOTOR	8733813521 + 8733809181

Table # 2

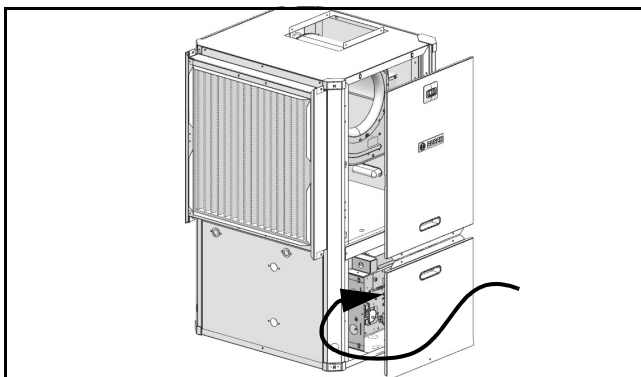

Figure # 21

Place the adhesive backed heater data label above existing data plate label.

Unit Start Up

1. Turn the disconnect switch or breaker switch to the "ON" position for the compressor and for the new separate circuit servicing the blower motor and the heating elements.
2. Run the unit in heating mode with the heating elements engaged for at least 10 minutes to ensure the unit does not shut down due to any temperature limiting device.

INFORMATION ON DECOMMISSIONING

Only trained and qualified technicians are allowed to decommission and dispose of equipment following applicable requirements and local codes.



WARNING: Decommissioning of this equipment can be hazardous due to system pressure and electrical components. Only trained and qualified personnel should install, repair, or service the equipment.

Protecting the Environment

Components

Many parts in the Heat Pump can be fully recycled in the end of the product life. Contact your city authorities for information about the disposal of recyclable products.

Refrigerant

At the end of the service life of this appliance and prior to it's environmental disposal, a person qualified to work with refrigerant circuits must recover the refrigerant from within the sealed system.



By disposing of this product correctly you will help ensure that the waste undergoes the necessary treatment, recovery and recycling-thus preventing potential negative effects on the environment and human health which could otherwise arise due to inappropriate waste handling.

WIRING DIAGRAMS

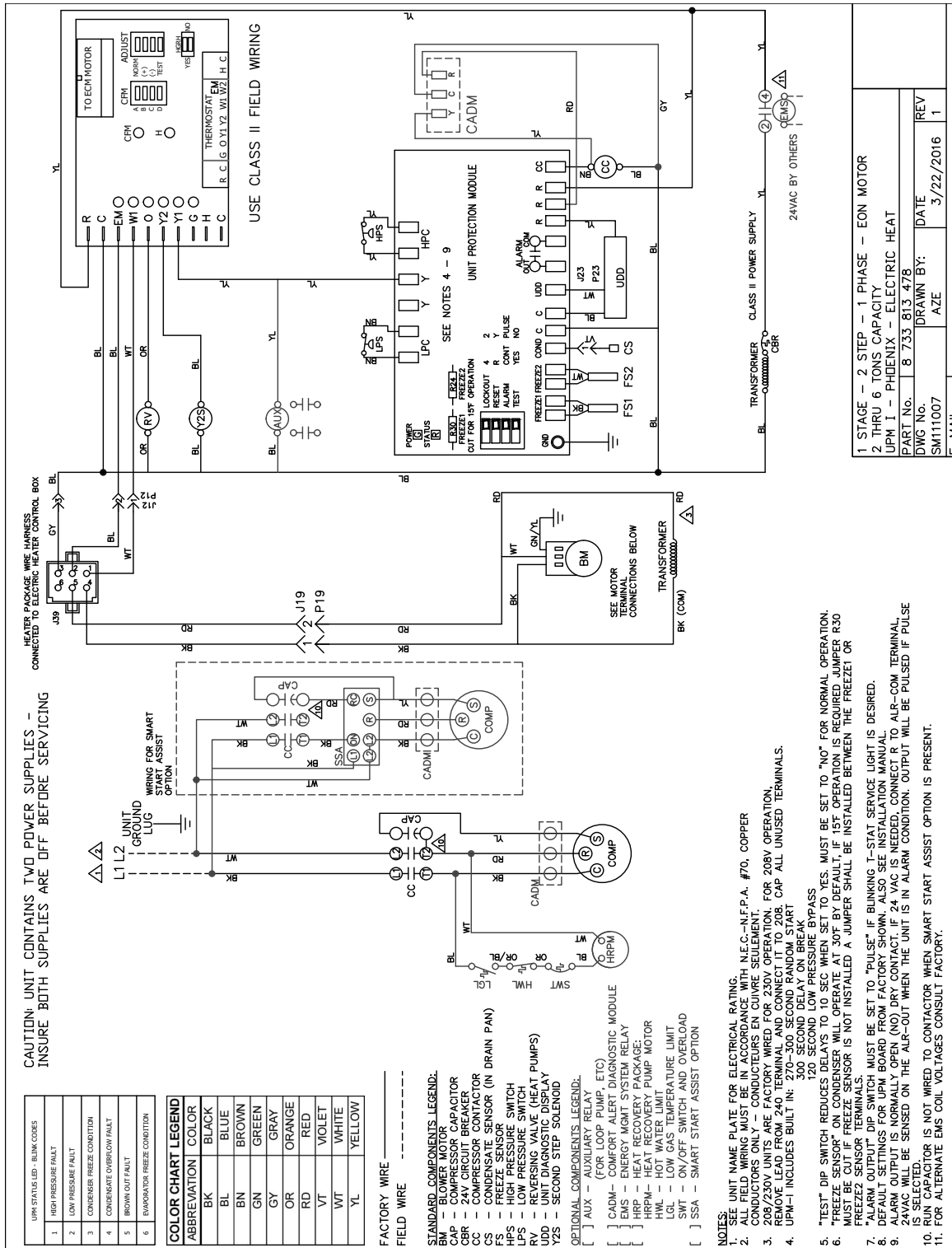

Figure # 22



Actual unit wiring may vary from this example. Always refer to the wiring diagram attached to the unit.

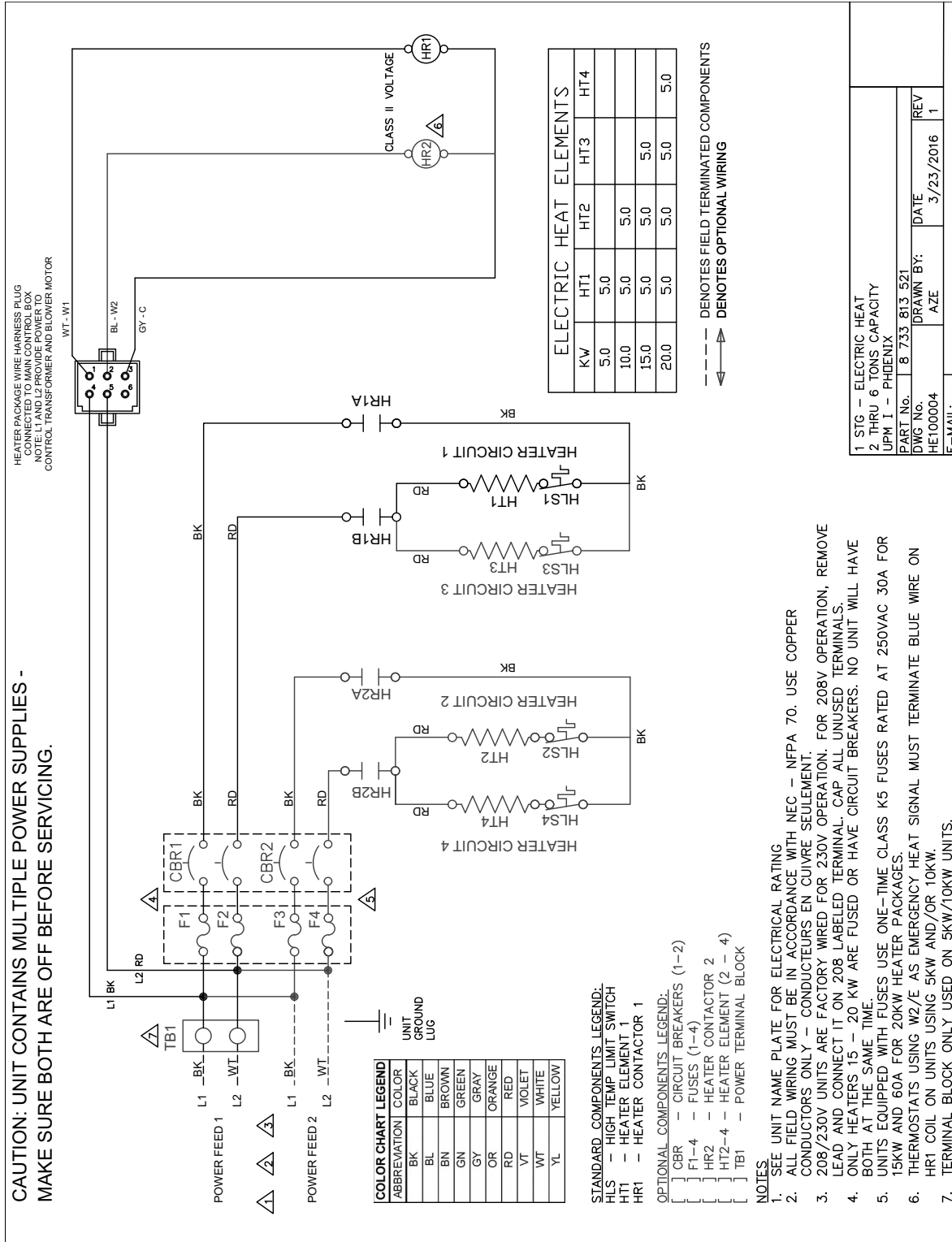

Figure # 23



Actual unit wiring may vary from this example. Always refer to the wiring diagram attached to the unit.

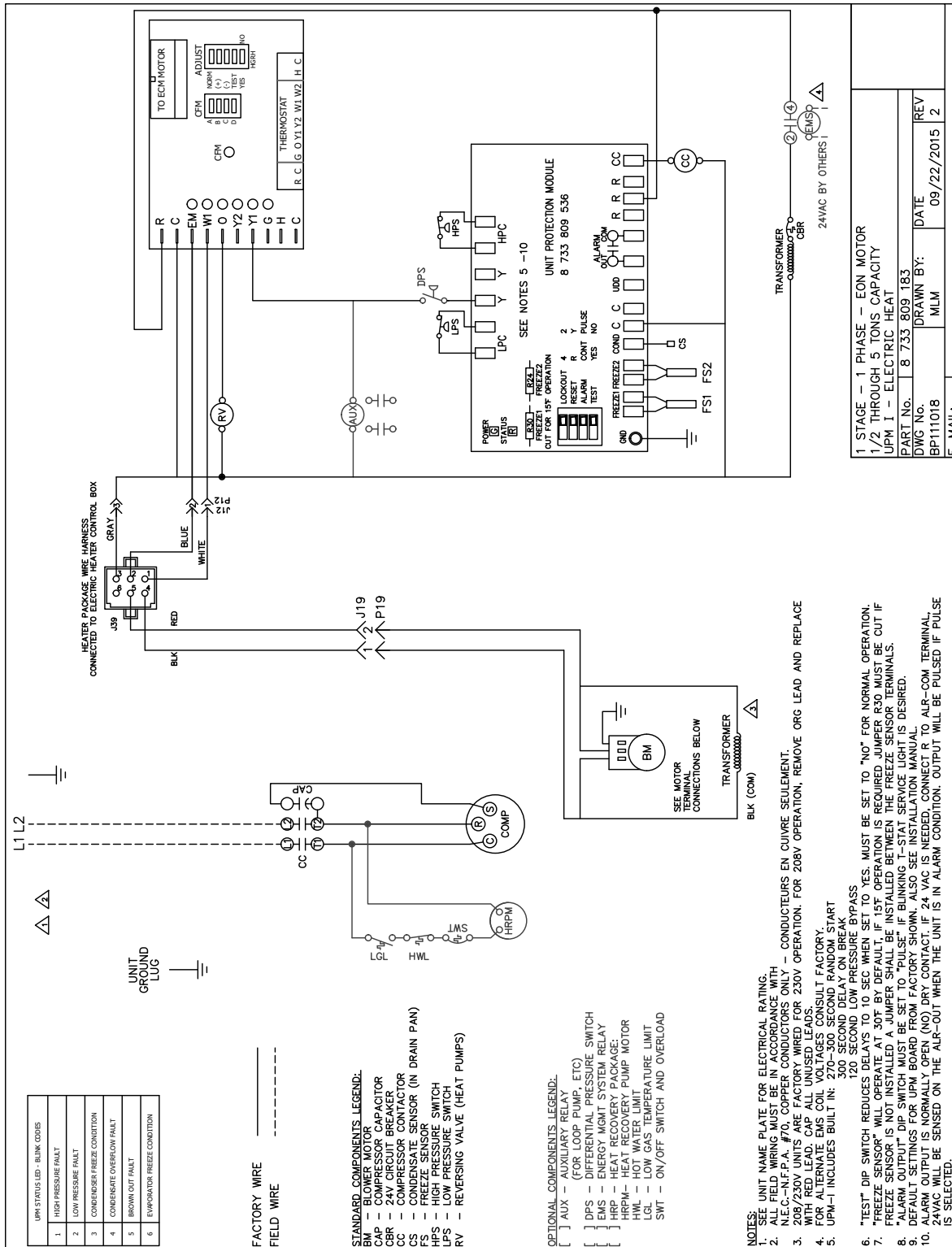

Figure # 24



Actual unit wiring may vary from this example. Always refer to the wiring diagram attached to the unit.

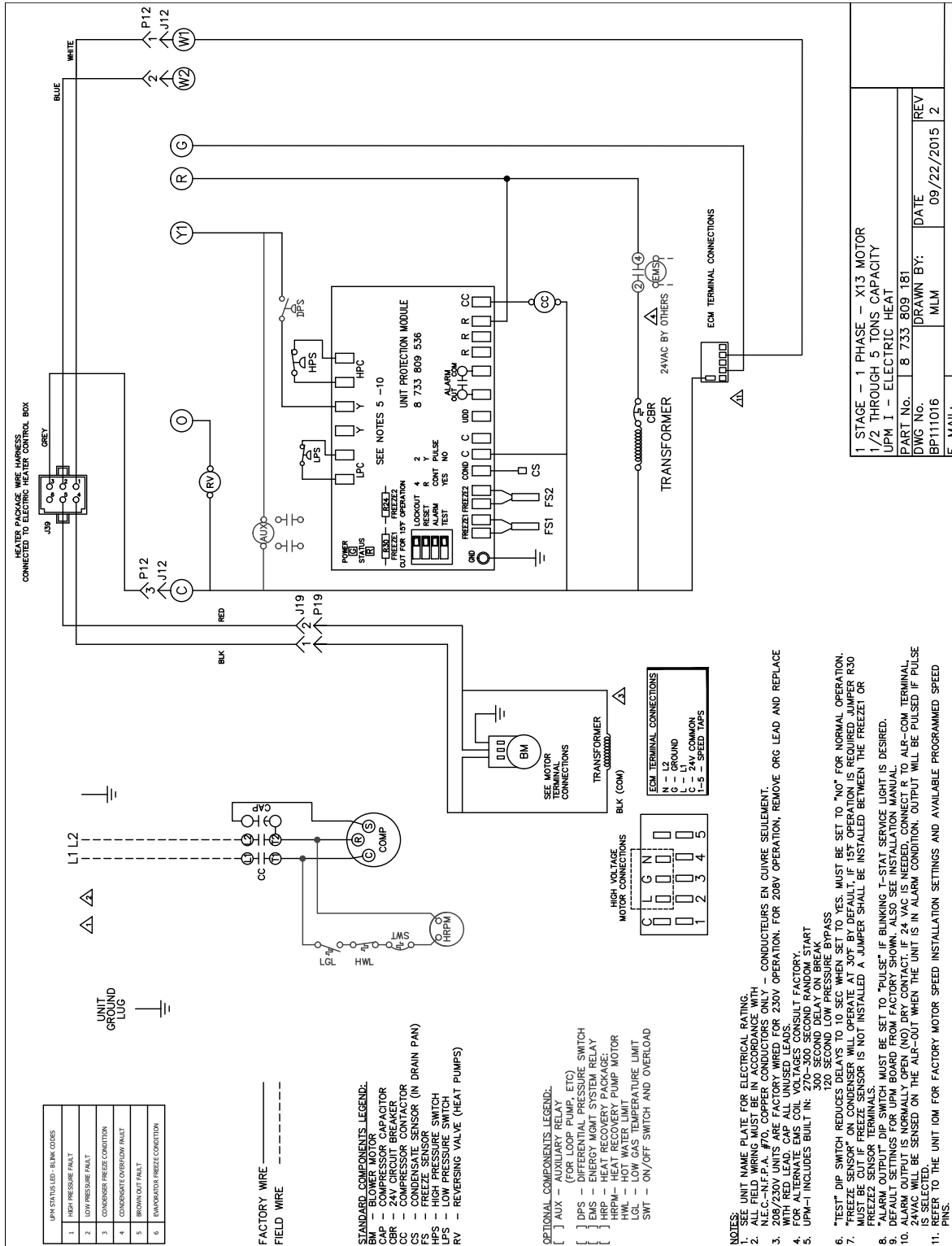

Figure # 25



Actual unit wiring may vary from this example. Always refer to the wiring diagram attached to the unit.

EBOX LAYOUTS

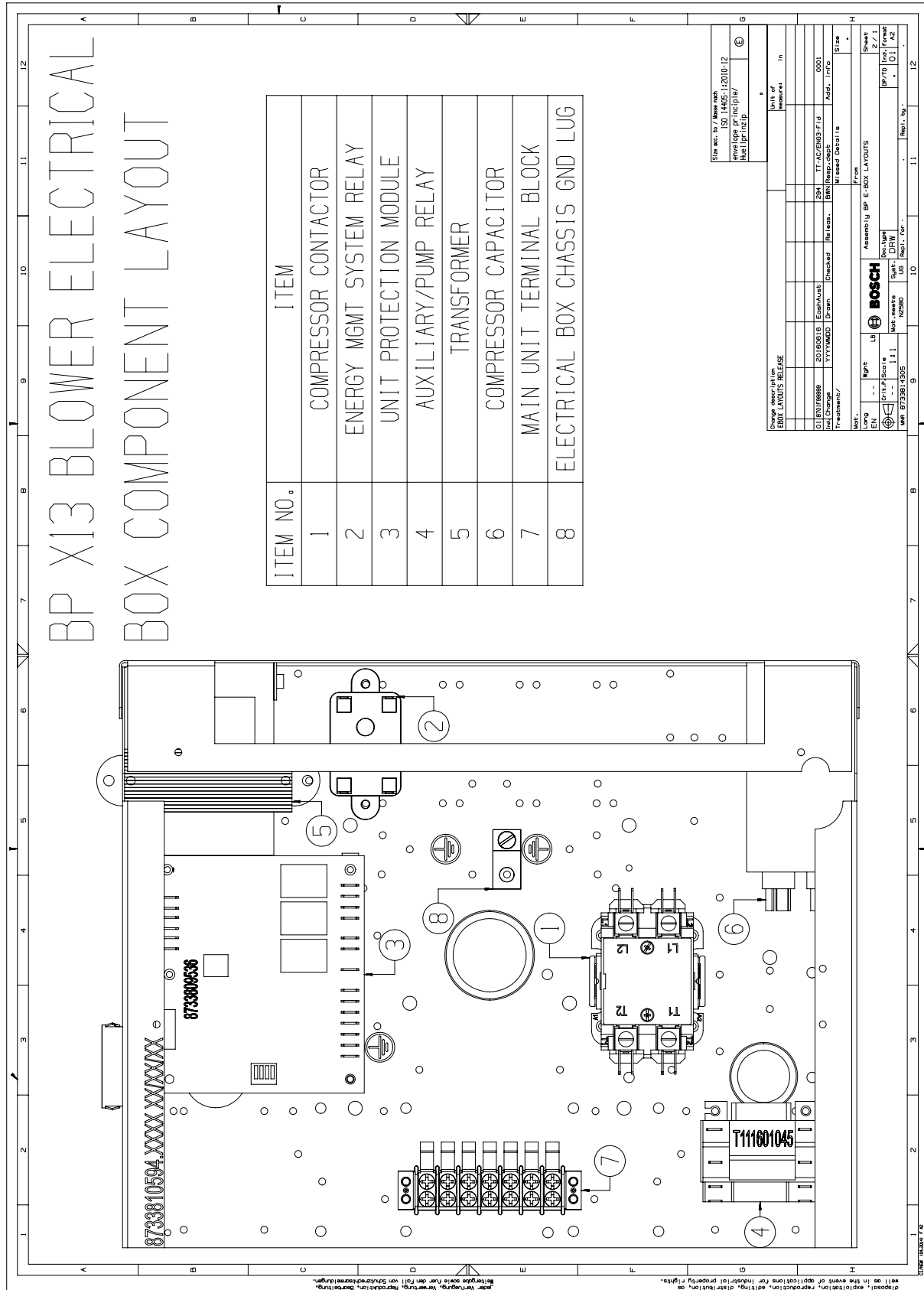

Figure # 26

SM Rev A

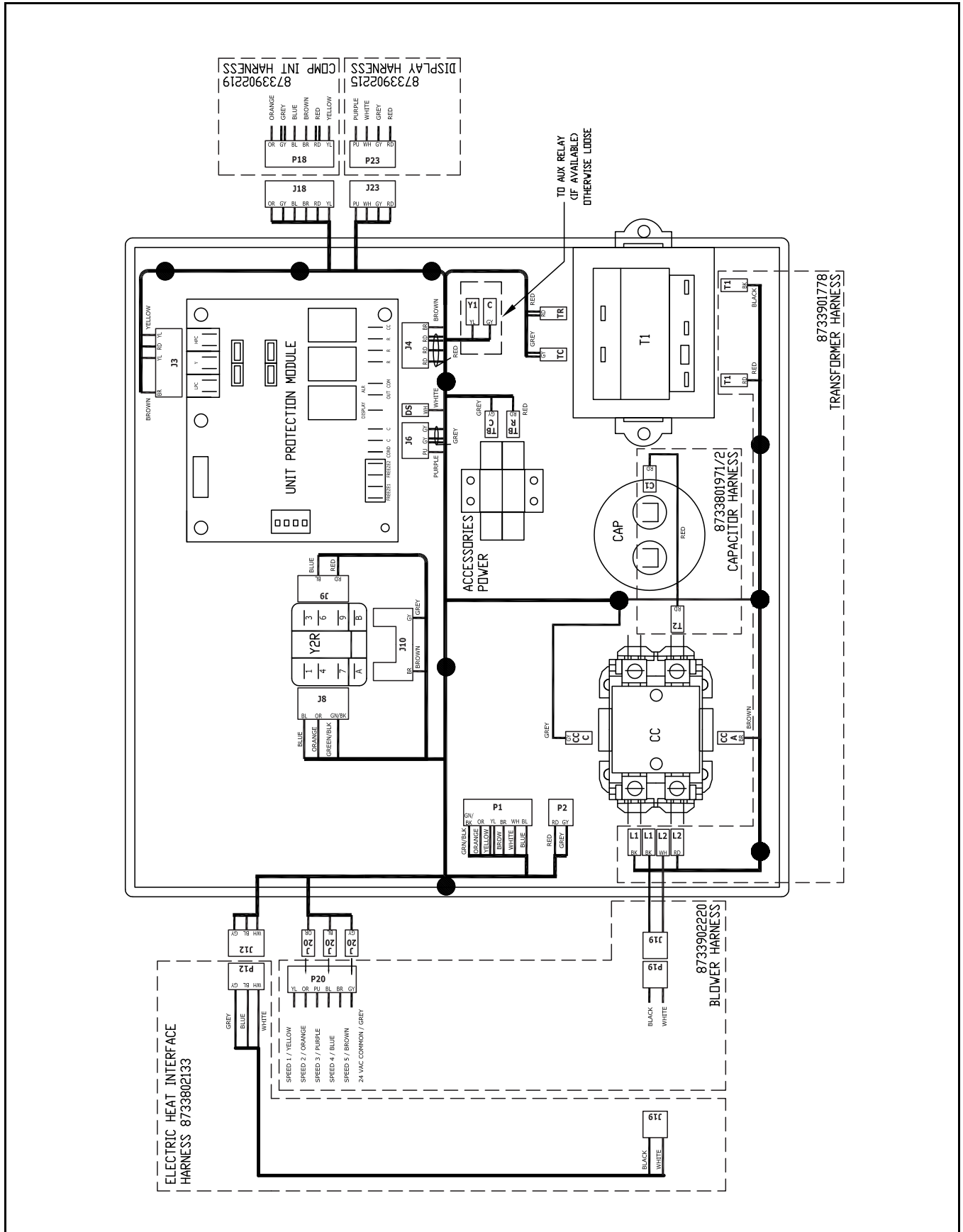

Figure # 27

SM Rev B

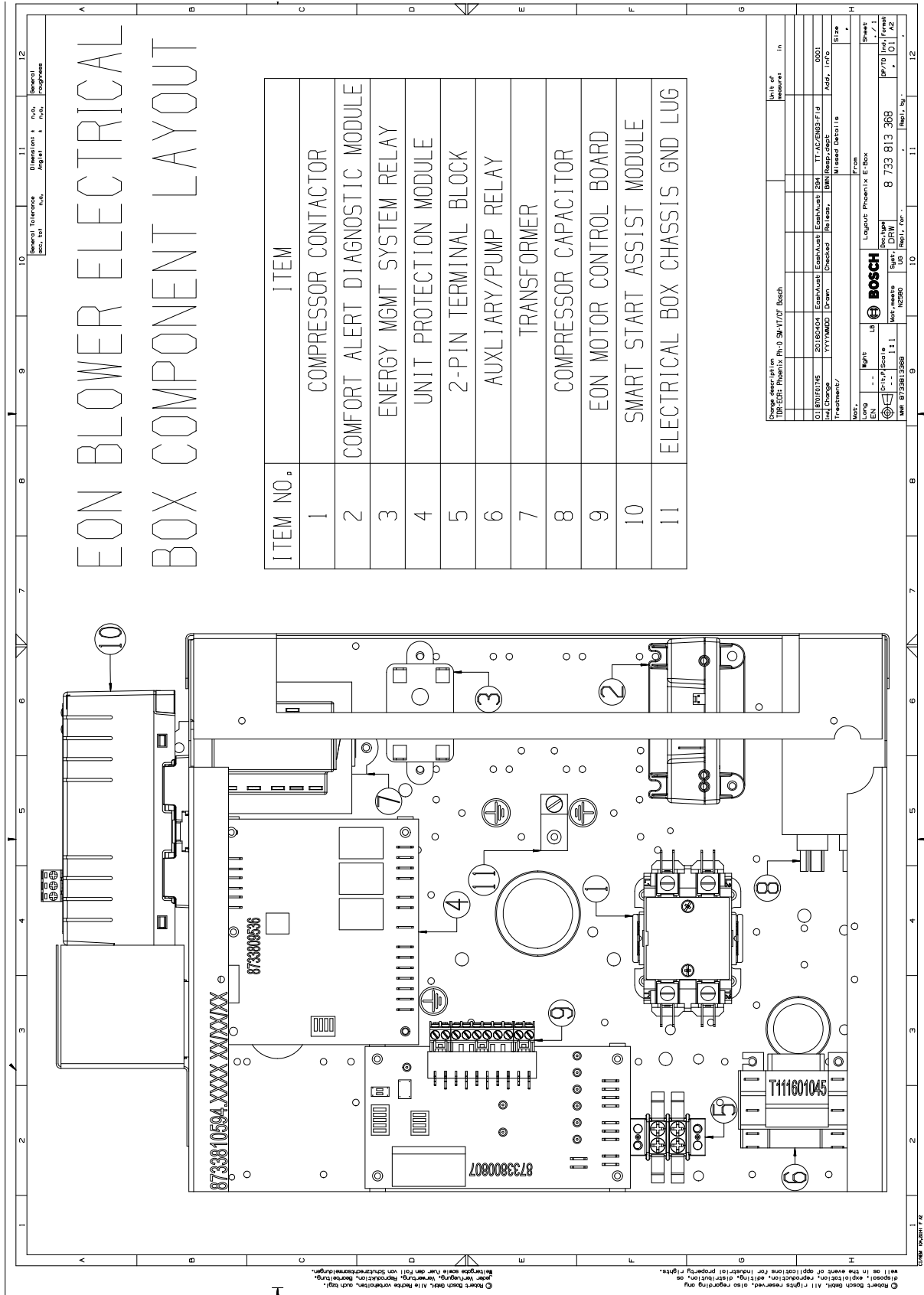

Figure # 28

NOTES



BOSCH

555 N.W. 65th Court, Ft. Lauderdale, FL 33309
Phone: 866-642-3198 | Fax: 954-776-5529
www.bosch-climate.us
(2016/07)



Intertek