



325 COMMERCE DRIVE
 MT VERNON, OH 43050
 800-253-8236

SPECIFICATION DATA SHEET

DATE: 8-6-13
 PREPARED BY: RL

**MODEL NO. 9150
 PVC SPIRAL ELBOW**

STANDARD MODEL

DIMENSIONS

SIZE	A	B	C	D	SWEEP RATIO
4"	4"	4"	4"	8"	1.00
5"	5"	4"	4 1/2"	9"	0.90
6"	6"	4"	5"	10"	0.83
7"	7"	4"	5 1/2"	11"	0.78
8"	8"	4"	6"	12"	0.75
9"	9"	4 1/2"	7"	13 1/2"	0.78
10"	10"	5"	8"	15"	0.80
12"	12"	5 1/4"	9 1/4"	17 1/4"	0.77
14"	14"	5 1/2"	10 1/2"	19 1/2"	0.75
16"	16"	5 1/4"	11 1/4"	21 1/4"	0.70
18"	18"	4 1/2"	11 1/2"	22 1/2"	0.64
20"	20"	4 1/2"	12 1/2"	24 1/2"	0.63
22"	22"	4 1/4"	13 1/4"	26 1/4"	0.60
24"	24"	4 1/4"	14 1/4"	28 1/4"	0.59

MATERIAL SPECIFICATIONS

HOT DIPPED GALVANIZED STEEL.
 WITH A 4 MIL. POLYVINYL COATING
 ASSEMBLED WITH 1/8" STAINLESS STEEL RIVETS.
 4" - 8" = 26 GAUGE MINIMUM
 9" - 16" = 24 GAUGE MINIMUM
 18" & UP = 22 GAUGE MINIMUM
 CONSULT SMACNA DUCT CONSTRUCTION MANUAL
 FOR CORRECT GAUGE FOR YOUR APPLICATION.

OPTIONS

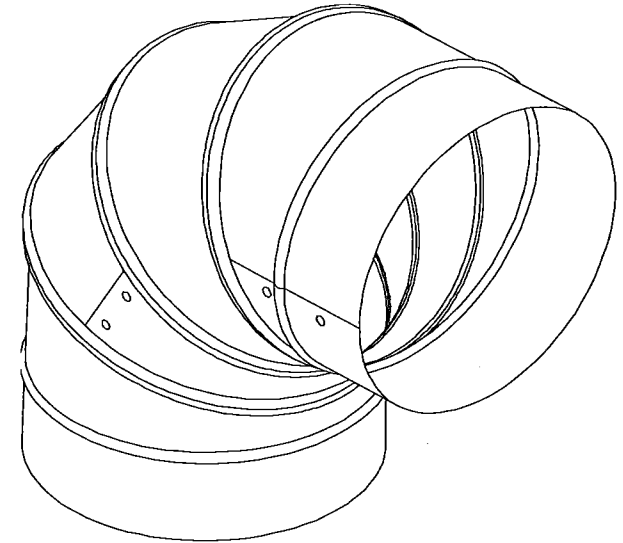
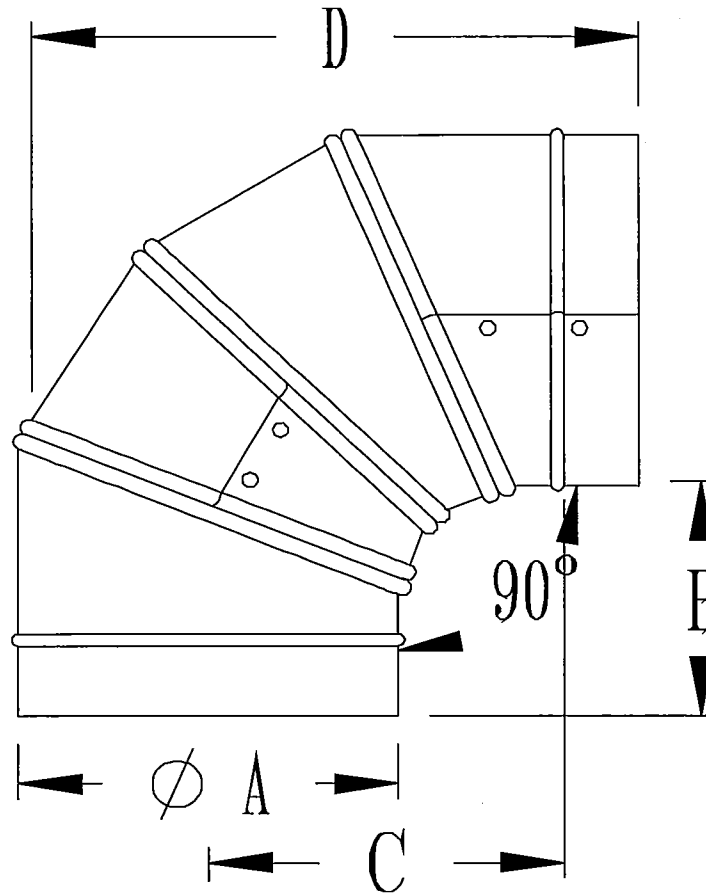

JOB: _____
 LOCATION: _____
 CONTRACTOR: _____
 ENGINEER: _____
 NOTES: _____