

C02 Sensor

Supplemental Wiring Manual for Accessories

EV-Series
SL-Series
EV Premium
HE-Series
LE-Series

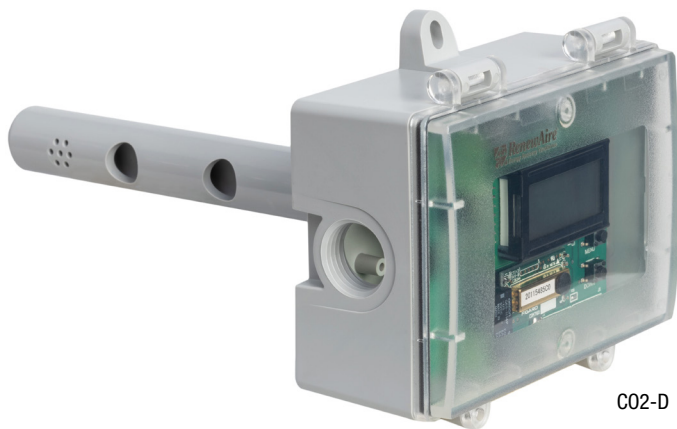

C02-D



C02-W

| | |
|-------------------------------|----------|
| 1.0 OVERVIEW | 3 |
| 2.0 DIMENSIONS | 3 |
| 2.1 C02-W | 3 |
| 2.2 C02-D | 3 |
| 3.0 ELECTRICAL | 4 |
| 3.1 WIRING SCHEMATICS..... | 4 |
| 4.0 FACTORY ASSISTANCE | 7 |

TABLE OF ILLUSTRATIONS

| | |
|--|---|
| Figure 3.1.0 Wiring Schematic for EV90, EV90P, EV130, EV200, EV240, EV300 Units Only | 4 |
| Figure 3.1.1 Wiring Schematic for EV Premium and SL75 Units | 4 |
| Figure 3.1.2 Wiring Schematic for HE1.5IN Units without ECM..... | 5 |
| Figure 3.1.3 Wiring Schematic for HE1.5RT, LE-Series, and all HE2X and Larger Units without VFDs or ECM | 5 |
| Figure 3.1.4 Wiring Schematic for HE-Series and LE-Series Units with Factory-Installed VFDs..... | 6 |
| Figure 3.1.5 Wiring Schematic for HE1.5 Units with ECM and Terminal Block..... | 6 |
| Figure 3.1.6 Wiring Schematic for HE07, HE10, and HE1.5 Units with ECM and Circuit Board | 7 |
| Figure 3.1.7 Wiring Schematic for HE07, HE10, and HE1.5 Units with ECM and Circuit Board and Timer..... | 7 |

1.0 OVERVIEW

The CO2 monitor uses a highly accurate and reliable Non-dispersive Infrared (NDIR) with state-of-the-art digital linearization and temperature compensated circuitry to detect CO2 levels in an attractive, low profile enclosure for room applications and a duct mount version. It provides a linear analog signal output of 4–20 mA, 0–5, or 0–10 VDC and a Normally Open (NO) relay to control an alarm or ventilation fan in various ways.

2.0 DIMENSIONS

2.1 C02-W

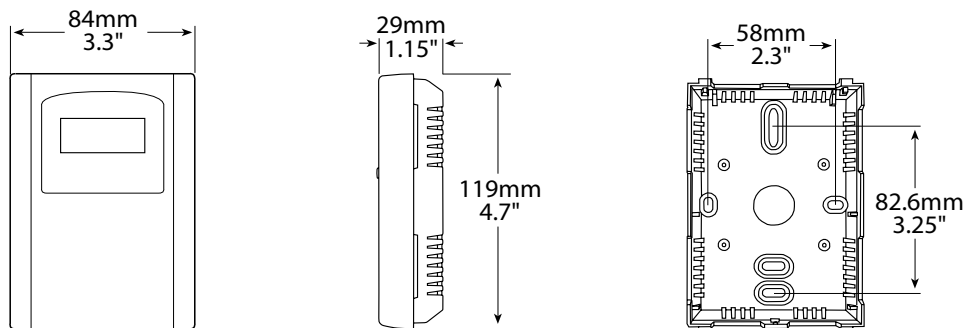

2.2 C02-D

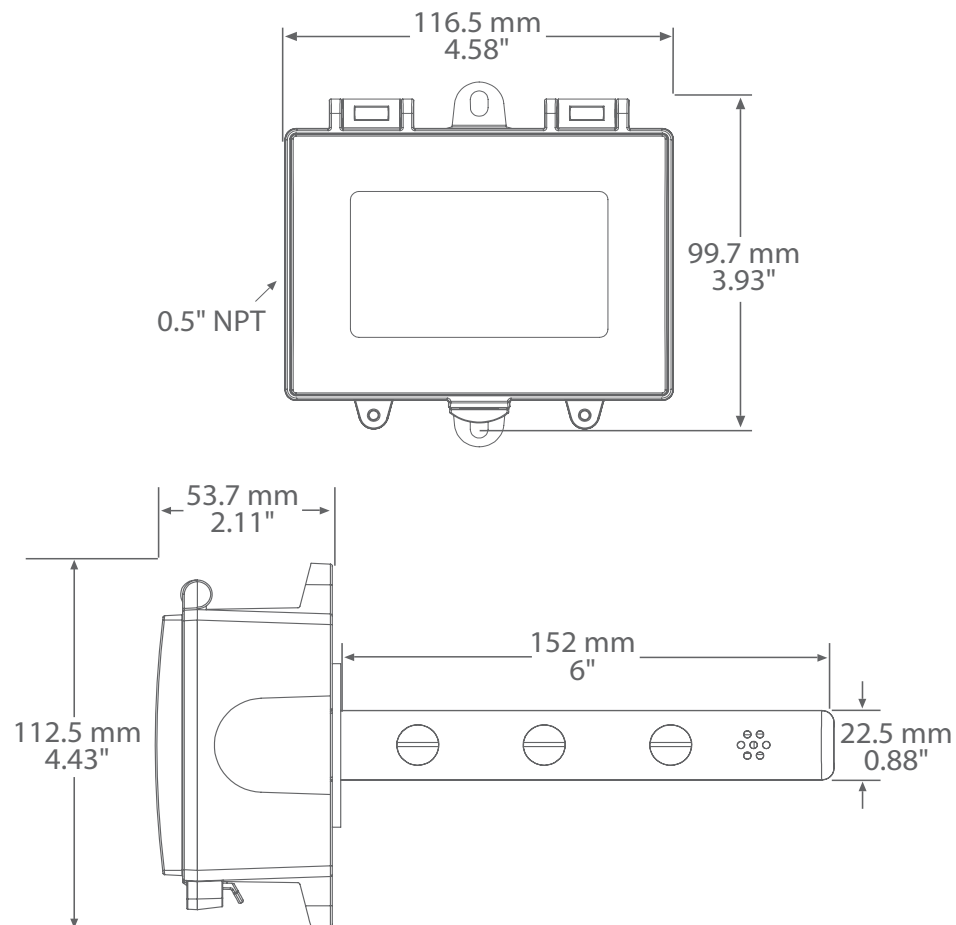

3.0 ELECTRICAL

3.1 WIRING SCHEMATICS

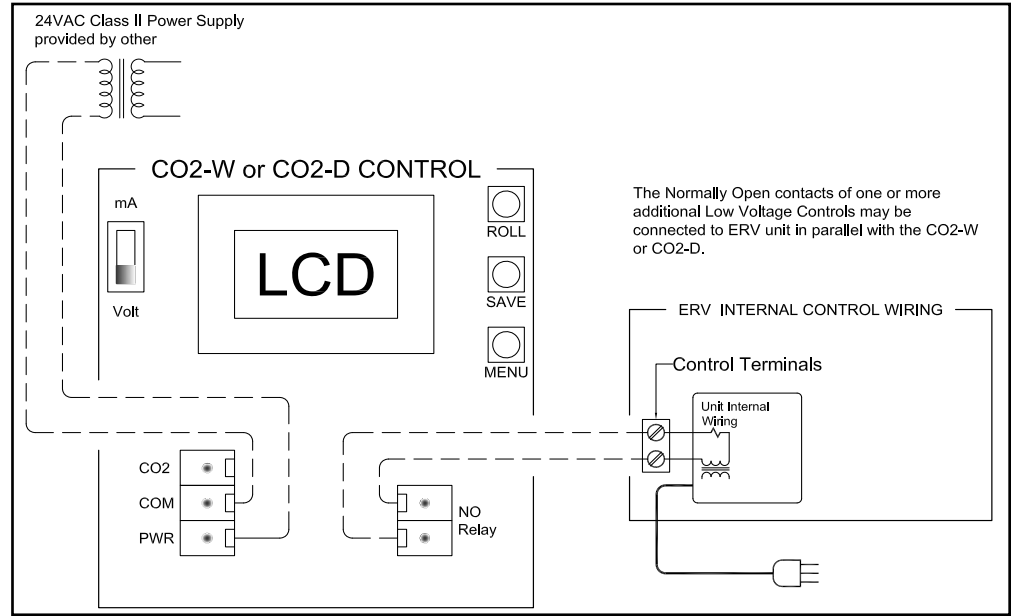

FIGURE 3.1.0 WIRING SCHEMATIC FOR EV90, EV90P, EV130, EV200, EV240, EV300 UNITS ONLY

In this example, CO2 Controller turns the Energy Recovery Ventilator (ERV) on at High speed when CO2 level exceeds CO2 Controller Relay setting.

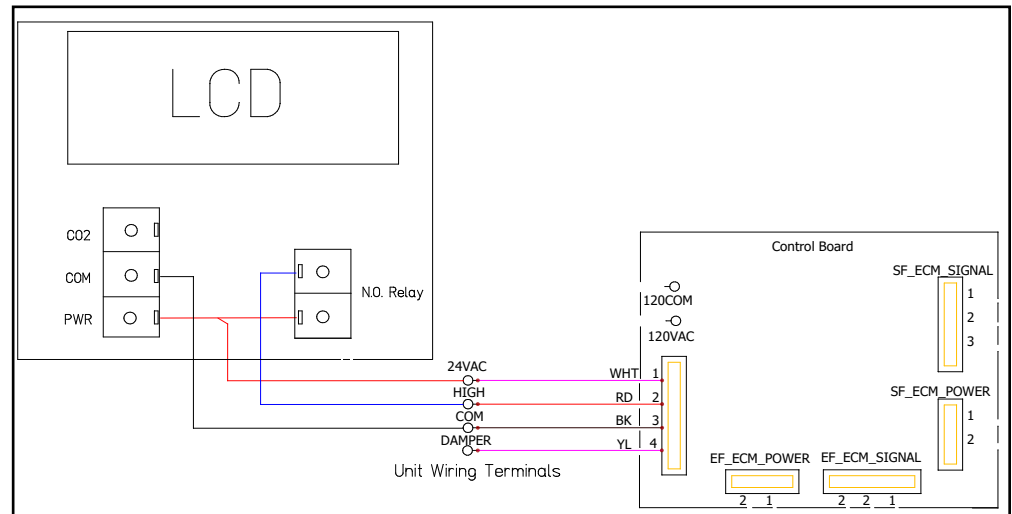

FIGURE 3.1.1 WIRING SCHEMATIC FOR EV PREMIUM AND SL75 UNITS

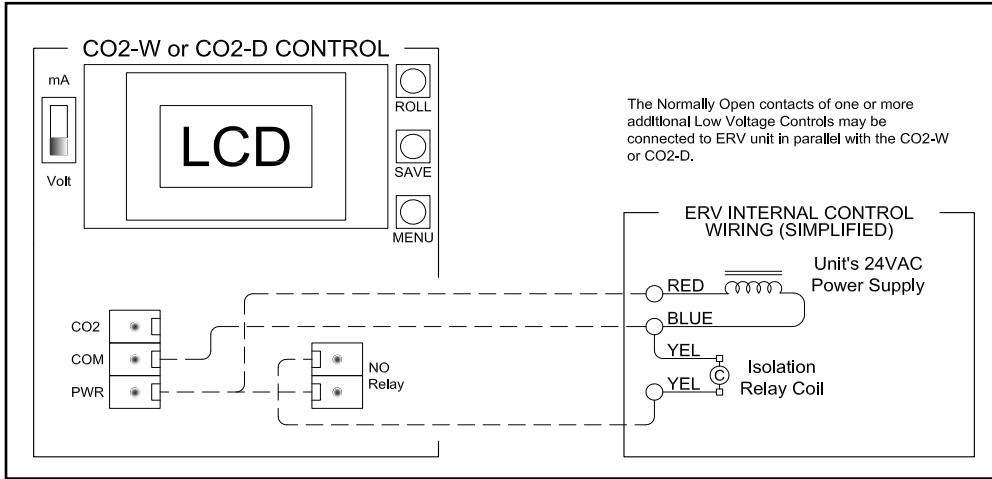

FIGURE 3.1.2 WIRING SCHEMATIC FOR HE1.5IN UNITS WITHOUT ECM

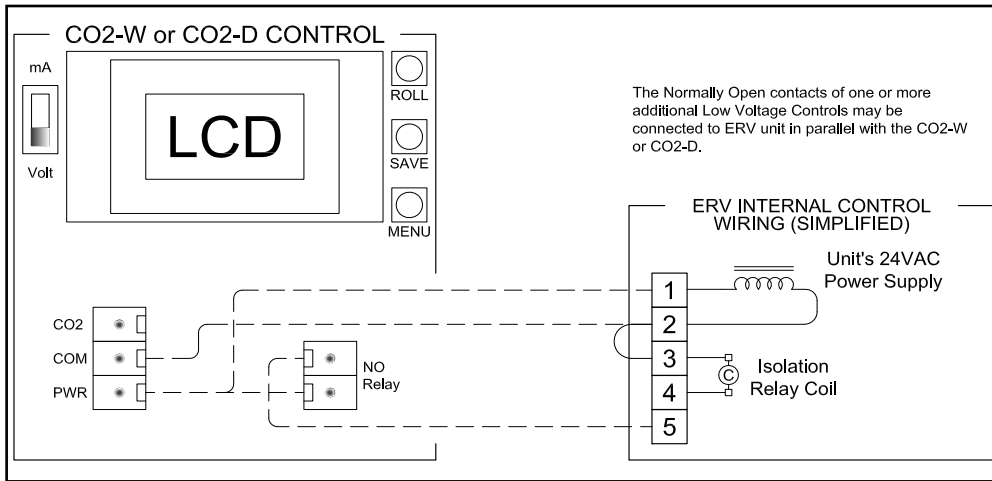

FIGURE 3.1.3 WIRING SCHEMATIC FOR HE1.5RT, LE-SERIES, AND ALL HE2X AND LARGER UNITS WITHOUT VFDS OR ECM

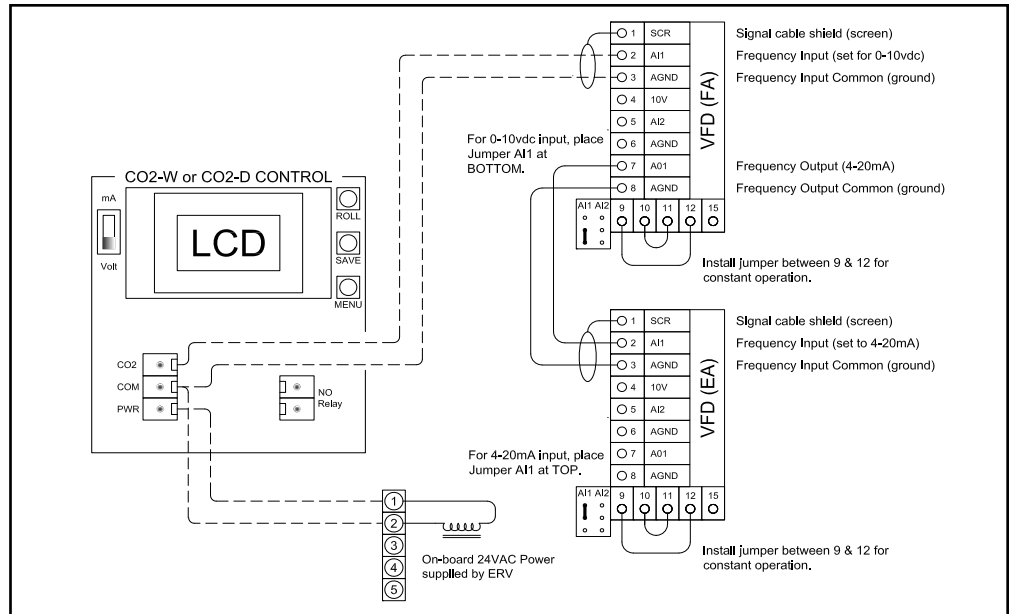

FIGURE 3.1.4 WIRING SCHEMATIC FOR HE-SERIES AND LE-SERIES UNITS WITH FACTORY-INSTALLED VFDs

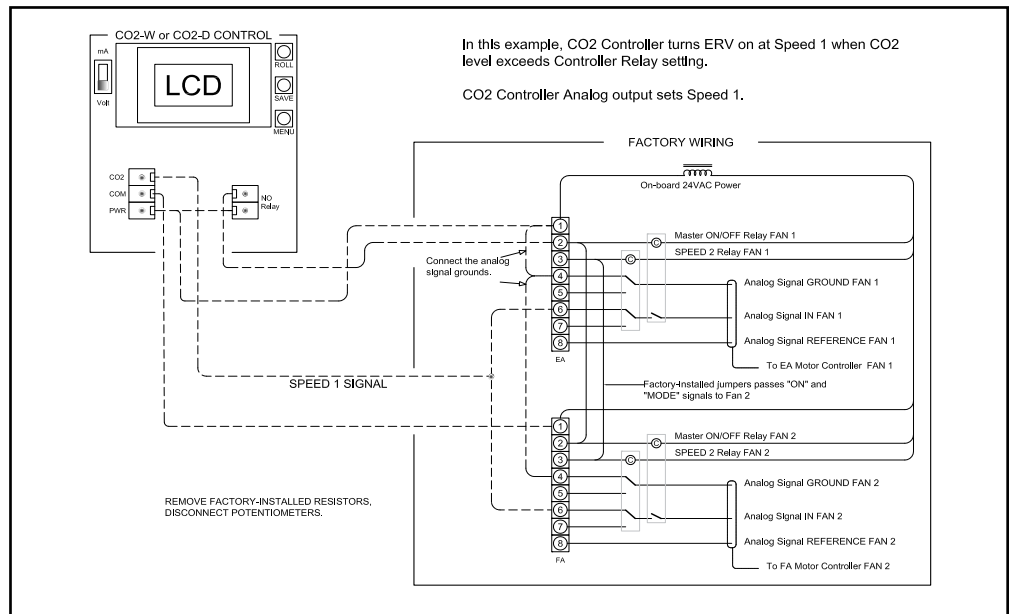

FIGURE 3.1.5 WIRING SCHEMATIC FOR HE1.5 UNITS WITH ECM AND TERMINAL BLOCK

In this example, the CO2 Controller turns the ERV on at speed set by potentiometers when CO2 level exceeds CO2 Controller Relay setting.

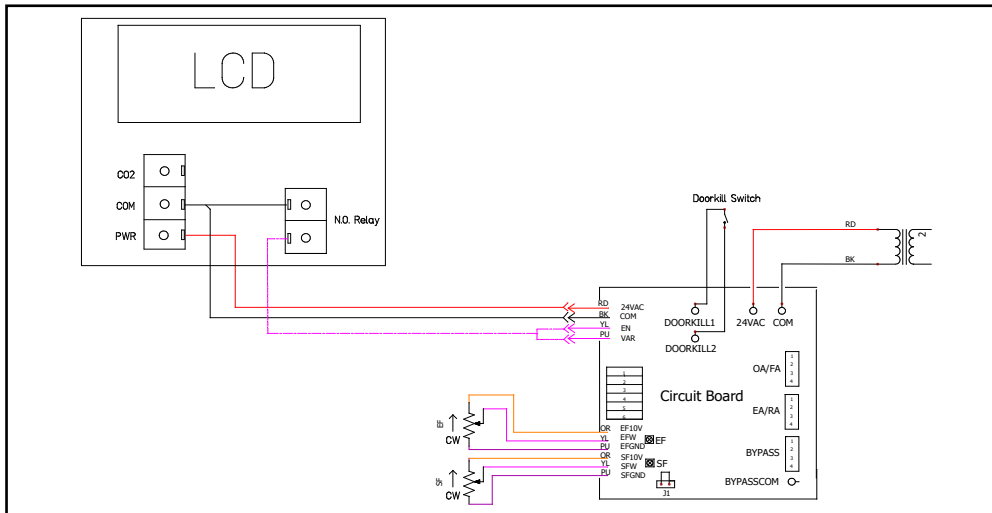

FIGURE 3.1.6 WIRING SCHEMATIC FOR HE07, HE10, AND HE1.5 UNITS WITH ECM AND CIRCUIT BOARD

In this example, the ERV does not run while unoccupied, set by timer. During occupancy, ERV runs at variable Speed. CO2 Controller sets speed based on CO2 levels. Remove the potentiometers by cutting the wires at the potentiometer. Cap the orange and purple wires from the potentiometer with wire nuts. HE07, HE10, and HE1.5 Circuit Board has two potentiometers and the cut wires can be wired in parallel back to the CO2 Controller.

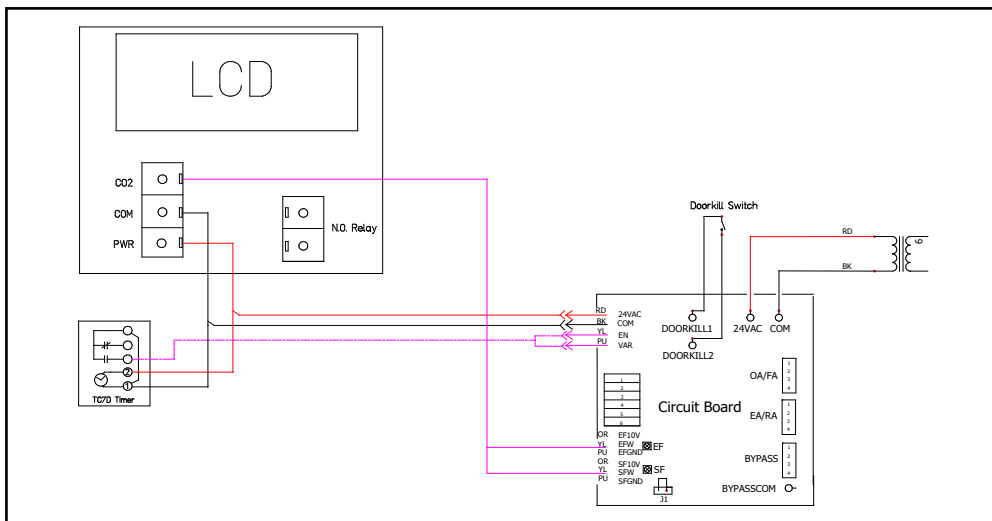

FIGURE 3.1.7 WIRING SCHEMATIC FOR HE07, HE10, AND HE1.5 UNITS WITH ECM AND CIRCUIT BOARD AND TIMER

4.0 FACTORY ASSISTANCE

In the unlikely event that you need assistance from the factory for a specific issue, make sure that you have the information called for in the Unit Records page in the Owner Information section of the unit manual. The person you speak with at the factory will need that information to properly identify the unit and the installed options.

To contact RenewAire Customer Service:

Call 800-627-4499

Email: RenewAireSupport@RenewAire.com



About RenewAire

For over 40 years, **RenewAire has been a pioneer in enhancing indoor air quality (IAQ)** in commercial and residential buildings of every size. This is achieved while maximizing sustainability through our fifth-generation, static-plate, enthalpic-core **Energy Recovery Ventilators (ERVs) that optimize energy efficiency**, lower capital costs via load reduction and decrease operational expenses by minimizing equipment needs, resulting in significant energy savings. Our ERVs are competitively priced, simple to install, easy to use and maintain and have a quick payback. They also enjoy the industry's best warranty with the lowest claims due to long-term reliability derived from innovative design practices, expert workmanship and **Quick Response Manufacturing (QRM)**.

As the pioneer of static-plate core technology in North America, RenewAire is the largest ERV producer in the USA. We're **committed to sustainable manufacturing** and lessening our environmental footprint, and to that end our Waunakee, WI plant is 100% powered by wind turbines. The facility is also one of the few buildings worldwide to be LEED® Gold and Green Globes certified, as well as having achieved ENERGY STAR Building status. In 2010, RenewAire joined the Soler & Palau (S&P) Ventilation Group in order to provide direct access to the latest in energy-efficient air-moving technologies. For more information, visit: renewaire.com

201 Raemisch Road | Waunakee, WI | 53597 | 800.627.4499 | RenewAire.com