

Service Manual

Ventilating Fan
(North America Market)

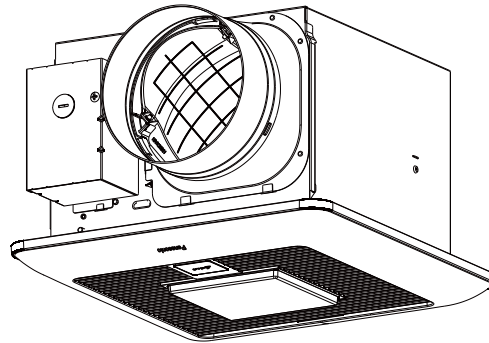

FV-1115VKL2

⚠ WARNING

This service information is designed for experienced repair technicians only and is not designed for use by the general public. It does not contain warnings or cautions to advise non-technical individuals of potential dangers in attempting to service a product. Products powered by electricity should be serviced or repaired only by experienced professional technicians. Any attempt to service or repair the product or products dealt with in this service information by anyone else could result in serious injury or death.

IMPORTANT SAFETY NOTICE

There are special components used in this equipment which are important for safety. These parts are marked by ⚠ in the Schematic Diagrams, Exploded Views and Replacement Parts List. It is essential that these critical parts should be replaced with manufacturer's specified parts to prevent shock, fire or other hazards. Do not modify the original design without the manufacturer's approval.

Please have a static electricity depletion process in place before handling these components..

Please use gloves when handling PCB parts during the repair process..

CONTENTS	PAGE
1.Specification.....	1
2.Parts Identification.....	2 ~ 5
3.Wiring Diagram.....	6
4.Parts List.....	7 ~ 8

1. Specification

■ Specification for base Model fans

Model No.	Air Direction	Voltage (V)	Frequency (Hz)	Duct Diameter (inches)	Air Volume at 0.1 "WG (CFM)	Noise (sones)	Speed (rpm)	Power (W)		Weight Lb. (Kg)
								Fan	Lighting unit	
FV-1115VKL2	Exhaust	120	60	6	150	0.5	722	14.9	10	10.7 (4.9)
					130	<0.3	682	10.4		
					110	<0.3	648	7.5		

HVI Certified performance based on HVI Procedures 915, 916, and 920.

■ Specifications for Multi Speed fans

Model No.	Air Direction	Voltage (V)	Frequency (Hz)	Duct Diameter (inches)	Air Volume at 0.1 "WG (CFM)	Noise (sones)	Speed (rpm)	Power (W)		Weight Lb. (Kg)
								Fan	Lighting unit	
FV-1115VKL2	Exhaust	120	60	6	120	<0.3	670	8.4	10	10.7 (4.9)
					110	<0.3	648	7.5		
					100	<0.3	636	6.0		
					90	<0.3	627	5.0		
					80	<0.3	625	4.6		
					70	<0.3	613	3.8		
					60	<0.3	610	3.3		
					50	<0.3	621	3.1		
					0	–	–	0.5 (*)		

Reference performance based on HVI Procedures 915, 916, and 920. [(*) Standby wattage.]

2. Parts Identification

FV-1115VKL2

Main Body Section

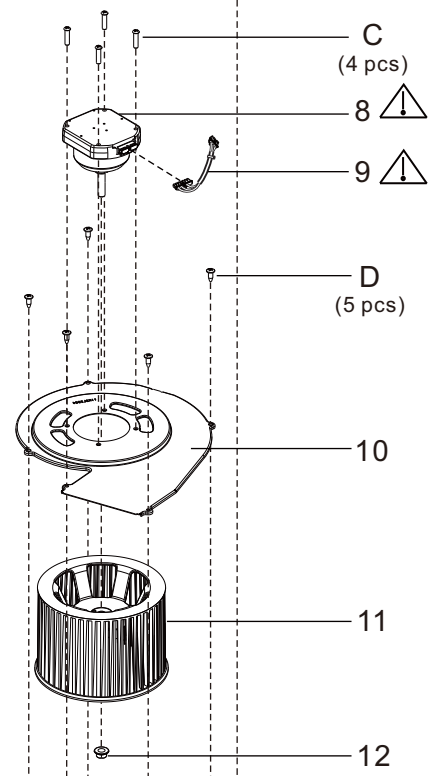
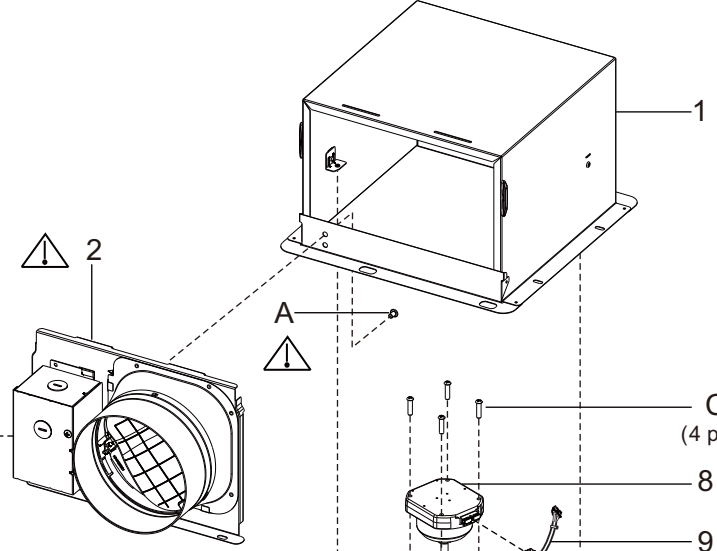
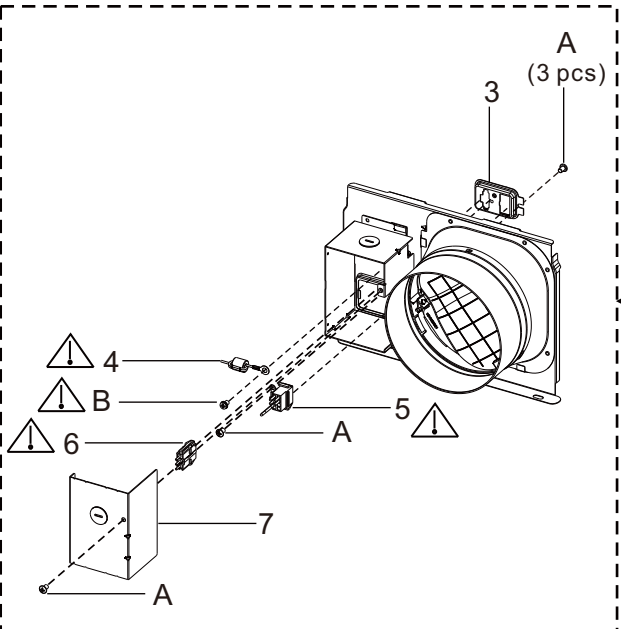

Main PCB Section

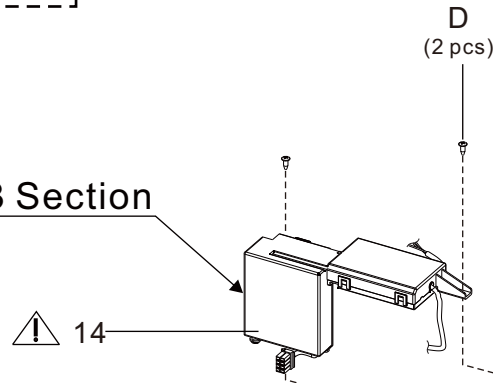

Base PCB Section

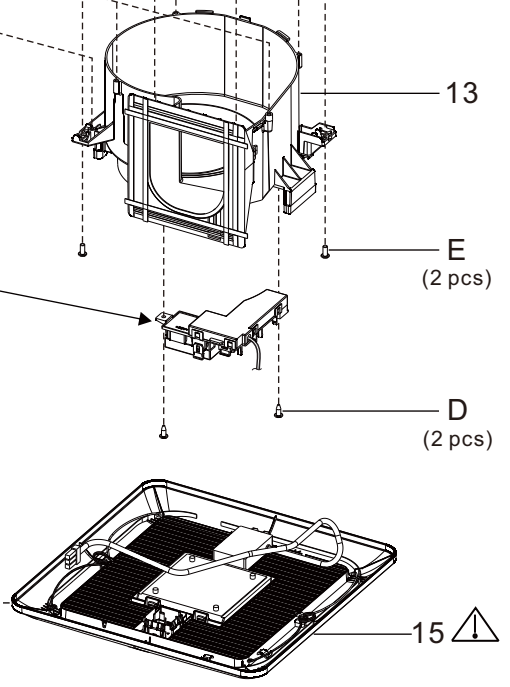
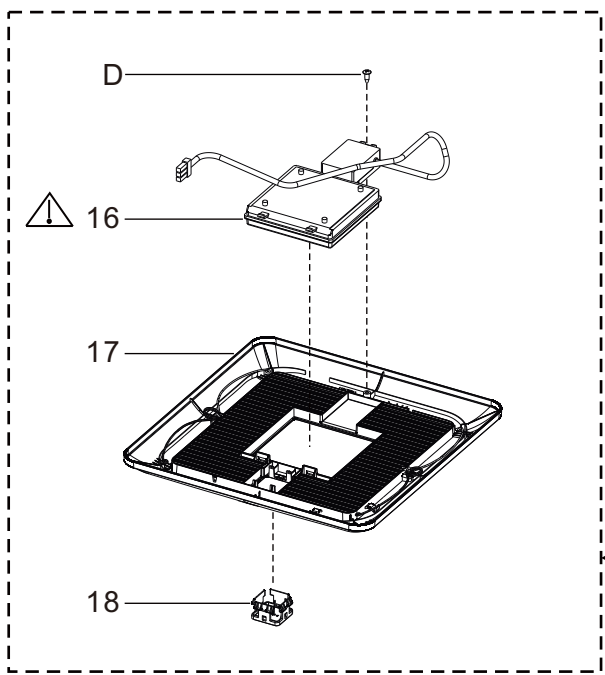

2.Parts Identification

FV-1115VKL2

Main PCB Section

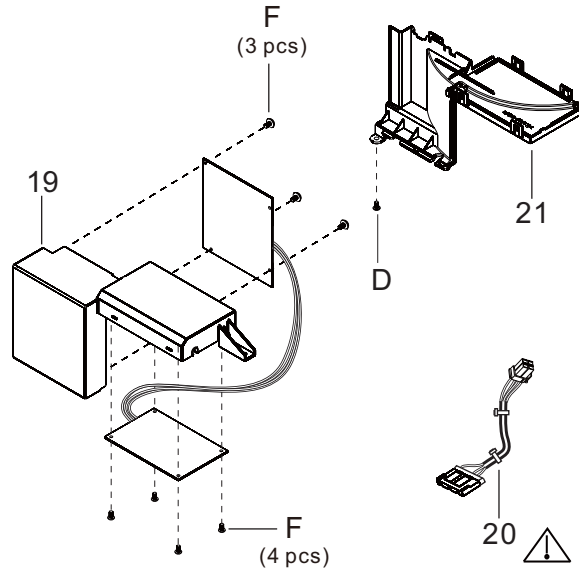

Base PCB Section

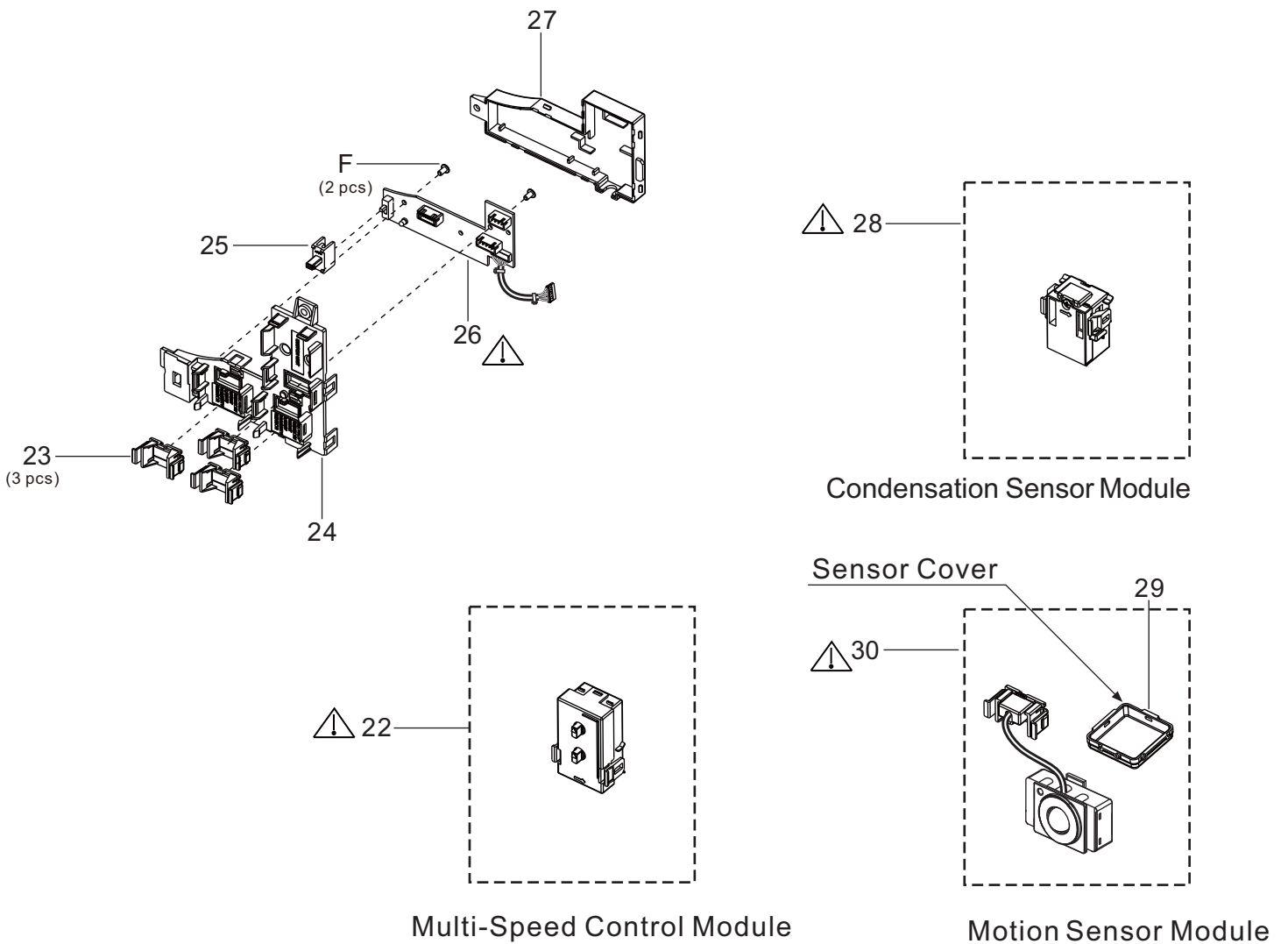

1, Please note that above parts with (No. 22, 28, 30) are the optional parts base on Different customer's request.

2, If install the motion sensor control, please remove the ornamental cover and Replace the sensor Cover.

2. Parts Identification

FV-1115VKL2

Packing Section

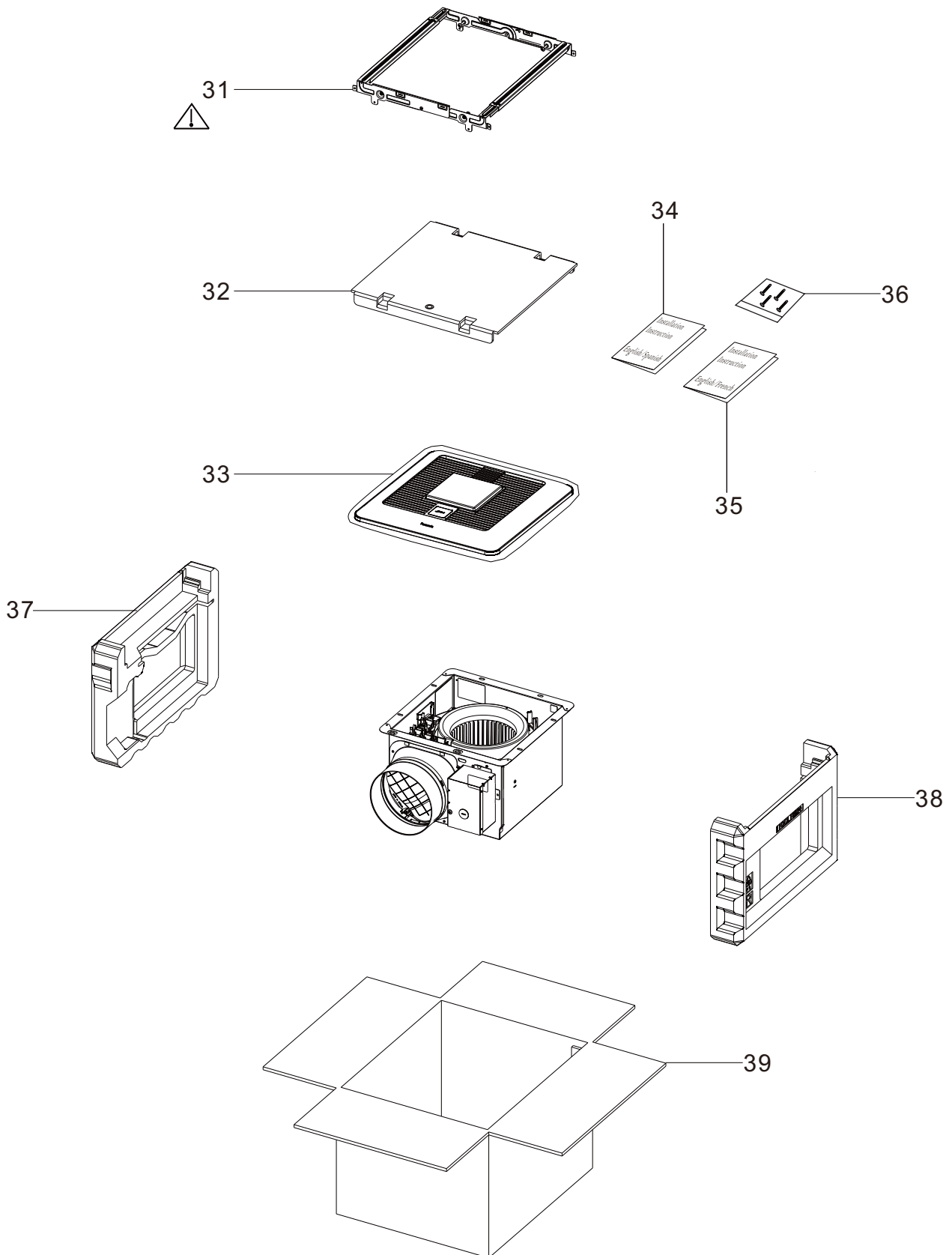

2. Parts Identification

FV-1115VKL2

Main Label

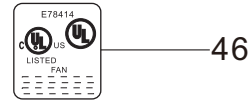
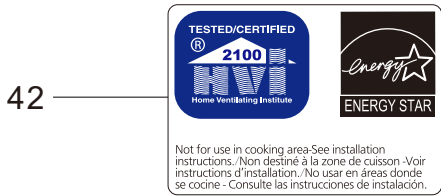
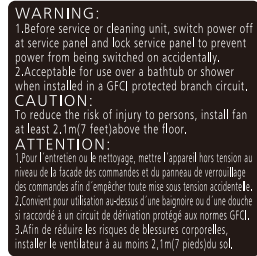

3. Wiring Diagram

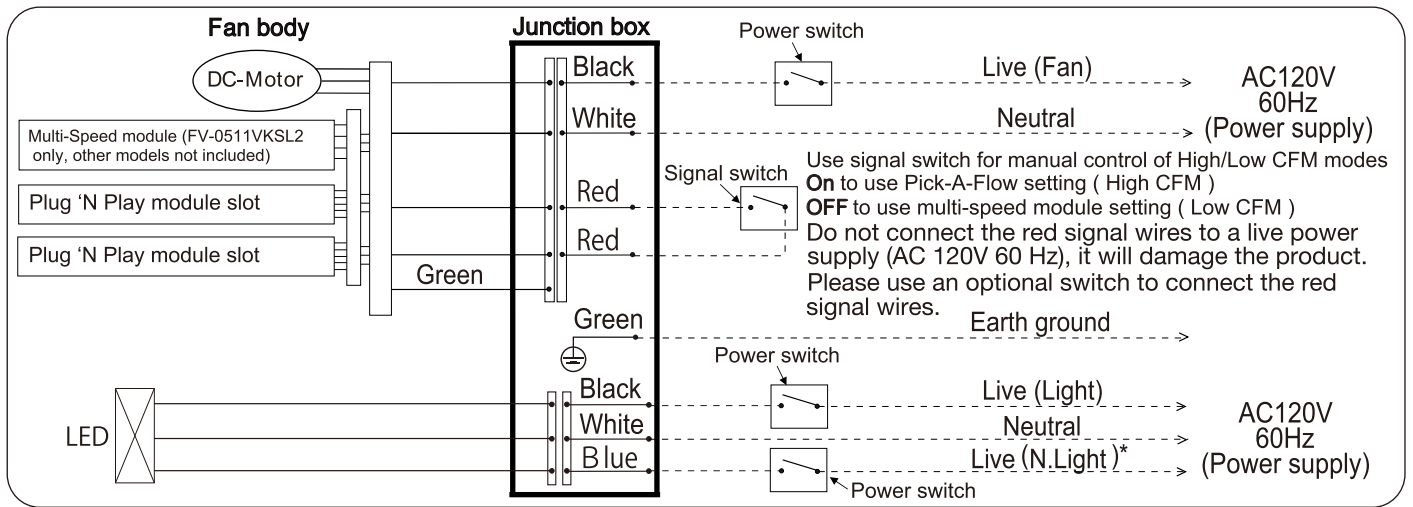

*Night light

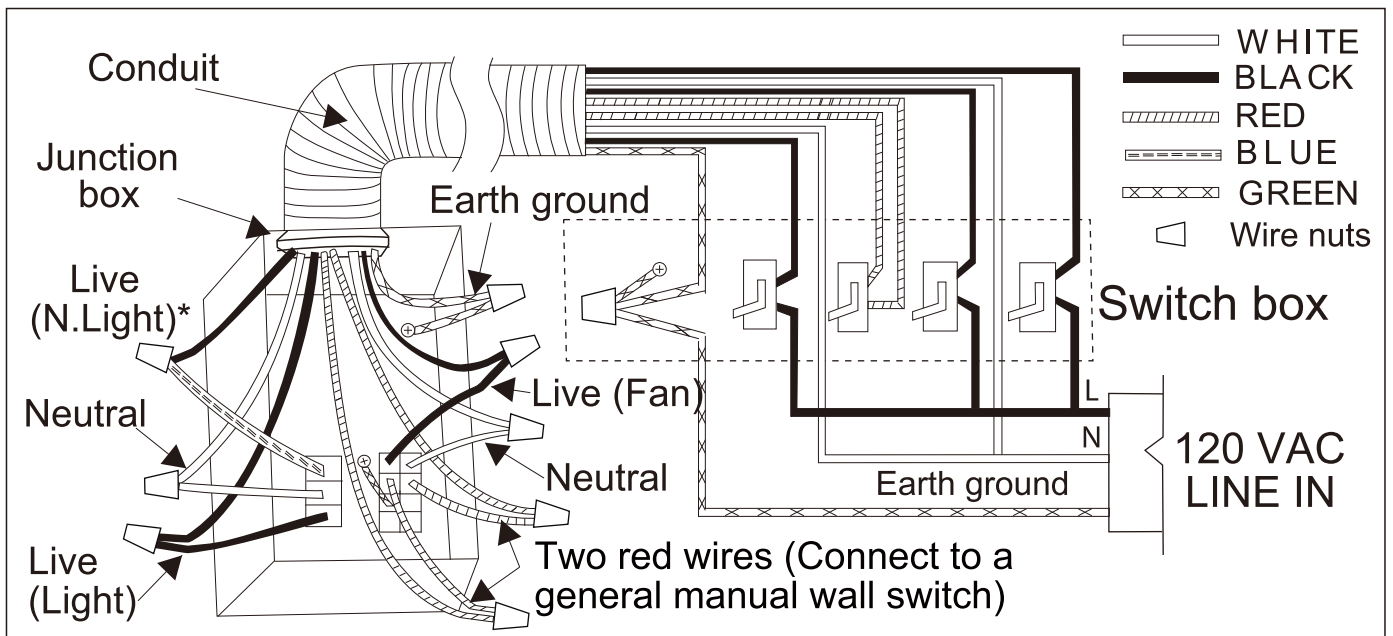

* Night Light

4. Parts List

FV-1115VKL2

Main Body Section

No.	Part No.	Part Name	Q'ty	Remark
1	FFV11QCL1900C	Frame Assembly	1	
2	FFV15VKL2910	Adapter Assembly	1	△
3	FFV11KSL2913	Connector Plate	1	
4	FFV1340008S	Ground Wire	1	△
5	FFV11KSL2301	Connector Assy	1	△
6	FFV11QCL1341A	Connector Assy (L)	1	△
7	FFV11QCL1912A	Junction Cover	1	
8	FFV11KSL2M20	Motor	1	△
9	FFV4620109S	Motor Lead Wire Assembly	1	△
10	FFV15VK20904	Motor Support	1	
11	FFV0400115S	Blade	1	
12	FFV7020021S	Nut	1	
13	FFVM15VQ10906B	Casing section	1	
14	FFV1115VKL2PCB	Main PCB Section	1	Include Base PCB Section △
15	FFV0511VKSL2	Grill Assembly	1	△
16	FFV3400148S	Led Unit	1	△
17	FFV0511VQCL1S	Grill Section	1	
18	FFV2220074S	Ornamental Cover	1	
A	FFVXTT4-8FFJ	Screw (ST4-8)	4	△
B	FFVXYM4DC8BN	Screw w/washer(M4-8)	1	△
C	FFV7000109S	Stainless Steel Screw	4	
D	FFV7000089S	Screw (ST4-12)	10	
E	FFV7000065S	Bind Screw	2	△

Main PCB Section

No.	Part No.	Part Name	Q'ty	Remark
19	FFV3740027S	Main PCB Box	1	
20	FFV11KSL2310	Power Lead Wire	1	△
21	FFV3740014S	Main PCB Cover	1	
D	FFV7000089S	Screw (ST4-12)	1	

4. Parts List

FV-1115VKL2

Base PCB Section

No.	Part No.	Part Name	Q'ty	Remark
22	FFV5530071S	Multi-Speed Module	1	⚠
23	FFV0900063S	Connector Cover	3	
24	FFV0410001S	Base PCB Cover	1	
25	FFV5530072S	Variable Speed Switch	1	
26	FFV0410002S	Base PCB Assembly	1	⚠
27	FFV0410003S	Base PCB Box	1	
28	FFV0010237S	Condensation Sensor Module	1	⚠
29	FFV2220051S	Sensor Cover	1	
30	FFV3740029S	Motion Sensor Module	1	Include Sensor Cover ⚠
F	FFVXTN3-8GFJ	Screw (M3-8)	2	

Packing Section

No.	Part No.	Part Name	Q'ty	Remark
31	FFV11QCL1920	Hanger Assy	1	⚠
32	FFV4710381S	Grill Pad Assy	1	
33	FFV4650016S	Poly Cover	1	
34	FFV11KSL2420	Installation Inst	1	English / Spanish For USA Market
35	FFV11KSL2421	Installation Inst	1	English / French For CANADA Market
36	FFV11KSL1M031A	Accessory A	1	
37	FFV11QCL1891	Left Pad	1	
38	FFV11QCL1892	Right Pad	1	
39	FFV15VKL2400	Packing Case Assy	1	

Main Label

No.	Part No.	Part Name	Q'ty	Remark
40	FFV11KSL2012	CFM Label	1	
41	FFV15VKL2050	Name Plate	1	
42	FFV0810011S	Caution Label 1	1	
43	FFV11KSL2055	QR Code Label	1	
44	FFV0810010S	Caution Label	1	
45	FFV6730045S	Warning Label	1	
46	FFV2260003S	Holograph Label	1	