

## REVITALIZES AND ENERGIZES AIR CONDITIONING SYSTEMS. USE WITH ALL REFRIGERANTS.

- **Quiets noisy compressors.**
- **Reduces energy consumption, lowers starting and running amps.**
- **Frees sticking thermostatic expansion valves and reversing valves.**
- **Aids in oil return/heat transfer with R-410A, R-407C and R-22 drop-ins.**
- **Great for new and old systems.**

### Description

A/C Re~New has been used successfully for many years to improve the performance of air conditioning and refrigeration systems. A/C Re~New provides significant saving in energy use. It also quiets noisy systems and extends the life of the system. It is a lubricant that blends with the system's oil, lasting for the life of the equipment, or until the oil is changed.

### Application

A/C Re~New can be used in air conditioning as well as refrigeration applications. It is formulated for use with R-22, R-410A as well as other refrigerants. The 4 oz. package can be used to treat systems up to 5 tons. For large commercial systems, such as packaged units or larger refrigeration systems, multiple bottles should be used. Additionally, the product is available in 32 oz. quarts. Install with the A/C Re~New Injector.

### Packaging

1 quart (32 fl. oz.)	<b>4057-54</b>
4 fluid ounce can	<b>4057-55</b>
A/C Re~New Injector Tool	<b>4057-99</b>

## Refrigeration Oil

### A/C Re~New



### A/C Re~New in the Compressor

- ✓ Improved lubricity through reduced friction drag
- ✓ Cleaner system
- ✓ Quieter Operation

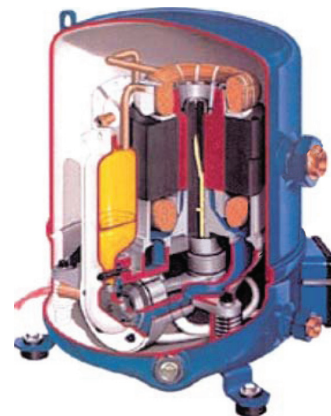
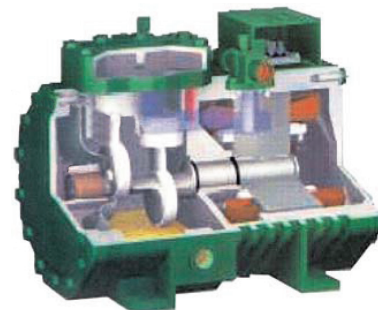

## A/C Re~New Technology Testing Results

Residential air conditioning systems account for up to 70% of the home's energy consumption. And when the outdoor temperature rises, the system works longer and harder. Through tests on actual installations\*, the A/C Re~New technology has demonstrated its ability to reduce the air conditioning systems energy use on average by 11%. It has also been found to improve the system's cooling performance and quiet noisy systems.

### Energy Savings

Number of units tested	Outdoor Temperature	Average Running amps Before A/C Re~New	Average Running amps After A/C Re~New	% Savings
26	73.3°F	15.8	14.1	10.8%
12	56.4°F	17.4	16.5	5.2%

\* Data available upon request.

### Noise Reduction

Average Decibel Before A/C Re~New	Average Decibel After A/C Re~New	Decibel Drop
77.08	75.12	1.96

### Cooling Performance

Average Air Duct Temp. Before A/C Re~New	Average Air Duct Temp. After A/C Re~New	Temperature Drop
57.4°F	54.2°F	3.2°F

### Falex Pin Test

This test is used to evaluate wear and tear, friction and extreme pressure properties of materials and lubricants. A rotating pin, also referred to as a journal, is lubricated with the test product and is compressed between two V-shaped blocks. Pressure (depicted by the red arrows) is added at increasing levels until the pin fails. The goal is to determine how much load or force the lubricant can withstand before it fails. Therefore, the higher the load, the better the lubricant. Three typical industry oils (Mineral Oil, Alkylbenzene and POE) were tested, both alone and then mixed appropriately with the product. A/C Re~New significantly improved the oil's load-to-failure points.

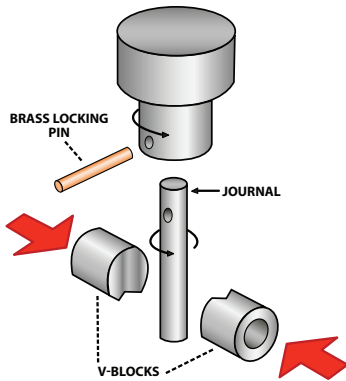

Falex Pin & V-Block Testing Results

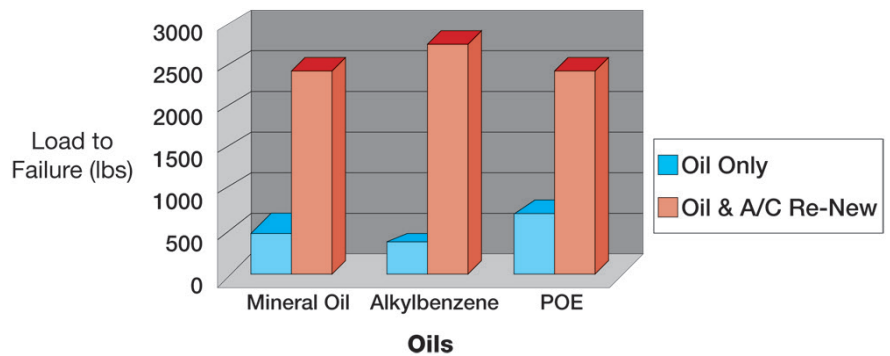

Reciprocating - Upper Journal

### Compressor Wear Test

This test evaluated how well A/C Re~New reduced metal wear in operating compressors. Six reciprocating compressors were tested with R-22 refrigerant and mineral oil for a period of 500 hours. A/C Re~New was applied to half of the compressors. As shown in the pictures to the right, the bearing wear on the compressors was significantly reduced in those compressors containing A/C Re~New. Less wear means the equipment will last longer and reduced friction results in lower energy consumption. Similar results were achieved in scroll compressors (photos available).

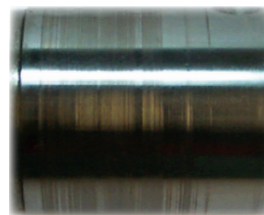

Without A/C Re~New

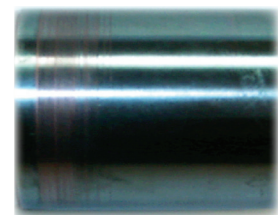

With A/C Re~New  
Fewer Scars

## A/C Re~New Directions for Use - General Guidelines

- One can will treat systems up to 5 tons
  - Multiple cans should be used to treat larger commercial systems; including packaged units, split systems, etc.
1. Confirm that you have all the required items for the application.
  2. Use one can of A/C Re~New for up to 5 tons of system capacity. For larger systems, multiple cans should be used. And for system capacities that fall between multiples of 5 tons (3 tons, 7 1/2 tons, etc.), round up to the next multiple of 5 tons to determine the required charge of A/C Re~New. For example, use two cans to treat 7 1/2 tons. The slightly higher dose of A/C Re~New is nominal and considered acceptable.
  3. Oil removal. For systems over 10 tons, it is recommended that 4 fluid ounces of system oil be removed for every 5 tons of capacity. For example, remove 12 fluid ounces of oil from a 15 ton system, and install three cans of A/C Re~New.
  4. Be sure to exercise and use good air conditioning, refrigeration service practices at all times. Install with the A/C ReNew Injector Tool.

## A/C Re~New Injector Tool - Directions for Use

The A/C Re~New Injector was designed to inject A/C Re~New into air conditioning and refrigeration systems. It has a capacity of 4 fl. oz. and can be used for other injectable products as well. It is constructed of rugged aluminum and has a maximum working pressure of 600 psi. It has a Schrader fitting at one end and hand valve with a short length of hose at the other end.

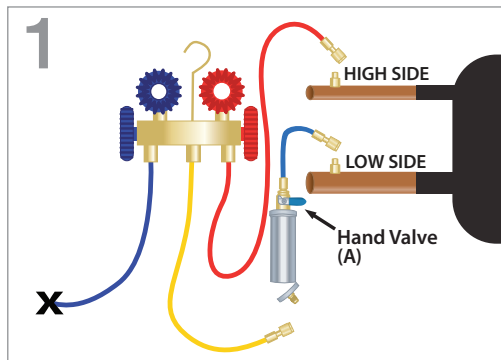

### STEP 1:

- Make sure system is running and low side and high side service ports are properly identified. If unit is a heat pump, be sure it is in cooling mode. Hand-valve (A) must be closed.
- Unscrew the aluminum injector cap with 1/4" male inlet fitting.
- Connect the 1/4" SAE fitting of blue hose to suction service port of system.
- Crack open hand valve (A) on injector to chase the remaining air out of the blue hose, then close hand valve (A).

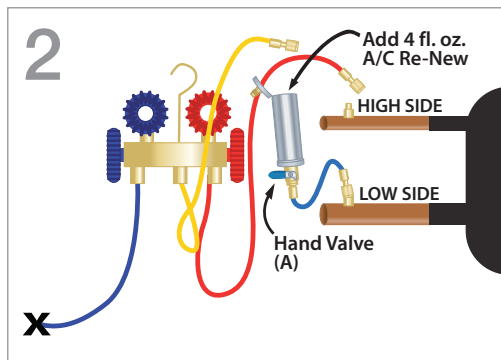

### STEP 2:

- Pour in 4 fl. oz. of Nu-Calgon A/C Re~New.
- Recap the A/C Injector with the aluminum cap with 1/4" male inlet fitting. Make sure the cap is hand tight to ensure a good seal is made at the cap.

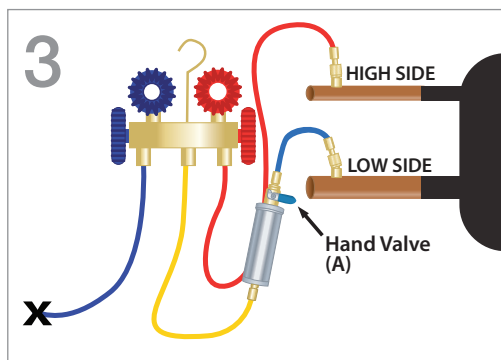

### STEP 3:

- Make sure both valves on gauge set are closed. Connect high side (red) line of manifold gauge set to the high side service port.
- Barely thread the middle manifold hose (yellow) to the 1/4" male inlet fitting of the A/C Re~New Injector Tool (side opposite of the valve/blue hose). Do not thread to the point of depressing the Schrader core.
- Briefly crack open high side manifold valve to purge air out of the yellow hose, then quickly tighten yellow hose fitting at the injector, and close high side manifold valve.

**STEP 4 CONTINUED ON THE NEXT PAGE.**

4

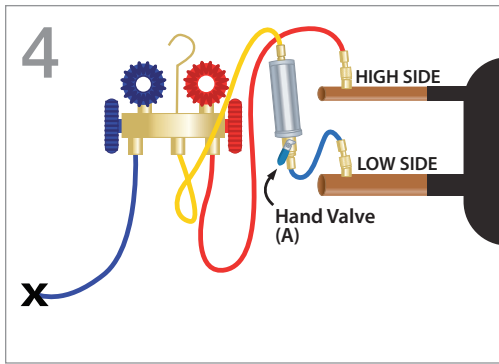

**STEP 4:**

- Open injector hand valve (A) so A/C Re~New will be allowed to flow from injector into the low side of the system.
- Briefly open high side valve of the manifold gauge set to allow a little high side liquid to flow through the yellow hose/injector. Close high side manifold valve. Repeat process as necessary for a one minute duration for A/C Re~New to be fully injected into the low side of the system.
- Close high side valve of the manifold gauge set and wait an additional one minute for the injector assembly to equalize to suction pressure.
- Fully close hand valve (A) on A/C Re~New Injector and remove blue hose from suction service port.
- Once disconnected from system, slowly open hand valve (A) on injector so it equalizes the assembly to atmospheric pressure - ensure outlet fitting is pointed toward the ground. Close hand valve (A).
- Ensure injector remains capped to prevent contamination on its next use.

Read and understand the product's label and Safety Data Sheet ("SDS") for precautionary and first aid information. The SDS is available on the Nu-Calgon website at [www.nucalgon.com](http://www.nucalgon.com).

