



325 COMMERCE DRIVE
 MT VERNON, OH 43050
 800-253-8236

SPECIFICATION DATA SHEET

DATE: 5-24-13
 PREPARED BY: RL

MODEL NO. 604

SADDLE TEE W/GASKET & DAMPER

STANDARD MODEL

DIMENSIONS

SIZE				
A	Min Ø B	Max Ø B	C	
4"	on 6"	to 9"	6"	
4"	on 10"	to 20"	6"	
5"	on 12"	to 20"	6"	
6"	on 8"	to 9"	6"	
6"	on 10"	to 20"	6"	
7"	on 7"	to 8"	6"	
7"	on 9"	to 12"	6"	
7"	on 14"	to 20"	6"	
8"	on 10"	to 12"	6"	
8"	on 14"	to 20"	6"	
10"	on 10"	to 11"	6"	
10"	on 12"	to 14"	6"	
10"	on 16"	to 20"	6"	
12"	on 14"	to 16"	6"	
12"	on 18"	to 22"	6"	
14"	on 16"	to 18"	6"	
16"	on 18"	to 20"	6"	
18"	on 24"	to 28"	6"	

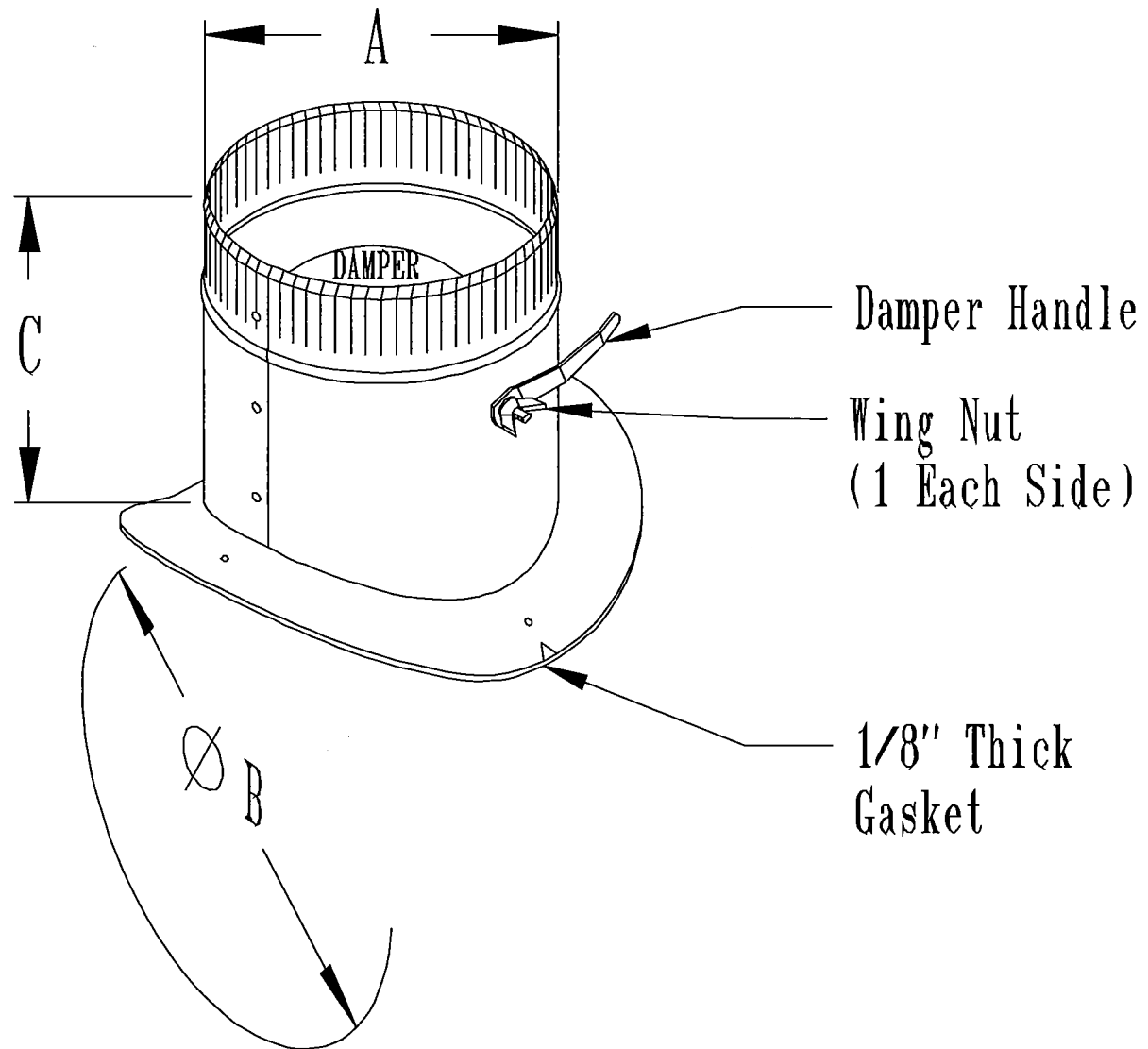

MATERIAL SPECIFICATIONS

HOT DIPPED GALVANIZED STEEL.
 PER ASTM A 653 CSB.

ASSEMBLED WITH 1/8" ZINC COATED RIVETS.

BODY & SADDLE: PIPE SIZE 4" - 8" = STD GA MINIMUM
 BODY & SADDLE: PIPE SIZE 9" - 16" = 28 GA MINIMUM
 BODY & SADDLE: PIPE SIZE 18" & UP = 26 GA MINIMUM

DAMPER: 4" - 8" = 28GA MINIMUM
 DAMPER: 10" - 12" = 26GA MINIMUM
 DAMPER: 14" & UP = 26GA MINIMUM

DAMPER HANDLE = 18 GA

WINGNUT = 5/16-18, ZINC PLATED STEEL

GASKET IS CROSSLINKED POLYETHYLENE.

OPTIONS

2IN STANDOFF AVAILABLE
 DOUBLE WINGNUT AVAILABLE
 HEAVIER GAUGES AVAILABLE

JOB: _____
 LOCATION: _____
 CONTRACTOR: _____
 ENGINEER: _____
 NOTES: _____