

ULTRA-ZONE[®]

Forced Air Zone Controls

SUBMITTAL SHEET

Model ND-L Rectangular Dampers

Constructed from Heavy Duty extruded aluminum.

Glass Filled Nylon Bearings for quiet, maintenance free operation.

Overlapping parallel blades for low leakage.

Designed to operate at static pressures up to 1.5" w.g.

Damper Drive Blade has a 5/8 inch diameter shaft that is 1.75 inches in length.

Anti-Rotation Bolt is 1/2 inch in length and has a 10/32 Thread.

Dampers are available in 8" x 6" thru 30" x 30" in one inch increments. Custom Sizes can be manufactured, contact EWC Controls Inc. for more information.

DIMENSIONAL DRAWINGS

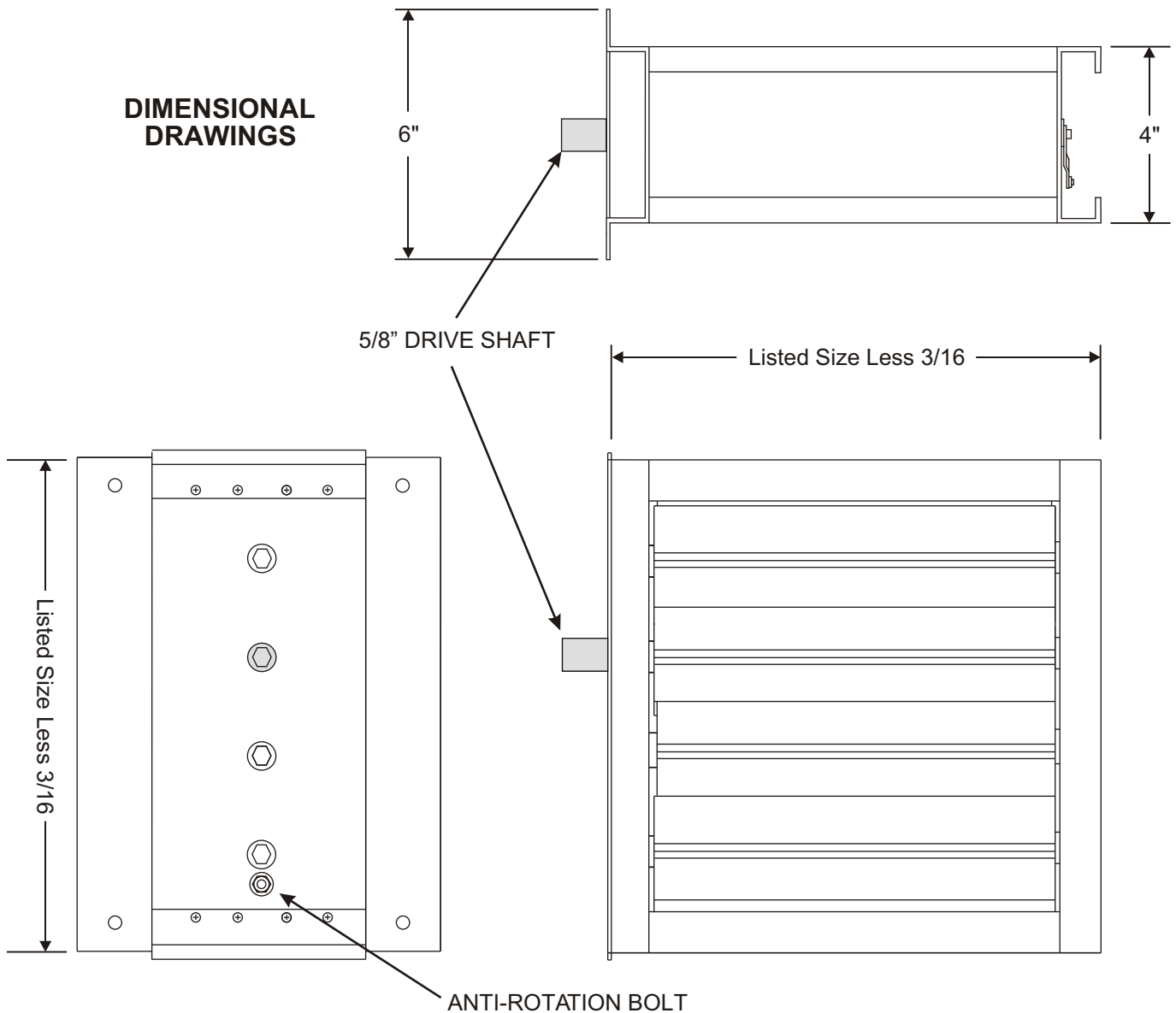

SUBMITTAL FORM

SUBMITTED BY: _____

JOB: _____

ARCHITECT: _____

ENGINEER: _____

CONTRACTOR: _____

LOCATION: _____

Excellence Without Compromise

EWC[®]
CONTROLS INC.

385 Hwy. 33
Englishtown, NJ 07726
Ph: 800-446-3110
Fx: 732-446-5362

DAMPER INSTALLATION

On the side of the duct, where the damper is to be mounted, cut a 4.25" wide slotted opening. Slide the damper into the opening and secure the damper to the duct with the sheet metal screws. *Airflow can be from either direction and the Motor can be oriented in any position.* Larger sizes may require additional support by securing the back of the damper. If using duct board, additional support can be obtained by using Model DBA Duct Board Adaptors.

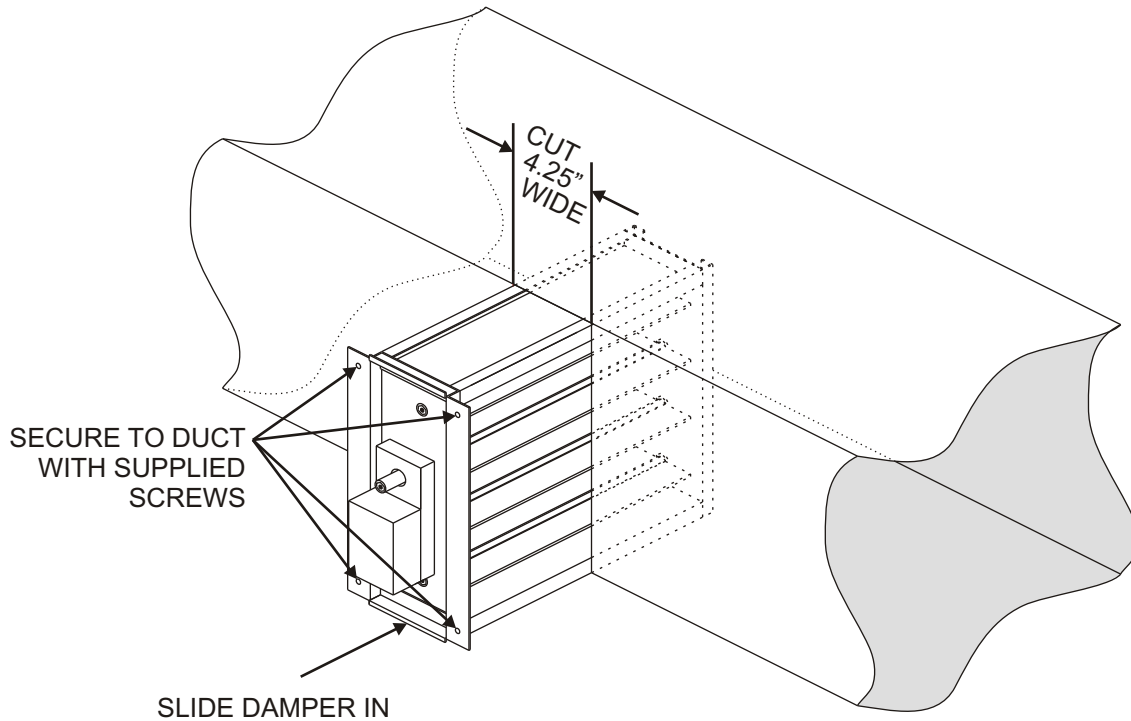

| MOTOR ACTUATOR OPTIONS | | | |
|------------------------|---------------------------------------|-------------|-----------------|
| MODEL | DESCRIPTION | TORQUE | SUBMITTAL SHEET |
| ND | STANDARD PO/PC MOTORACTUATOR | 18 In.-Lbs. | 090377A0119 |
| ND-L | LESS MOTOR ACTUATOR | N/A | N/A |
| ND-MQ | MANUAL DAMPER | N/A | 090377A0117 |
| ND-LM24 | HIGH TORQUE PO/PC MOTORACTUATOR | 45 In.-Lbs. | 090377A0120 |
| ND-LM24SR-T | 2-10vdc MODULATING MOTORACTUATOR | 45 In.-Lbs. | 090377A0158 |
| ND-LF24 | HIGH TORQUE 24VAC SR MOTOR | 35 In.-Lbs. | 090377A0159 |
| ND-LF120 | HIGH TORQUE 120VAC SR MOTOR | 35 In.-Lbs. | |
| ND-TF24 | MID TORQUE 24VAC SR MOTOR | 18 In.-Lbs. | 090377A0148 |
| ND-TF120 | MID TORQUE 120VAC SR MOTOR | 18 In.-Lbs. | |
| ND-MA-15s | 15 SECOND DRIVE, PO/PC MOTOR ACTUATOR | 18 In.-Lbs. | 090377A0128 |
| ND-MA-60s | 60 SECOND DRIVE, PO/PC MOTOR ACTUATOR | 18 In.-Lbs. | 090377A0156 |

PO = Power Open; PC = Power Close; SR = Spring Return