

# SUBMITTAL DATA

**Schwank**  
INNOVATIVE HEATING SOLUTIONS



## bistroSchwank 2100 SERIES

**HIGH EFFICIENCY  
INFRARED PATIO HEATER  
FOR OUTDOOR INSTALLATION  
AND HIGH INTENSITY HEATER  
FOR NON-RESIDENTIAL INDOOR USE**

PROJECT:	
ENGINEER:	
CONTRACTOR:	
DISTRIBUTOR:	
SCHWANK MODEL #:	
FUEL:	N.G.                      L.P.G.
APPROVED BY:	
DATE:	
APPROVAL #:	

bistroSchwank 2100 Series is certified by CSA International to:

- ANSI Z83.26 / CSA 2.37 Standard for Gas-Fired Outdoor Infrared Patio Heaters
- ANSI Z83.19b / CSA 2.35b Standard for Gas-Fired High-Intensity Infrared Heaters



**NOTICE:**

Schwank reserves the right to make changes to equipment and specifications without obligation or notification.

This publication, or parts thereof, may not be reproduced in any form, without prior written consent from Schwank. Unauthorized use or distribution of this publication is strictly prohibited.

Schwank

5285 Bradco Blvd.,  
Mississauga, Ontario,  
L4W 2A6

2 Schwank Way  
Waynesboro, Georgia,  
USA 30830

Customer and Technical Services

Phone: 1-877-446-3727

Fax : 1-866-361-0523

Email: [csr@schwankgroup.com](mailto:csr@schwankgroup.com)

**[www.schwankgroup.com](http://www.schwankgroup.com)**

**APPROVALS:**

The 2100 Series heater has been tested and approved by CSA International:

- For Outdoor Use: ANSI Z83.26-CSA 2.37 Gas-fired Outdoor Infrared Patio Heaters
- For Indoor Use: ANSI Z83 19-CSA 2 35 Gas-fired High-Intensity Infrared Heaters

**DIMENSIONS / SPECIFICATIONS 2100 SERIES**

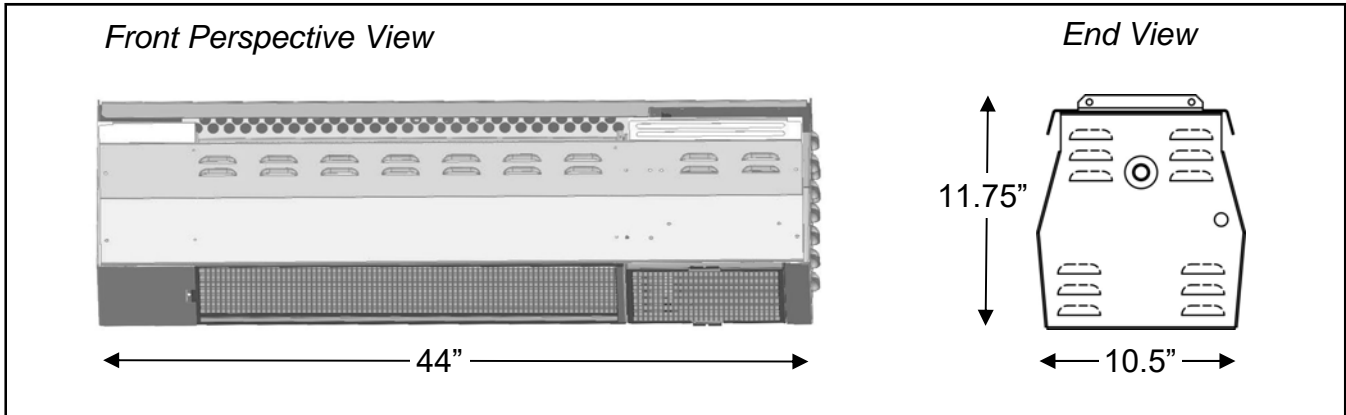

JOB QTY	MODEL NO.	INPUT BTUH	GAS	FINISH		1/2" GAS INLET PIPE SIZE		MANIFOLD PRESSURE	ELECT-RICAL	WEIGHT (LBS.)
				HIGH TEMP. BLACK	MARINE STAIN-LESS	MINIMUM GAS LINE PRESSURE	MAXIMUM GAS LINE PRESSURE			
	2135-N	35,000	NAT			6" W.C.	14" W.C.	5" W.C.	VOLT-AGE 24VAC	32
	2135-L	35,000	LP			11" W.C.	14" W.C.	10" W.C.		32
	2150-N	50,000	NAT			6" W.C.	14" W.C.	5" W.C.	CUR-RENT AMPS 40VA*	44
	2150-L	50,000	LP			11" W.C.	14" W.C.	10" W.C.		44
	2152-N	50,000/ 36,500	NAT			6" W.C.	14" W.C.	5" W.C.		44

\* Transformer required for a multiple heater installation:

- The first heater requires 40 VA and each additional heater 20 VA
- The sum total will be the required rating of the system or zone Transformer
- If total VA required is between transformer rating sizes, select the next higher VA rated transformer.

**MODEL 2152 2-STAGE CONTROL**

2-Stage model heater(s) 2152 must be controlled using "OFF-ON-ON" switch sequence. This sequence is necessary for heater operation. Schwank offers the following control switch options with brushed stainless steel wall plate:

JM-0201-TS   
Control one 2-stage heater or one zone of up to 4 heaters.  
QUANTITY:

JM-0202-TS   
Control two 2-stage heaters or two zones up to 4 heaters/zone.  
QUANTITY:

JM-0203-TS   
Control three 2-stage heaters or 3 zones up to 4 heaters/zone.  
QUANTITY:

**MINIMUM CLEARANCE TO COMBUSTIBLES**

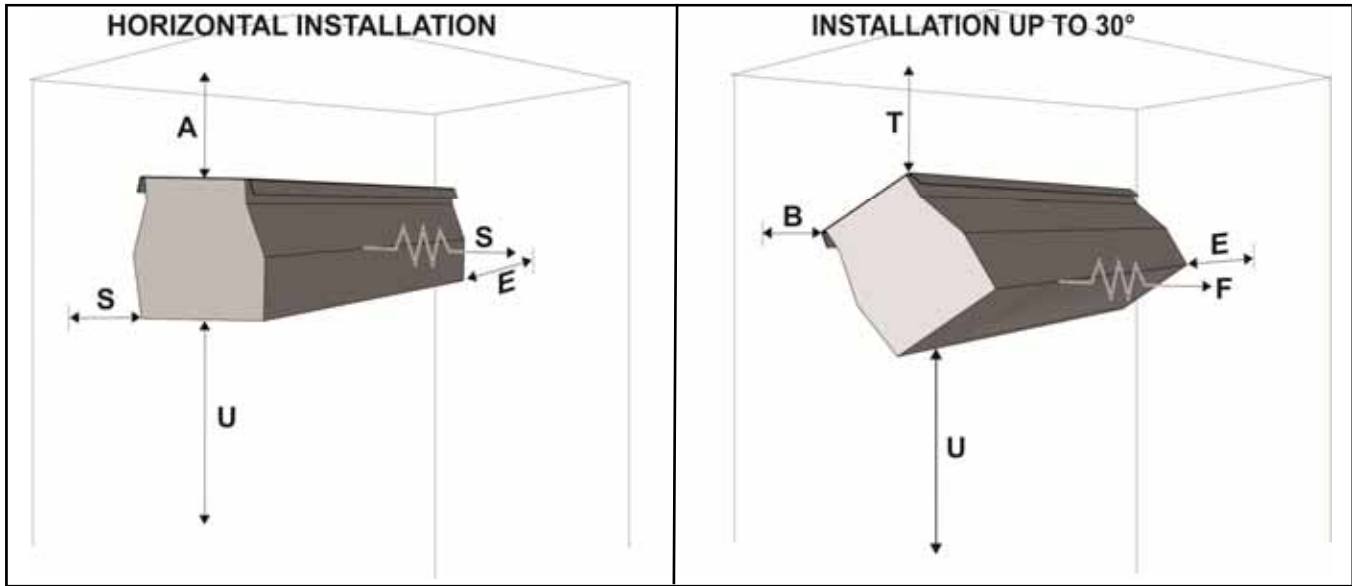

Note: Ensure mounting height in any location is sufficient to prevent patrons from coming in contact with heater, and clearance to combustible material is maintained.

QTY	Application	MODEL NO	Ends	Under	Horizontal		30° Angle		
			E	U	A	S	T	B	F
	OUTDOOR	2135 -N\L	14"	45"	13"	14"	9.5"	9"	60"
	OUTDOOR	2150 -N\L	14"	60"	16"	19"	20"	8"	62"
	OUTDOOR	2152 -N	14"	60"	16"	19"	20"	8"	62"
	INDOOR	2135 -N\L	14"	45"	18"	18"	14.5"	11"	60"
	INDOOR	2150 -N\L	14"	60"	21"	23"	20"	10"	62"
	INDOOR	2152 -N	14"	60"	21"	23"	25"	10"	62"

**Do not mount less than 8 ft [2438 mm] above floor.**

**Do not store or place anything directly under heater**

Notes:

1. The clearance to combustible material represents the minimum distance that must be maintained between the outer heater surface and a nearby surface. The stated clearance to combustibles represents a surface temperature of: **Indoor** = 90F° (50C°) above room temperature; **Outdoor** = 117F° (65C°) above ambient temperature.
2. It is the installer’s responsibility to ensure that building materials with a low heat tolerance which may degrade at lower temperatures are protected to prevent degradation. Examples of low heat tolerance materials include awnings, vinyl siding, fabrics, some plastics, filmy materials, etc.

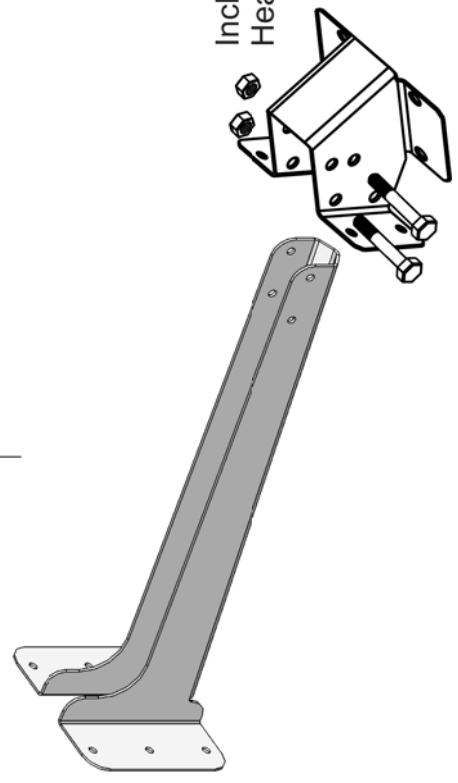
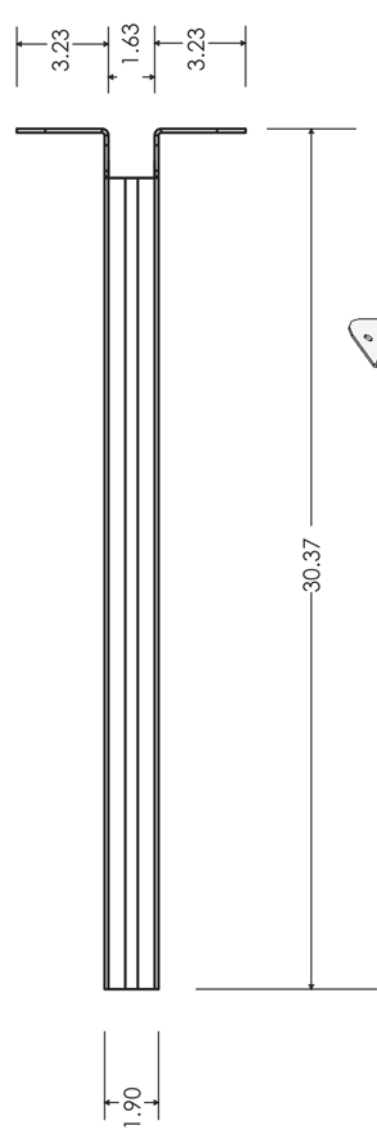
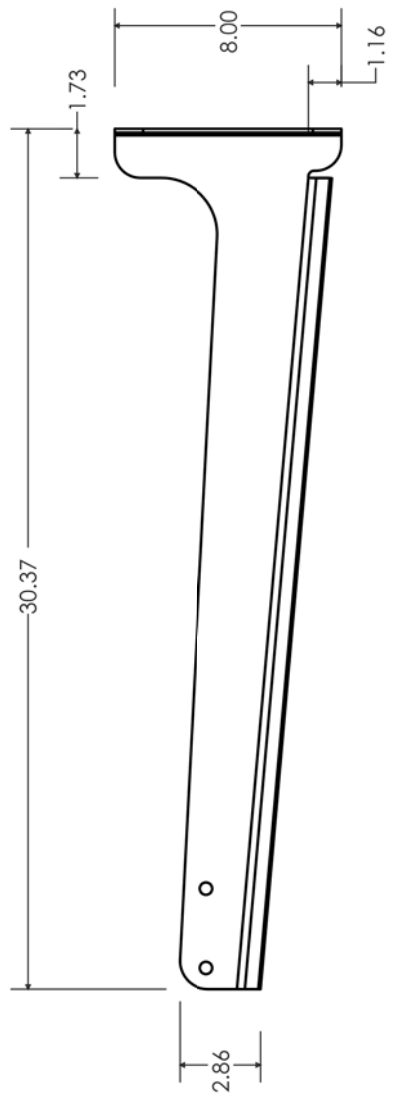
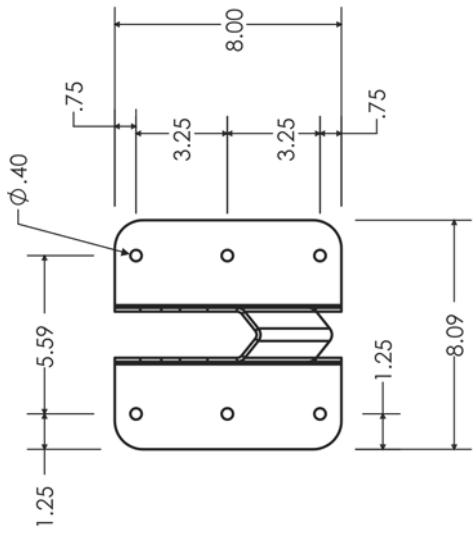

Includes  
Heater Mounting Bracket

**OPTIONAL MOUNTING ARM JP-2300-MK - 2100 SERIES**

**bistroSchwank 2100 SERIES COMPONENT DESCRIPTION**

<b>2135 &amp; 2150 SINGLE-STAGE CONTROL</b>		PATIO CONTROL PANEL 24 VOLT
		WIRELESS REMOTE CONTROL
		ThermoControl Plus:      TC+1                      TC+2                      TC+4
<b>2152 2-STAGE CONTROL</b>		JM-0201-TS Single Switch Gang 2-Stage Control - 1 Zone - 1 to 4 Heaters
		JM-0202-TS Double Switch Gang 2-Stage Control - 2 Zones - 2 to 8 Heaters
		JM-0203-TS Triple Switch Gang 2-Stage Control - 3 Zones - 3 to 12 Heaters
<b>IGNITION</b>		SPARK IGNITED PILOT; DIRECT SPARK MODULE: 3 TRIAL IGNITION SEQUENCE; AUTOMATIC SOFT LOCK-OUT WITH AUTO RESET AFTER 30 MINUTES FOR IGNITION RETRIAL
<b>2135 &amp; 2150 COMBINATION GAS VALVE</b>		SINGLE-STAGE NATURAL GAS: 5" W.C. MANIFOLD PRESSURE
		SINGLE-STAGE PROPANE: 10" W.C. MANIFOLD PRESSURE
<b>2152 COMBINATION GAS VALVE</b>		TWO-STAGE NATURAL GAS ONLY: 5" / 3.0" W.C. MANIFOLD PRESSURE
<b>WIND SCREEN</b>		2135: ALUMINUM EGG-CRATE 2150, 2152: STAINLESS STEEL EGG-CRATE
<b>CABINET</b>		MARINE GRADE 316 STAINLESS STEEL
<b>VENTURI TUBE</b>		ALUMINIZED STEEL ASSEMBLED TO BURNER HOUSING
<b>BURNER</b>		SINGLE ATMOSPHERIC BURNER; 3-TRIAL SPARK IGNITED PILOT WITH SOFT LOCKOUT (30 MINUTE RETRIAL CYCLE); ELECTRONIC FLAME MONITORING / MAINTENANCE SYSTEM
<b>CERAMIC TILE</b>		SCHWANK EFFECT TILE 14/4 WITH SURFACE INDENTATIONS TO INCREASE EMITTING SURFACE AREA, AND HARD FINISHED EDGES
<b>CERAMIC TILE RETAINERS</b>		STAINLESS STEEL
<b>COMBUSTION</b>		TILE SURFACE TEMPERATURE: 1,760°F [960°C] "COLD STATE" COMBUSTION TRANSFERS HEAT INSTANTANEOUSLY TO TILE SURFACE AND MINIMIZES EMISSIONS: CO: 10 – 48 ppm, air free [11 – 50 mg/kWh] NOx: 9 – 14 ppm, air free [15 – 25 mg/kWh]