

Honeywell

THE VR8304 INTERMITTENT PILOT DUAL AUTOMATIC VALVE COMBINATION GAS CONTROLS ARE USED IN GAS-FIRED, INTERMITTENT PILOT APPLIANCES. THE CONTROLS INCLUDE A MANUAL VALVE, TWO AUTOMATIC OPERATORS AND A PRESSURE REGULATOR.

- Used with S86F,H; S860D, S8600F,H and S90A,B Control Modules.
- For use with 24 Vac heating appliances that burn natural or manufactured gas, or liquefied petroleum (LP) gas.
- Capacity rated up to 300 feet³/hour at 1 inch wc pressure drop [8.5 meters³/hour at 0.25 kPa]. Maximum capacity rated up to 415 feet³/hour [11.8 meters³/hour]. Minimum capacity rated at 30 feet³/hour [0.8 meters³/hour].
- Solenoid-operated first automatic valve opens on thermostat call for heat and closes when call for heat ends.
- Diaphragm-operated second automatic valve opens under control of the regulator and closes if gas or power supply is interrupted.
- Two-position gas control knob has ON and OFF positions.
- All adjustments and wiring connections are accessible from top of the control.
- Compact size.
- Straight-through body pattern; right angle adapters available for inlet and outlet.
- Available in 1/2 and 3/4 inch inlet and outlet. 1/2 and 3/4 inch straight and angle flanges available.
- Adjustable servo regulator effectively maintains almost constant gas output pressure under wide fluctuations in gas supply pressure.
- Inlet screen included.
- Pilot filter included.
- Wiring terminal block color-coded orange to indicate intermittent pilot control.
- May be installed at any angle between 0 and 90 degrees from the upright position, including vertically.
- 1/4 inch male quick-connect terminals for electrical connections.
- 40° F to +175° F [-40° C to +79° C] temperature range standard (VR8304H: 0° F to +175° F [-18° C to +79° C]).
- Inlet and outlet pressure taps provided; both taps accessible from top of control.
- Standard, slow, and step-opening models available.
- Natural/LP gas conversion kits available for standard and slow-opening models.

D.T.
Rev. 5-91

Form Number 68-0108—1
© Honeywell Inc. 1991

INTERMITTENT PILOT DUAL AUTOMATIC VALVE COMBINATION GAS CONTROLS

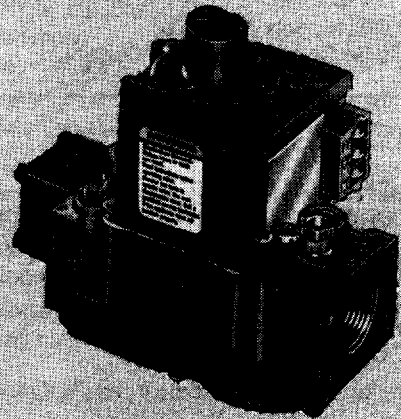

VR8304

SPECIFICATIONS

IMPORTANT

THE SPECIFICATIONS GIVEN IN THIS PUBLICATION DO NOT INCLUDE NORMAL MANUFACTURING TOLERANCES. THEREFORE, THIS UNIT MAY NOT MATCH THE LISTED SPECIFICATIONS EXACTLY. ALSO, THIS PRODUCT IS TESTED AND CALIBRATED UNDER CLOSELY CONTROLLED CONDITIONS, AND SOME MINOR DIFFERENCES IN PERFORMANCE CAN BE EXPECTED IF THOSE CONDITIONS ARE CHANGED.

SUPER TRADELINE MODELS

SUPER TRADELINE controls offer features not available on TRADELINE or standard models and are designed to replace a wide range of Honeywell and competitive controls.

SUPER TRADELINE Models Available:
VR8304M Combination Gas Control
3/4 inch inlet x 3/4 inch outlet

Additional Features:

- 393691 Natural to LP gas conversion kit
- Two 1/2 x 3/4 inch reducer bushings
- One Q340 Thermocouple (36 inch lead length)
- SUPER TRADELINE packaging with cross reference label and special instruction sheet

TRADELINE MODELS

TRADELINE controls offer features not available on standard models and are designed to replace a wide range of Honeywell and competitive controls.

TRADELINE Models Available:
VR8304M Combination Gas Control

Additional Features:

- 393691 Natural to LP gas conversion kit (not available for VR8300C models)
- One 1/2 x 3/4 inch reducer bushings
- TRADELINE packaging with cross reference label and special instructions sheet

STANDARD MODELS

MODELS: VR8304 Dual Automatic Valve Combination Gas Controls for use in Intermittent Pilot Systems with S86F,H; S860D, S8600F,H, and S90A,B modules. See Table 1 for model specifications.

SUPPLY VOLTAGE: 24 Vac, 50/60 Hz.

CURRENT DRAW: 0.7 A.

ELECTRICAL CONNECTIONS: 1/4 inch male quick-connects. Terminal block color-coded orange.

TYPE OF GAS: Separate models available for natural or LP gas. Natural/LP gas conversion kits are available for standard- and slow-opening models. See Accessories.

(continued on page 3)

ORDERING INFORMATION

WHEN PURCHASING REPLACEMENT AND MODERNIZATION PRODUCTS FROM YOUR WHOLESALER OR YOUR DISTRIBUTOR, REFER TO THE PRICE SHEETS FOR COMPLETE ORDERING NUMBER, OR SPECIFY—

1. Order number.
2. Natural or LP gas.
3. Step pressure on VR8304P.
4. Accessories, if desired.
5. Order separately; pilot burner, igniter-sensor, transformer, limit controller, and thermostat or controller as required.

IF YOU HAVE ADDITIONAL QUESTIONS, NEED FURTHER INFORMATION, OR WOULD LIKE TO COMMENT ON OUR PRODUCTS OR SERVICES, PLEASE WRITE OR PHONE:

1. YOUR LOCAL HONEYWELL RESIDENTIAL AND BUILDING CONTROLS DIVISION SALES OFFICE (CHECK WHITE PAGES OF YOUR PHONE DIRECTORY).
2. RESIDENTIAL AND BUILDING CONTROLS DIVISION CUSTOMER SATISFACTION
HONEYWELL INC., 1885 DOUGLAS DRIVE NORTH
GOLDEN VALLEY, MINNESOTA 55422-4386 (612) 542-7500

IN CANADA—HONEYWELL LIMITED/HONEYWELL LIMITEE, 740 ELLESMERE ROAD, SCARBOROUGH, ONTARIO M1P 2V9. INTERNATIONAL SALES AND SERVICE OFFICES IN ALL PRINCIPAL CITIES OF THE WORLD.

TABLE 1—MODEL SPECIFICATIONS.

MODEL NO. SUFFIX LETTER	OPENING CHARACTERISTIC	TYPE OF GAS	STANDARD FACTORY REGULATOR SETTINGS		RANGES OF OPTIONAL FACTORY REGULATOR SETTINGS		RANGES OF FIELD ADJUSTMENT	
			In. wc	kPa	In. wc	kPa	In. wc	kPa
M	Standard-opening	Natural	3.5	0.9	3 to 5	0.7 to 1.2	3 to 5	0.7 to 1.2
		LP	10.0	2.5	8 to 12	2 to 3	8 to 12	2 to 3
P	Step-opening	Natural	Step—0.7, 0.9, 1.2 or 1.7, as ordered ^a Full Rate—3.5	Step—0.17, 0.22, 0.30 or 0.48, as ordered ^a Full Rate—0.9	Step—0.7, 0.9, 1.2 or 1.7, as ordered ^a Full Rate—3 to 5	Step—0.17, 0.22, 0.30 or 0.48, as ordered ^a Full Rate—0.7 to 1.2	Step—none; Full Rate—3 to 5	Step—none; Full Rate—0.7 to 1.2
		LP	Step—1.4, 2.5, 4.0 or 5.5, as ordered ^a Full Rate—10	Step—0.35, 0.62, 0.99 or 1.37, as ordered ^a Full Rate—2.5	Step—1.4, 2.5, 4.0 or 5.5, as ordered ^a Full Rate—8 to 12	Step—0.35, 0.62, 0.99 or 1.37, as ordered ^a Full Rate—2 to 3	Step—none; Full Rate—8 to 12	Step—none; Full Rate—2 to 3
H	Slow-opening	Natural	3.5	0.9	3 to 5	0.7 to 1.2	3 to 5	0.7 to 1.2
		LP	10.0	2.5	8 to 12	2 to 3	8 to 12	2 to 3

^aStep pressure not adjustable.

CAPACITY:

SIZE (INLET X OUTLET)	CAPACITY AT 1 INCH WC PRESSURE DROP ^a	MINIMUM REGULATED CAPACITY	MAXIMUM REGULATED CAPACITY
1/2 X 1/2	240 feet ³ /hour [6.8 meter ³ /hour]	30 feet ³ /hour [0.8 meter ³ /hour]	340 feet ³ /hour [9.6 meter ³ /hour]
1/2 X 3/4	270 feet ³ /hour [7.6 meter ³ /hour]	30 feet ³ /hour [0.8 meter ³ /hour]	370 feet ³ /hour [10.5 meter ³ /hour]
3/4 X 3/4	300 feet ³ /hour [8.5 meter ³ /hour]	30 feet ³ /hour [0.8 meter ³ /hour]	415 feet ³ /hour [11.8 meter ³ /hour]

^aCapacity based on 1000 btu/feet³, 0.64 specific gravity natural gas at 1 inch wc pressure drop [37.3 MJ/meter³, 0.64 specific gravity natural gas at 0.25 kPa pressure drop.

Use conversion factors in Table 2 to convert capacities for other gasses.

TABLE 2—GAS CAPACITY CONVERSION FACTORS.

GAS	SPECIFIC GRAVITY	MULTIPLY LISTED CAPACITY BY
Manufactured	0.60	0.516
Mixed	0.70	0.765
Propane	1.53	1.62

TABLE 3—FLANGE PART NUMBERS.

INLET/OUTLET PIPE SIZE	FLANGE TYPE	PART NUMBER	
		WITHOUT HEX WRENCH	WITH HEX WRENCH
1/2 inch NPT	Straight	394599-6	393690-16
	Elbow	394599-3	393690-13
3/4 inch NPT	Straight	394599-4	393690-14
	Elbow	394599-5	393690-15

BODY PATTERN: Straight-through body pattern.
 INLET X OUTLET SIZES AVAILABLE: 1/2 x 1/2 inch, 1/2 x 3/4 inch, and 3/4 x 3/4 inch with inlet flange.
 ADAPTERS: Adapters available for 1/2 and 3/4 inch straight and angle connections. Refer to Table 3.

NOTE: Flange Kits include one flange, one O-ring and four mounting screws.

PILOT GAS OUTLET: Compression fitting for 1/4 inch OD tubing.

PRESSURE TAPPING: Inlet and outlet taps standard. Taps accessible from top of gas control. Tap is 1/8 inch NPT with plug containing recess for 3/16 inch. Allen wrench.

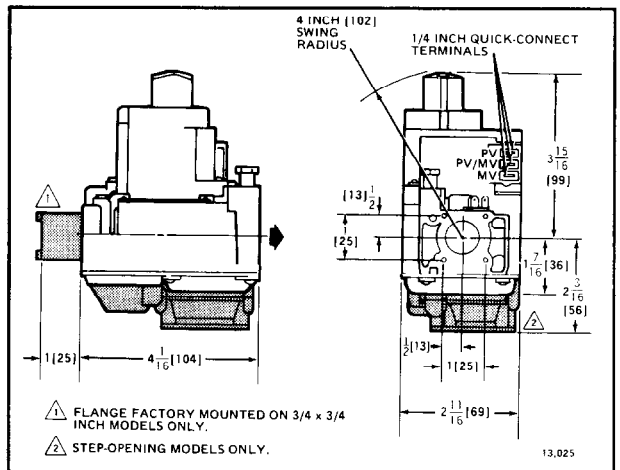

FIG. 1—VR8304 DIMENSIONS IN INCHES AND [MILLIMETERS].

PRESSURE RATING. A.G.A. rating 1/2 psi [3.5 kPa] inlet pressure.

PRESSURE REGULATION: See Table 1. Regulator adjustment accessible from top of gas control.

MOUNTING: Can be mounted 0 to 90 degrees in any direction from the upright position of the gas control knob including vertically.

TEMPERATURE RATING:

VR8304M,P: -40° F to +175° F [-40° C to +79° C].

VR8304H: 0° F to +175° F [-18 C to +79° C].

DIMENSIONS: See Fig. 1.

APPROVALS:

AMERICAN GAS ASSOCIATION DESIGN CERTIFICATE: UP-70-69A.

CANADIAN GAS ASSOCIATION DESIGN CERTIFICATE: UP-70-69A.

AUSTRALIAN GAS ASSOCIATION: Not available.

DELTA C: Not available .

ACCESSORIES:

- Flanges, see Table 3.
- 394349 9/64 inch hex tool for flange assembly screws.
- 393691 Natural to LP gas conversion kit.
- 394588 LP to Natural gas conversion kit.

INSTALLATION

WHEN INSTALLING THIS PRODUCT...

1. Read these instructions carefully. Failure to follow them could damage the product or cause a hazardous condition.
2. Check the ratings given in the instructions and on the product to ensure the product is suitable for your application.
3. Ensure installer is a trained, experienced service technician.
4. After installation is complete, use these instructions to check out product operation.

WARNING

**FIRE OR EXPLOSION HAZARD
CAN CAUSE PROPERTY DAMAGE, SEVERE
INJURY, OR DEATH**

Follow these warnings exactly.

1. **Disconnect power supply before wiring to prevent electrical shock or equipment damage.**
2. **To avoid dangerous accumulation of fuel gas, turn off gas supply at the appliance service valve before starting installation, and perform Gas Leak Test after completion of installation.**
3. **Do not bend pilot tubing at gas control or pilot burner after compression fitting has been tightened, or gas leakage at the connection may result.**
4. **Always install sediment trap in gas supply line to prevent contamination of gas control.**
5. **Do not force the gas control knob. Use only your hand to turn the gas control knob. Never use any tools. If the gas control knob will not operate by hand, the gas control should be replaced by a qualified service technician. Force or attempted repair may result in fire or explosion.**

CAUTION

Never apply a jumper across or short the valve coil terminals. This may burn out the heat anticipator in the thermostat or damage the electronic intermittent pilot (IP) module.

IMPORTANT

These gas controls are shipped with protective seals over inlet and outlet tapings. Do not remove seals until ready to connect piping.

Follow the appliance manufacturer's instructions if available; otherwise, use the instructions provided below.

CONVERTING BETWEEN NATURAL AND LP GAS

WARNING

**FIRE OR EXPLOSION HAZARD
CAN CAUSE PROPERTY DAMAGE, SEVERE
INJURY, OR DEATH**

Do not attempt to use a gas control set for natural gas on LP gas or a gas control set for LP gas on natural gas.

To convert a gas control from natural gas to LP gas or from LP gas to natural gas, contact your Honeywell representative.

Standard- or slow-opening gas controls are converted from one gas to another with a conversion kit (order separately). Order Part Number 393691 to convert from natural to LP gas. Order Part Number 394588 to convert from LP to natural gas. Step-opening gas controls can not be converted.

INSTALL ADAPTERS TO GAS CONTROL

Install adapters to gas control as follows:

Flanges

1. Choose the appropriate flange for your application.
2. Remove seal over gas control inlet or outlet.
3. Ensure the O-ring is fitted in the groove of flange. If the O-ring is not attached or is missing, do not use flange.
4. With O-ring facing gas control, align the screw holes on the gas control with the holes in the flange. Insert and tighten the screws provided with the flange. See Fig. 2. Tighten the screws to 25 inch pounds of torque to provide a gas-tight seal.

Bushings:

1. Remove seal over gas control inlet or outlet.
2. Apply moderate amount of good quality pipe compound to bushing, leaving two end threads bare. On LP installation, use compound resistant to LP gas. Do NOT use Teflon tape.
3. Insert bushing in gas control and thread pipe carefully into bushing until tight.

USING ADAPTERS TO SOLVE SWING RADIUS PROBLEMS

In some field service applications, it is difficult or impossible to thread the gas control onto the gas supply pipe because of space limitations. This problem can be resolved in many instances by using an adapter. The adapter is installed on the end of the supply pipe in place of the gas

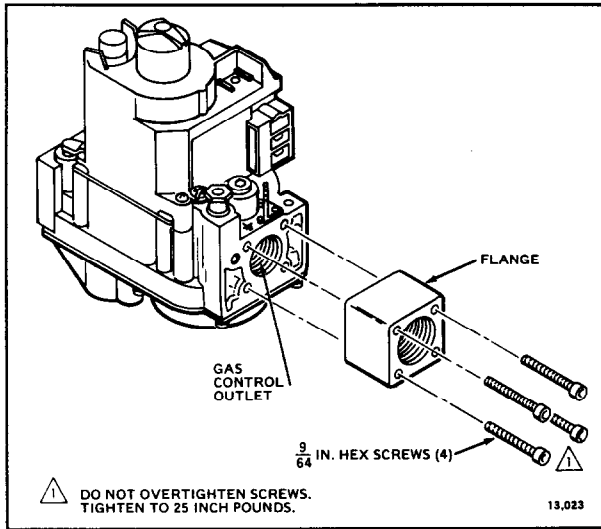

FIG. 2—INSTALL FLANGE TO GAS CONTROL.

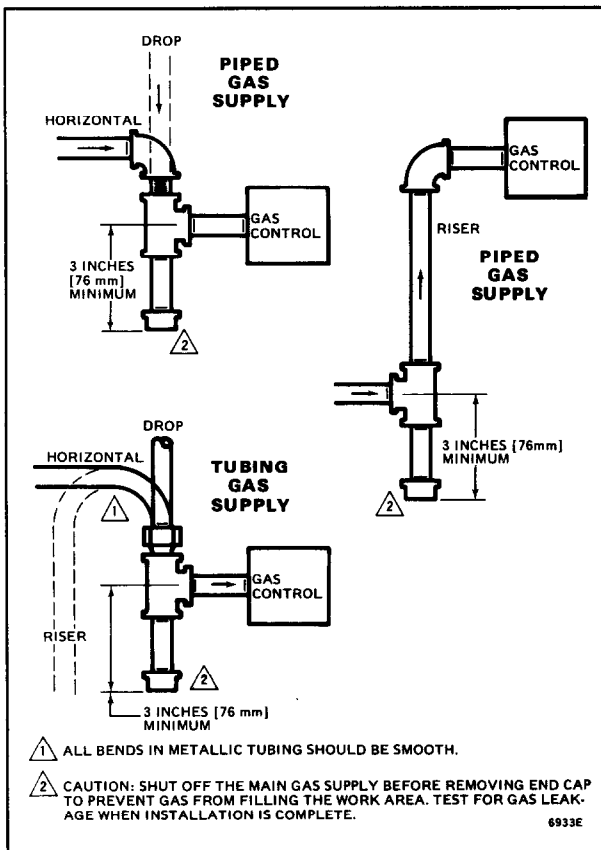

FIG. 3—INSTALL SEDIMENT TRAP.

that are used for installing the gas control. After the adapter is installed, the gas control is attached to the adapter as outlined above. Note that using an adapter increases the overall length of the gas control.

CHOOSE GAS CONTROL LOCATION

Do not locate the gas control where it may be affected by steam cleaning, high humidity, dripping water, corrosive chemicals, dust or grease accumulation, or excessive heat. To ensure proper operation, follow these guidelines.

- Locate gas control in a well ventilated area.
- Mount gas control high enough above the cabinet bottom to avoid exposure to flooding or splashing

water.

- Ensure the ambient temperature does not exceed the ambient temperature ratings for each component.
- Cover gas control if appliance is cleaned with water, steam, or chemicals or to avoid dust and grease accumulation.
- Avoid locating gas control where exposure to corrosive chemical fumes or dripping water are likely.

Locate the gas control in the appliance vestibule on the gas manifold. In replacement applications, locate the gas control in the same location as the old gas control.

Install Piping to Gas Control

All piping must comply with local codes and ordinances or with the National Fuel Gas Code (ANSI Z223.1 NFPA No. 54), whichever applies. Tubing installation must comply with approved standards and practices.

1. Use new, properly reamed pipe free from chips. If tubing is used, ensure the ends are square, deburred and clean. All tubing bends must be smooth and without deformation.

2. Run pipe or tubing to the gas control. If tubing is used, obtain a tube-to-pipe coupling to connect the tubing to the gas control.

3. Install sediment trap in the supply line to the gas control. See Fig. 3.

Install Gas Control

1. Mount the gas control 0-90 degrees, in any direction, from the upright position of the gas control knob, including vertically.

2. Mount the gas control so gas flow is in the direction of the arrow on the bottom of the gas control.

3. Thread pipe the amount shown in Table 4 for insertion into the gas control or adapter. DO NOT THREAD PIPE TOO FAR. Valve distortion or malfunction may result if the pipe is inserted too deeply into the gas control.

TABLE 4—NPT PIPE THREAD LENGTH IN INCHES.

PIPE SIZE	THREAD PIPE THIS AMOUNT	MAXIMUM DEPTH PIPE CAN BE INSERTED INTO CONTROL
3/8	9/16	3/8
1/2	3/4	1/2
3/4	13/16	3/4

4. Apply a moderate amount of good quality pipe compound (DO NOT use Teflon tape) to pipe only, leaving two end threads bare. On LP installations, use compound resistant to LP gas.

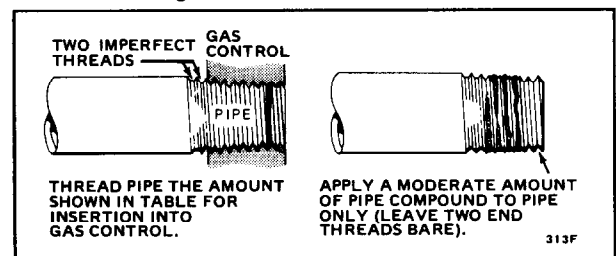

FIG. 4—USE MODERATE AMOUNT OF PIPE COMPOUND.

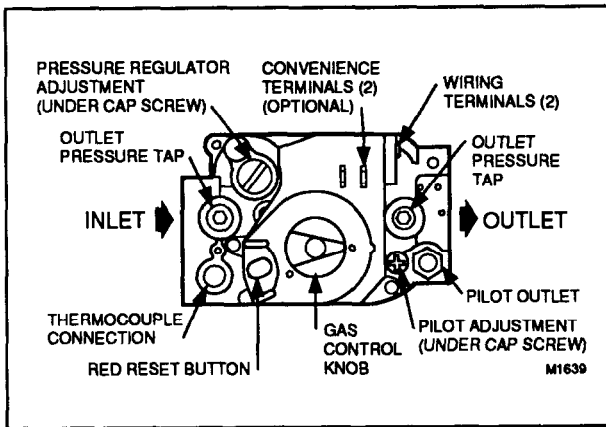

FIG. 5—TOP VIEW OF GAS CONTROL.

Connect Pilot Gas Tubing

1. Cut tubing to desired length and bend as necessary for routing to pilot burner. Do not make sharp bends or deform the tubing. Do not bend tubing at gas control or pilot burner after compression fitting has been tightened, as this may result in gas leakage at the connection.
2. Square off and remove burrs from end of tubing.
3. Unscrew compression fitting from the pilot outlet (Fig. 5). Slip the compression fitting over the tubing and slide out of the way.

NOTE: When replacing a gas control, cut off old compression fitting and replace with the new compression fitting provided on the gas control. Never use the old compression fitting as it may not provide a gas-tight seal.

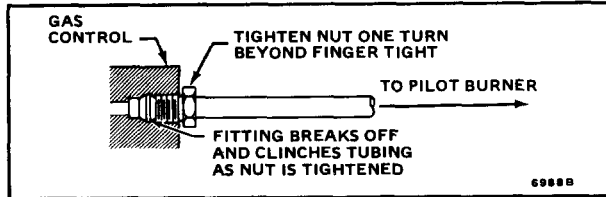

FIG. 7—ALWAYS USE NEW COMPRESSION FITTING.

4. Push tubing into the pilot gas tapping on the outlet end of the control until it bottoms. While holding tubing all the way in, slide compression fitting into place and engage threads—turn until finger tight. Then tighten one more turn with wrench. Do not overtighten. Refer to Fig. 7.

5. Connect other end of tubing to pilot burner according to pilot burner manufacturer's instructions.

WIRING

Follow the wiring instructions furnished by the appliance manufacturer, if available, or use the general instructions provided below.

All wiring must comply with applicable electrical codes and ordinances.

Disconnect power supply before making wiring connections to prevent electrical shock or equipment damage.

1. Check the power supply rating on the gas control and ensure it matches the available supply. Install transformer, thermostat, and other controls as required.

2. Connect control circuit to gas control terminals. See Figs. 5 and 8 or 9.

3. Adjust thermostat heat anticipator to 0.70 rating stamped on valve operator.

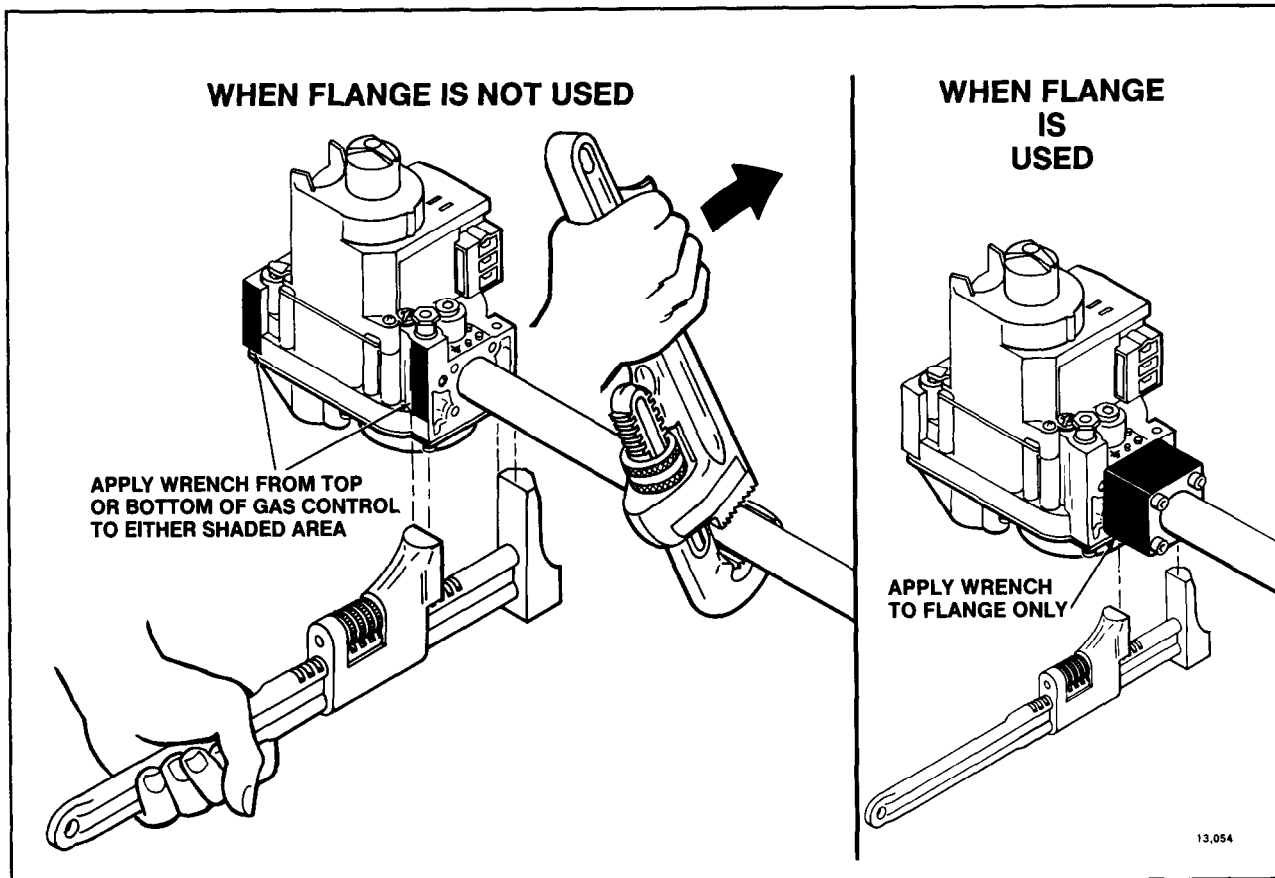

FIG. 6—PROPER USE OF WRENCH ON GAS CONTROL WITH AND WITHOUT FLANGES.

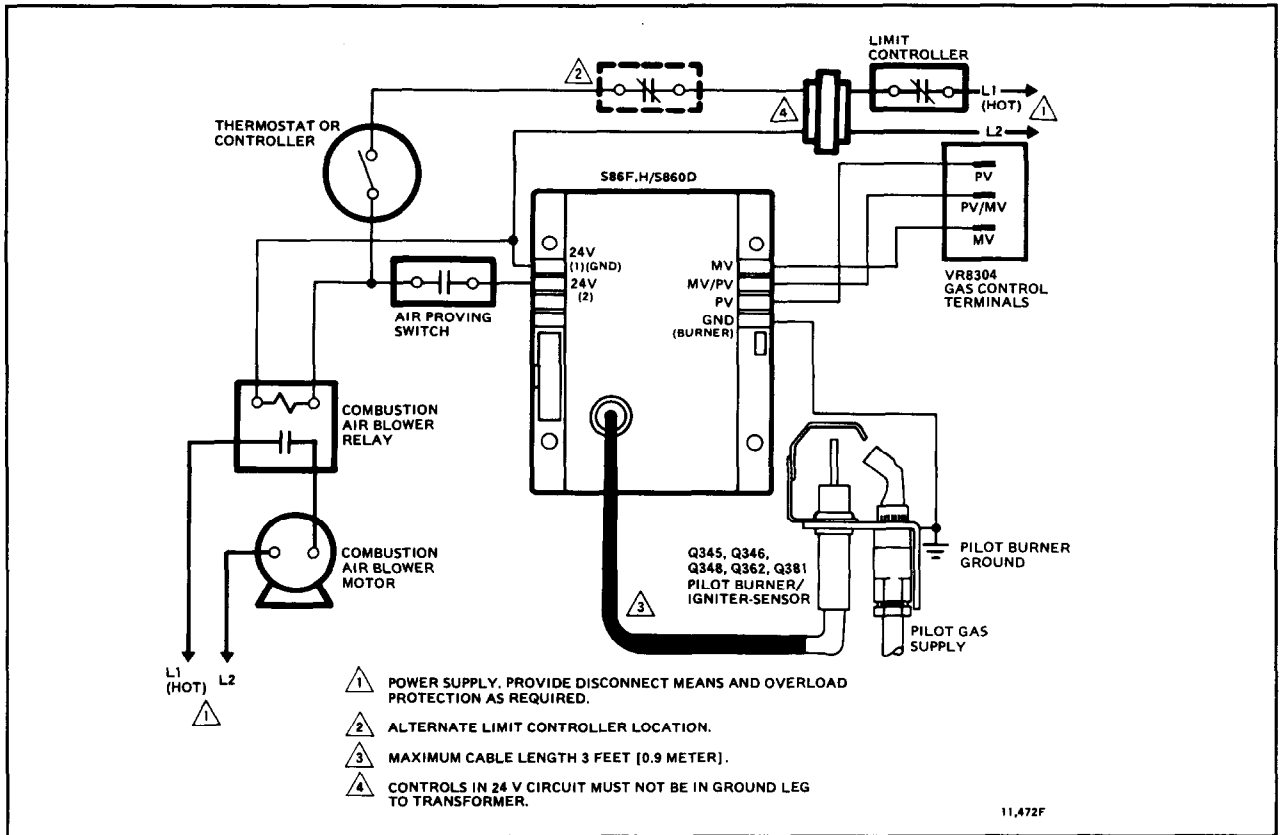

FIG. 8—VR8304 WIRING CONNECTIONS IN INTERMITTENT IGNITION SYSTEM WITH S86.

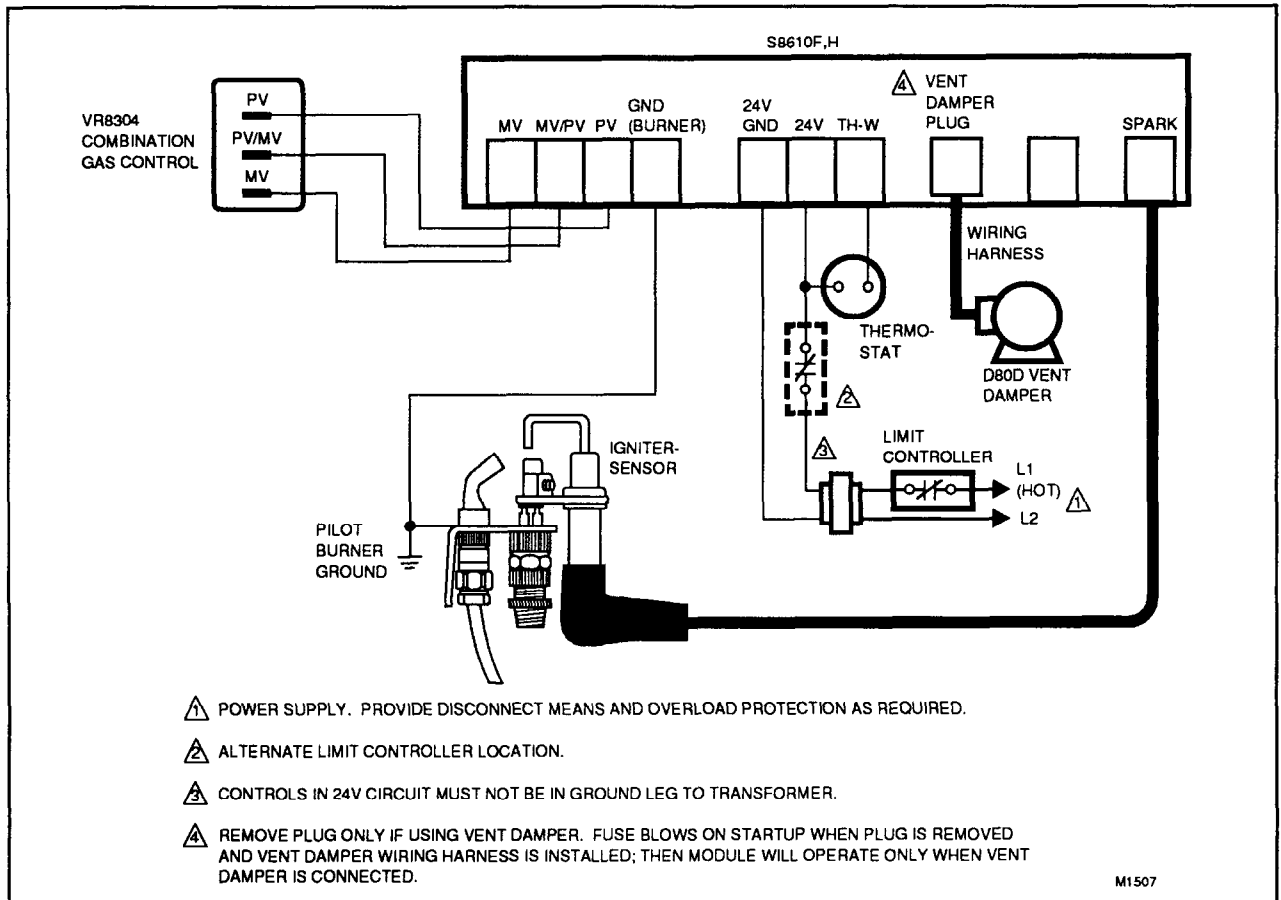

FIG. 9—VR8304 WIRING CONNECTIONS IN INTERMITTENT IGNITION SYSTEM WITH S8600.

START-UP AND CHECKOUT

WARNING

**FIRE OR EXPLOSION HAZARD
CAN CAUSE PROPERTY DAMAGE, SEVERE
INJURY, OR DEATH**

1. Do not force the gas control knob. Use only your hand to turn the gas control knob. Never use any tools.
2. If the gas control knob will not operate by hand, the gas control should be replaced by a qualified service technician.

GAS CONTROL KNOB SETTINGS

The gas control knob has two settings:

- OFF—prevents pilot and main burner gas flow.
- ON—permits gas to flow into the control body. Under control of the thermostat and intermittent pilot module, pilot and main burner gas flow is permitted.

NOTE: Gas controls are shipped with the gas control knob in the ON position.

TURN ON SYSTEM

Rotate the gas control knob counterclockwise ↶ to ON.

TURN ON MAIN BURNER

Follow instructions provided by appliance manufacturer or turn thermostat up to call for heat.

PERFORM GAS LEAK TEST

WARNING

**FIRE OR EXPLOSION HAZARD
CAN CAUSE PROPERTY DAMAGE, SEVERE
INJURY, OR DEATH**

Check for gas leaks with rich soap and water solution any time work is done on a gas control.

GAS LEAK TEST

1. Paint all pipe connections upstream of the gas control with a rich soap and water solution. Bubbles indicate a gas leak.
2. If a gas leak is detected, tighten the pipe connection.
3. Stand clear while lighting main burner to prevent injury caused from hidden gas leaks which could cause flashback in the appliance vestibule. Light the main burner.
4. With the main burner in operation, paint all pipe joints (including adapters) and gas control inlet and outlet with rich soap and water solution.
5. If another gas leak is detected, tighten adapter screws, joints, and pipe connections.
6. Replace the part if gas leak can not be stopped.

ADJUST THE PILOT BURNER FLAME

The pilot flame should envelop 3/8 to 1/2 inch [10 to 13 millimeters] of the igniter-sensor tip. Refer to Fig. 10. To adjust the pilot flame:

1. Remove the pilot adjustment cover screw. Refer to Fig. 5.

2. Turn the inner adjustment screw clockwise ↻ to decrease or counterclockwise ↶ to increase the pilot flame.

3. Always replace the cover screw after adjustment and tighten firmly to ensure proper operation.

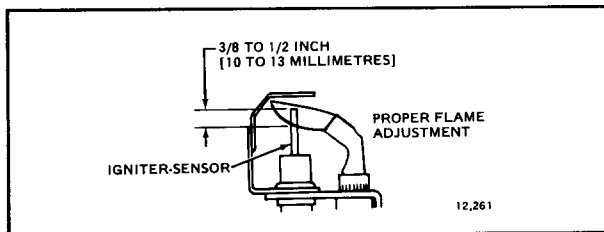

FIG. 10—PROPER FLAME ADJUSTMENT.

CHECK AND ADJUST GAS INPUT TO MAIN BURNER



CAUTION

1. Do not exceed the input rating stamped on the appliance nameplate, or manufacturer's recommended burner orifice pressure for the size orifice(s) used. Ensure the main burner primary air supply is properly adjusted for complete combustion (refer to the appliance manufacturer's instructions).
2. IF CHECKING GAS INPUT BY CLOCKING THE GAS METER:
 - Ensure that the only gas flow through the meter is that of the appliance being tested.
 - Ensure that other appliances are turned off and that their pilot burners are extinguished (or deduct their gas consumptions from the meter reading).
 - Convert the flow rate to Btuh as described in the Gas Controls Handbook (form number 70-2602) and compare to the Btuh input rating on the appliance nameplate.
3. IF CHECKING GAS INPUT WITH A MANOMETER (PRESSURE GAUGE):
 - Ensure the gas control knob is in the PILOT position before removing the outlet pressure tap plug to connect the manometer.
 - Turn the gas control knob back to PILOT when removing the manometer and replacing outlet pressure tap plug.
 - Shut off the gas supply at the appliance service valve or, for LP gas, at the gas tank before removing outlet the pressure tap plug and before disconnecting the manometer and replacing the outlet pressure tap plug.
 - Perform the Gas Leak Test at the inlet pressure tap plug.

Standard-Opening and Slow-Opening Pressure Regulator

1. The gas control outlet pressure should match the manifold pressure listed on the appliance nameplate.
2. With the main burner operating, check the gas control flow rate using the meter clocking method or check the gas pressure using a manometer connected to the gas control outlet pressure tap. Refer to Fig. 5.

3. If necessary, adjust the pressure regulator to match the appliance rating. Refer to Table 5 or 6 for the factory set nominal outlet pressures and adjustment ranges.

- a. Remove the pressure regulator adjustment cap and screw.
- b. Using a screwdriver, turn the inner adjustment screw clockwise  to increase or counterclockwise  to decrease the main burner gas pressure.
- c. Always replace the cap screw and tighten firmly to ensure proper operation.

4. If the desired outlet gas pressure or gas flow rate cannot be achieved by adjusting the gas control, check the gas control inlet pressure using a manometer at the inlet pressure tap. If the inlet pressure is in the normal range (refer to Table 5 or 6), replace the gas control. Otherwise, take the necessary steps to provide proper gas pressure to the gas control.



Step-Opening Pressure Regulator

1. The gas control outlet pressure should match the manifold pressure listed on the appliance nameplate.

2. With main burner operating, check the gas control flow rate using the meter clocking method or check the gas pressure using a manometer connected to the gas

control outlet pressure tap. Refer to Fig. 5.

3. If necessary, adjust the pressure regulator to match the appliance rating. Refer to Table 5 or 6 for factory set nominal outlet pressures and adjustment ranges.

- a. Remove the pressure regulator adjustment cap screw.
- b. Using a screwdriver, turn the inner adjustment screw clockwise  to increase or counterclockwise  to decrease the main burner gas pressure.
- c. Always replace the cap screw and tighten firmly to ensure proper operation.

4. If desired outlet pressure or flow rate cannot be achieved by adjusting the gas control, check the inlet pressure using a manometer at inlet pressure tap or upstream of the gas control. If the inlet pressure is in the normal range (refer to Table 5 or 6), replace the existing gas control. Otherwise, take the necessary steps to provide proper gas pressure to the gas control.

5. Carefully check main burner lightoff at the step pressure. Ensure the main burner lights smoothly and without flashback to the orifice and that all ports remain lit. Cycle the main burner several times, allowing at least 30 seconds between cycles for the regulator to resume the step function. Repeat after allowing main burner to cool. Readjust the full rate outlet pressure if necessary to improve lightoff characteristics.

TABLE 5—PRESSURE REGULATOR SPECIFICATION PRESSURES IN INCHES WC.

MODEL	TYPE OF GAS	NOMINAL INLET PRESSURE RANGE	OUTLET PRESSURE			
			NOMINAL FACTORY SETTING		SETTING RANGE	
			STEP	FULL RATE	STEP	FULL RATE
Standard, Slow-opening	NATURAL LP	5.0 - 7.0 12.0 - 14.0	—	3.5	—	3.0 - 5.0
			—	11.0	—	8.0 - 12.0
Step-opening	NATURAL LP	5.0 - 7.0 12.0 - 14.0	0.9	3.5	—	3.0 - 5.0
			2.2	11.0	—	8.0 - 12.0

TABLE 6—PRESSURE REGULATOR SPECIFICATION PRESSURES IN kPa.

MODEL	TYPE OF GAS	NOMINAL INLET PRESSURE RANGE	OUTLET PRESSURE			
			NOMINAL FACTORY SETTING		SETTING RANGE	
			STEP	FULL RATE	STEP	FULL RATE
Standard, Slow-opening	NATURAL LP	1.2 - 1.7 2.9 - 3.9	—	0.9	—	0.7 - 1.2
			—	2.7	—	2.0 - 3.0
Step-opening	NATURAL LP	1.2 - 1.7 2.9 - 3.9	0.2	0.9	—	0.7 - 1.2
			0.9	2.7	—	2.0 - 3.0

CHECK SAFETY SHUTDOWN PERFORMANCE

WARNING

**FIRE OR EXPLOSION HAZARD
CAN CAUSE PROPERTY DAMAGE, SEVERE
INJURY, OR DEATH**
Perform the safety shutdown test any time work
is done on a gas system.

NOTE: Read steps 1-7 below before starting and compare to the safety shutdown or safety lockout tests recommended for the intermittent pilot (IP) module. Where they differ, use the procedure recommended for the module.

1. Turn gas supply off.
2. Set thermostat or controller above room temperature to call for heat.
3. Watch for spark at pilot burner either immediately or following prepurge. See IP module specifications.
4. If module has timed ignition, time length of spark operation. See IP module specifications.
5. After the module locks out, open gas control knob and ensure there is no pilot or main burner gas flow. *With modules that continue spark until pilot lights or system is shut down manually, pilot should light when gas control knob is opened.*
6. Set thermostat below room temperature and wait one minute.
7. Operate system through one complete cycle to ensure all controls operate properly.

MAINTENANCE

WARNING

**FIRE OR EXPLOSION HAZARD
CAN CAUSE PROPERTY DAMAGE, SEVERE
INJURY, OR DEATH**
Improper cleaning or reassembly may cause gas
leakage. When cleaning, ensure that control is
reassembled properly and perform gas leak test.

Regular preventive maintenance is important in applications that place a heavy load on system controls, such as in the commercial cooking and agricultural and industrial industries because:

- In many such applications, particularly commercial cooking, the equipment operates 100,000 to 200,000 cycles per year. Such heavy cycling can wear out the gas control in one to two years.
- Exposure to water, dirt, chemicals and heat can damage the gas control and shut down the control system.

The maintenance program should include regular

checkout of the gas control as outlined under STARTUP AND CHECKOUT on page 8, and the control system as described in the appliance manufacturer's literature.

Maintenance frequency must be determined individually for each application. Some considerations are:

- *Cycling frequency.* Appliances that may cycle 100,000 times annually should be checked monthly.
- *Intermittent use.* Appliances that are used seasonally should be checked before shutdown and again before the next use.
- *Consequence of unexpected shutdown.* Where the cost of an unexpected shutdown would be high, the system should be checked more often.
- *Dusty, wet, or corrosive environment.* Since these environments can cause the gas control to deteriorate more rapidly, the system should be checked more often.

The gas control should be replaced if:

- It does not perform properly on checkout or troubleshooting.
- The gas control knob is hard to turn or push down, or it fails to pop back up when released.
- The gas control is likely to have operated for more than 200,000 cycles.

OPERATION

The VR8300 gas controls provide ON-OFF manual control of gas flow. In the OFF position, pilot and main burner gas flow is prevented. In the ON position, pilot and main burner gas flow is under control of the thermostat, the intermittent pilot module, and the two automatic main valves.

SYSTEM OPERATION WITH S8600

When the thermostat calls for heat, the S8600 Intermittent Pilot Module is energized. The S8600, in turn, activates the first automatic valve of the gas control. Pilot gas flow is allowed. Simultaneously, the S8600 module generates a spark at the igniter-sensor and lights the pilot. The pilot flame is sensed by the igniter-sensor, and spark generation ends.

After the pilot is lit, the S8600 module energizes the solenoid for the second automatic valve operator and gas flow main burner is followed (the first automatic valve remains energized). The second automatic valve dia-

phragm, controlled by the servo pressure regulator, opens and adjusts gas flow as long as the system is powered and the pilot is burning. The servo pressure regulator monitors outlet pressure to provide an even main burner gas flow. Loss of power (thermostat satisfied) de-energizes the S8600 module and closes both automatic valves. The system is ready to return to normal service when power is restored through the thermostat.

Loss of pilot flame, or flame too small to reliably light main burner, closes the second automatic valve operator. The S8600 module then attempts to restart pilot. On S8600 modules with lockout timers, the first automatic valve closes after the lockout period. On S8600 modules without lockout timers, the trial for ignition continues indefinitely and the first automatic valve remains open.

If pilot flame is restarted successfully, main burner is reopened, and gas flows to main burner as described above. Gas control operation is described in more detail below.

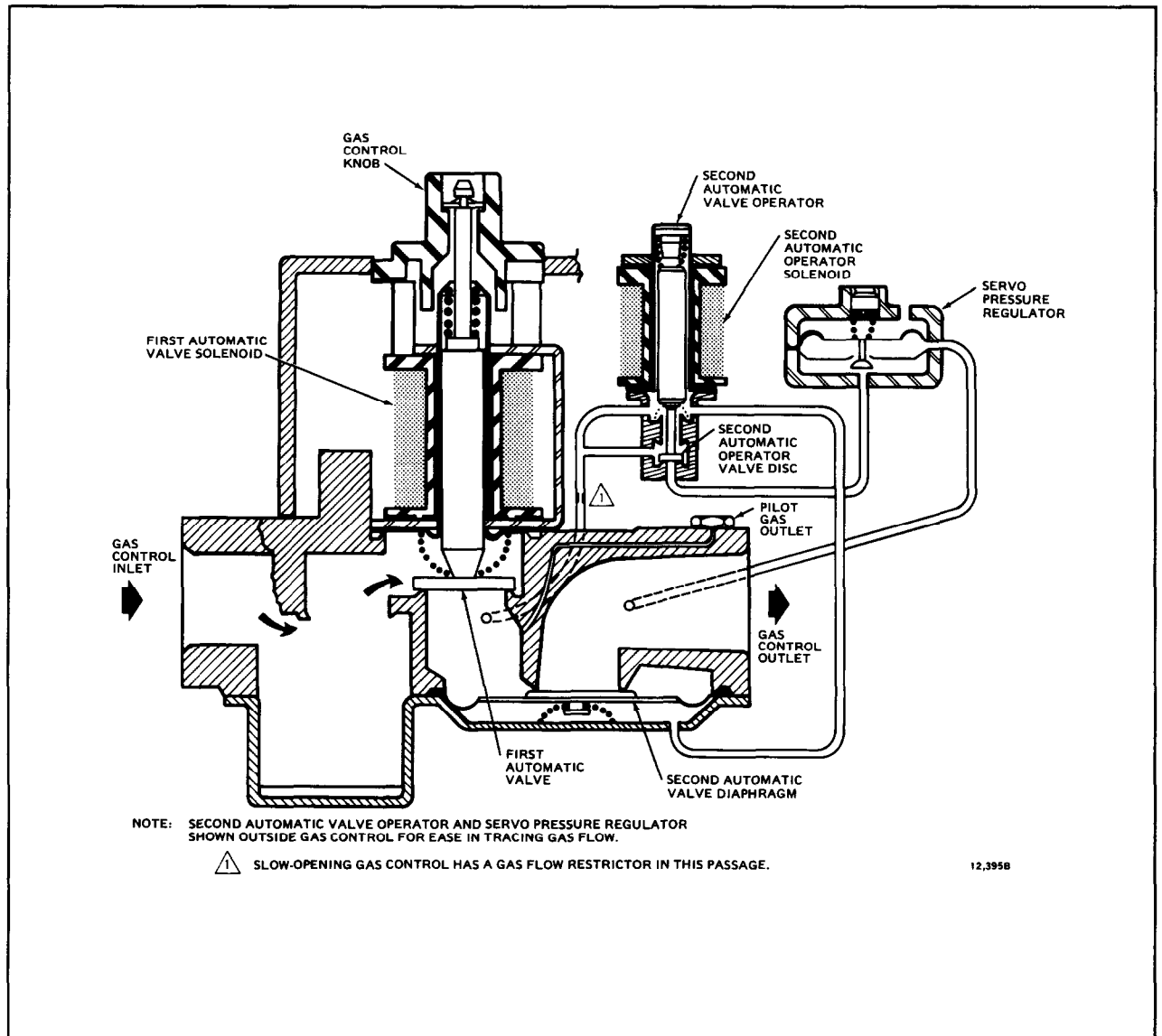

FIG. 11—POSITION OF GAS CONTROL COMPONENTS DURING THERMOSTAT OFF CYCLE.

VALVE POSITION DURING THERMOSTAT OFF CYCLE

The valve is positioned as shown in Fig. 11 when the:

- manual gas control knob is in the ON position.
- thermostat is not calling for heat.

The first automatic valve is closed. The second automatic valve operator is de-energized, closing the channel to the pressure regulator, and opening a channel to the underside of the second automatic valve diaphragm. The combination of spring pressure under the second automatic valve diaphragm and lack of outlet pressure hold the diaphragm firmly closed. Gas pilot burner gas flow is prevented by the first automatic valve and main burner by both valves.

WHEN THERMOSTAT CALLS FOR HEAT

When the thermostat calls for heat, the trial for pilot ignition begins. The first automatic valve solenoid is energized by the module and opens, allowing pilot burner gas flow. Gas also flows to the second automatic valve operator, but is mechanically blocked at the operator. See Fig. 12.

After the pilot lights and the pilot flame is sensed by the igniter-sensor, the second automatic valve solenoid is energized by the module, and the second automatic operator valve disc is lifted off its seat. See Fig. 13. This diverts gas flow from the second automatic valve diaphragm and causes a reduction of pressure on the underside of this diaphragm. The reduced pressure on the bottom of the automatic valve diaphragm repositions the diaphragm downward, away from the valve seat, allowing main burner gas flow.

Standard-Opening Pressure Regulation (VR8304M)

During the ON cycle, the servo pressure regulator provides close control of outlet pressure, even if inlet pressure and flow rate vary widely. Any outlet pressure change is immediately reflected back to the pressure regulator diaphragm, which repositions to change the flow rate through the regulator valve and, thus, through the automatic valve.

If outlet pressure begins to rise, the pressure regulator diaphragm moves slightly higher, allowing less gas flow to the gas control outlet. This increases gas pressure under the automatic valve diaphragm and repositions the valve disc closer to the seat. Thus, flow of gas through the second automatic valve is reduced, and outlet pressure falls to the desired level.

If outlet pressure begins to fall, the pressure regulator diaphragm moves slightly lower allowing more gas flow to the gas control outlet. This decreases gas pressure under the second automatic valve diaphragm and repositions the valve disc further from the seat. Thus, gas flow through the second automatic valve is increased, and outlet pressure rises to the desired level.

Slow-Opening Pressure Regulation (VR8304H)

Slow-opening gas controls function the same as standard-opening models except that when the thermostat calls for heat, the second automatic valve opens gradually.

Opening is slowed because a gas flow restrictor in the passage from the second automatic operator shows the rate at which gas pressure is reduced under the second automatic valve diaphragm after the second automatic

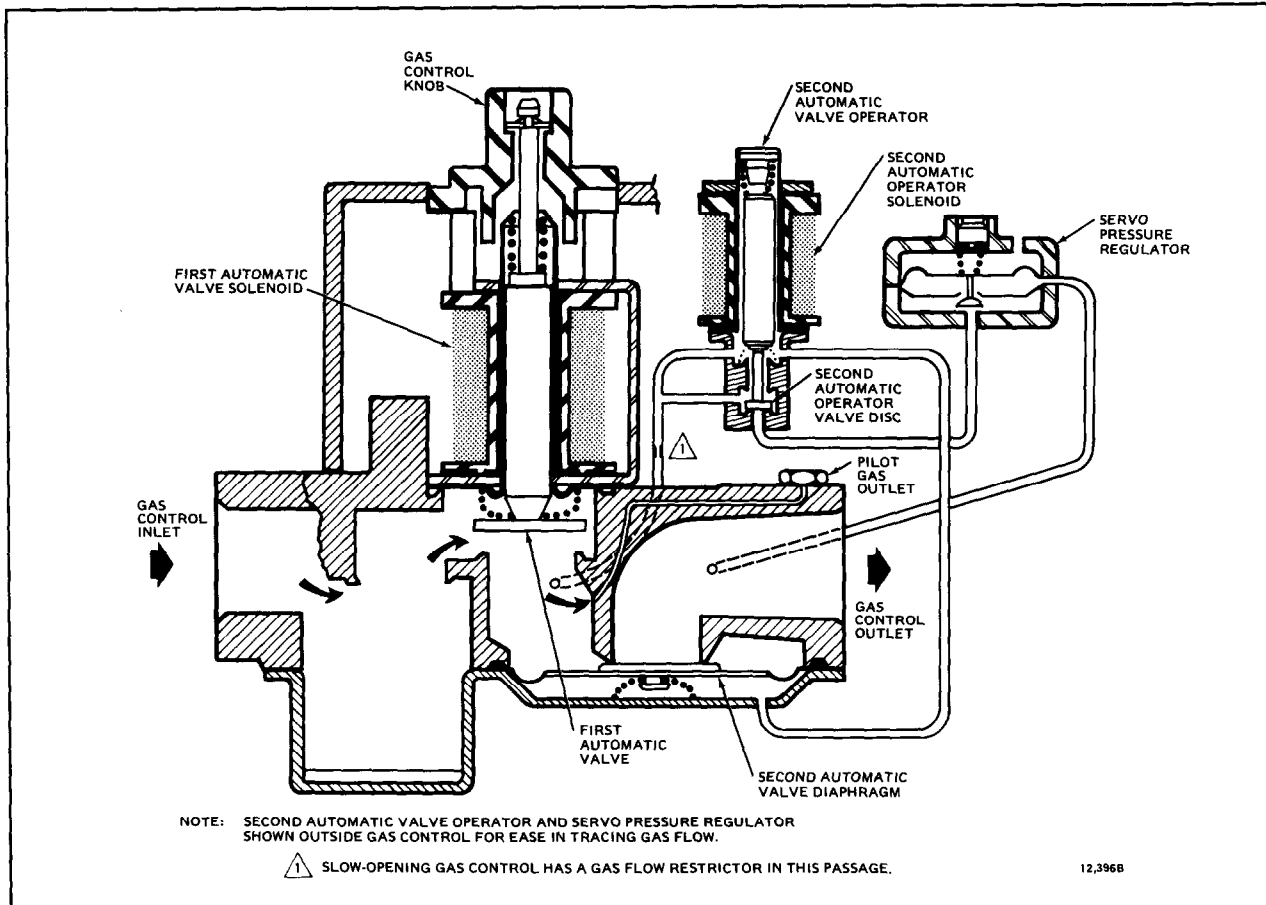

FIG. 12—POSITION OF GAS CONTROL COMPONENTS DURING THE TRIAL FOR PILOT IGNITION.

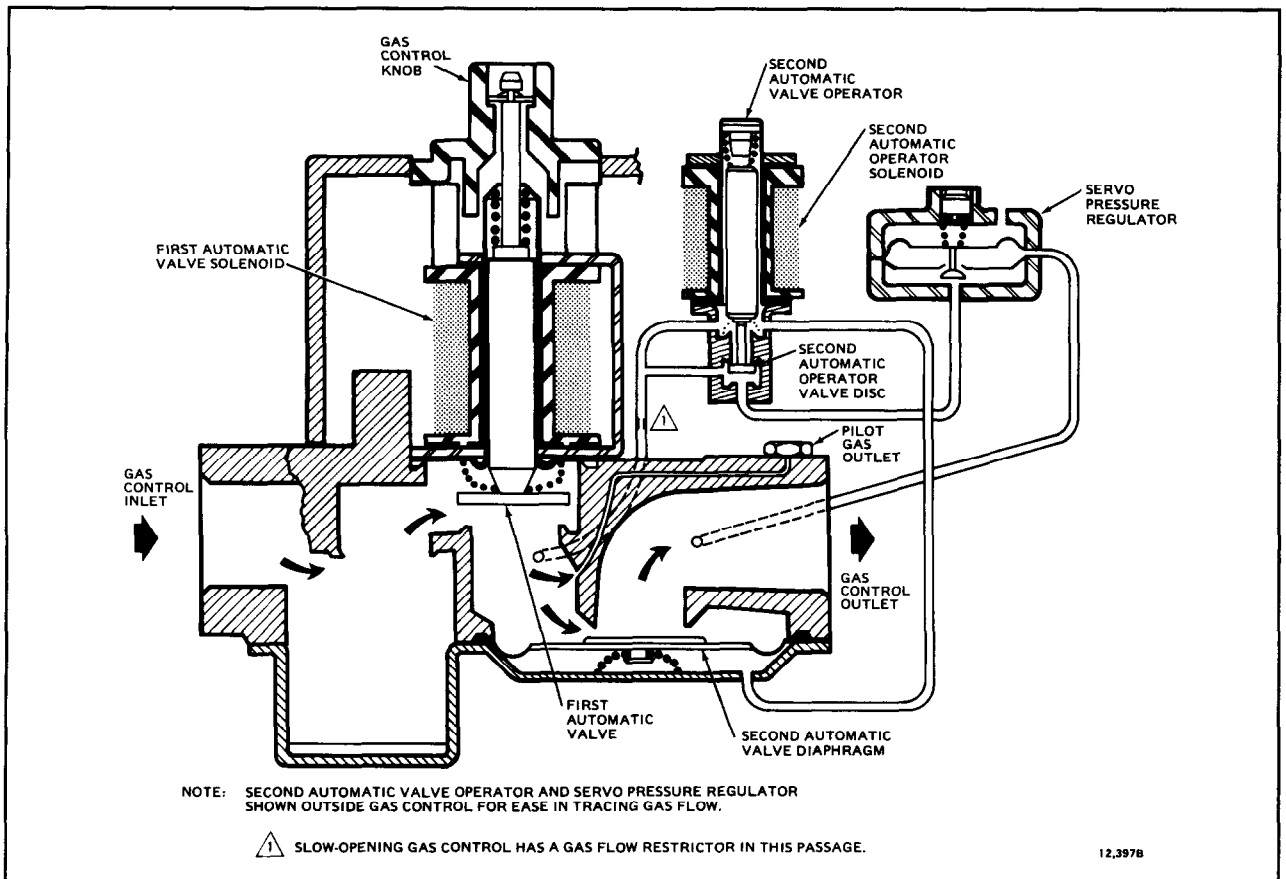

FIG. 13—POSITION OF GAS CONTROL COMPONENTS DURING BURNER ON CYCLE.

operator opens. Outlet pressure to the main burner increases gradually from 0 inches wc [0 kPa] to rated output pressure within 3 to 6 seconds (for an 80,000 Btuh furnace at 7 inches wc [1.8 kPa] inlet pressure and 3.5 inches wc [0.9 kPa] outlet pressure).

Step-Opening Pressure Regulation (VR8304P)

Step-opening gas controls actually combine two pressure regulators, one for the low pressure and one for the full-rate pressure. When the thermostat calls for heat, the automatic operator valve disc opens. The low pressure regulator maintains outlet pressure at the preset step rate for several seconds. Then the regulator valve is forced full open by the timing diaphragm, which is operated by bleed gas. When the low pressure regulator is full open, the high pressure regulator maintains the desired full-rate outlet

pressure as described for the standard regulator.

The step model requires approximately 60 seconds to reset once the main burner goes off. If it is re-energized within 60 seconds, it may bypass or shorten the length of the low pressure step. The burner may relight at the full flow rate.

WHEN THE CALL FOR HEAT ENDS

When the call for heat ends, the first automatic valve and the second automatic valve operator close, bypassing the regulator(s) and shutting off the main burner and the pilot gas flow. As pressure inside the gas control and underneath the automatic valve diaphragm equalizes, spring pressure closes the second automatic valve to provide a second barrier to gas flow.

SERVICE

WARNING

**FIRE OR EXPLOSION HAZARD
CAN CAUSE PROPERTY DAMAGE, SEVERE
INJURY OR DEATH**

**Do not disassemble the gas control; it contains
no replaceable components. Attempted disas-
sembly or repair may damage the gas control.**

CAUTION

**Do not apply a jumper across or short the valve coil
terminals. Doing so may burn out the heat anticipa-
tor in the thermostat or damage the electronic mod-
ule.**

IMPORTANT

**Allow 60 seconds after shutdown before re-energiz-
ing step-opening model to ensure lightoff at step
pressure.**

IF MAIN BURNER WILL NOT COME ON WITH CALL FOR HEAT

1. Ensure the gas control knob is in the ON position.
2. Adjust the thermostat several degrees above room temperature.
3. Using ac voltmeter, check for 24 V at gas control.
 - If pilot lights, measure across MV/PV and MV.
 - If pilot does not light, measure across MV/PV and PV before safety lockout occurs.
4. If voltage is incorrect or not present, check control circuit for proper operation.
5. If 24 V is present, replace gas control.

INSTRUCTIONS TO THE HOMEOWNER

WARNING

FIRE OR EXPLOSION HAZARD CAN CAUSE PROPERTY DAMAGE, SEVERE INJURY, OR DEATH

Follow these warnings exactly:



1. Pilot flame is lit automatically. Do not light the pilot flame manually.
2. Before lighting pilot burner flame, smell around the appliance for gas. Be sure to smell next to floor because LP gas is heavier than air.
3. IF YOU SMELL GAS:
 - Turn off the gas supply at the appliance service valve. On LP gas systems, turn off gas supply at the gas tank.
 - Do not light any appliances in the house.
 - Do not touch electrical switches or use the phone.
 - Leave the building and use a neighbor's phone to call your gas supplier.
 - If you can not reach your gas supplier, call the fire department.
4. Do not force the gas control knob. Use only your hand to push down or turn the gas control knob. Never use any tools. If the gas control knob will not operate by hand, the gas control should be replaced by a qualified service technician. Force or attempted repair may result in a fire or explosion.
5. The gas control must be replaced in case of any physical damage, tampering, bent terminals, missing or broken parts, stripped threads, or evidence of exposure to heat.

IMPORTANT

Follow the operating instructions provided by the manufacturer of your heating appliance. The information below will be of assistance in a typical gas control application, but the specific controls used and the procedures outlined by the manufacturer or your appliance may differ, requiring special instructions.

STOP: READ THE WARNINGS ABOVE.

The pilot flame is lit automatically. If the appliance does not turn on when the thermostat is set several degrees above room temperature, follow these instructions.

1. Set the thermostat to its lowest setting to reset the safety control.
2. Disconnect all electric power to the appliance.
3. Remove the gas control access panel.
4. Push in the gas control knob slightly and turn clockwise  to OFF.
5. Wait five minutes to clear out any unburned gas. If you then smell gas, STOP! Follow Step 3 in the Warnings above. If you do not smell gas, continue with the next step.
6. Turn the gas control knob counterclockwise  to PILOT.
7. Turn the gas control knob counterclockwise  to ON.
8. Replace the gas control access panel.
9. Reconnect all electric power to the appliance.
10. Set the thermostat to the desired setting.
11. If the appliance does not turn on, set the gas control knob to OFF and contact a qualified service technician for assistance.

TURNING OFF THE APPLIANCE

VACATION SHUTDOWN—Set the thermostat to the desired room temperature while you are away.

COMPLETE SHUTDOWN—Push the gas control knob in slightly and turn clockwise  to OFF. Do not force. Appliance will completely shut off. Follow the Lighting Procedures above to resume normal operation.