

Automatic Round Damper With MSS Spring Return Motor Model: RDS

The RDS series are galvanized steel, single blade dampers compete with a 24 Volt, spring return motor actuator. These dampers are shipped complete and ready for installation. The RDS can be installed in any position in any properly sized duct. All RDS dampers are rated for duct systems less than 1.0" W.C.

Dampers are available in 4" 5", 6", 7", 8", 9", 10", 12", 14", 16", 18" and 20" diameters. Dampers are ordered as RDSdd, using 2 digits for each dimension.

All RDS dampers are typically shipped as Power Close dampers that are powered close and spring returned open. The RDS is also unique in that it can be field converted from powered closed to powered open in less than a couple of minutes. A 24 Volt AC, 50/60 Hz, spring return damper motor, powers the RDS. The motor powers the damper closed and spring returns the damper open for fail-safe operation. Providing power to the damper drives the damper closed. Removing power from the motor allows the motor to spring back to the open position.

The 24 Volt, hysteresis, synchronous motor has been tested to over 250,000 cycles to provide long life. Even replacing the motor is a simple less than one (1) minute change by loosening the setscrew holding the motor onto the damper.

The RDS motor also has a simple adjustment for setting the damper to a minimum position. A minimum position allows for excess by-pass air. To set a minimum position, loosen the setscrew, align the setscrew to the minimum position label and re-tighten.

Minimum Position Adjustment

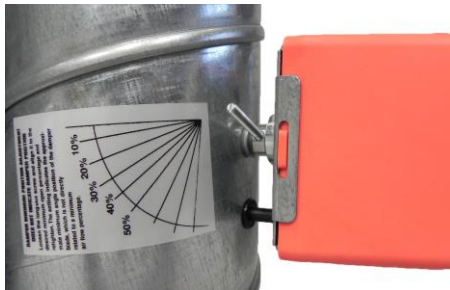

The minimum position screw can also be used to determine the damper position. The setscrew is aligned with the position of the damper blades. When the setscrew is in line with the duct, pointed at the Closed on the minimum position label, the damper is actually open. When it is hidden behind the motor and stopped against the anti-rotation post on the motor, it is Closed or at the minimum adjustment position.

Note: Damper minimum position adjustment does not indicate damper position.



Dimensional Drawing

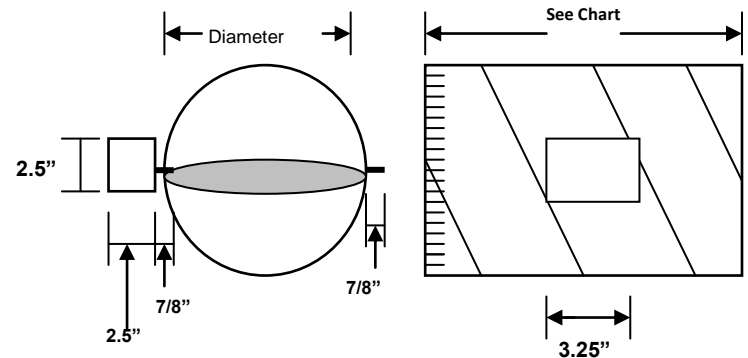

All Dimensions are nominal. Dampers 10" diameter and less are 9.750" in length. Dampers 12" over are .250" shorter in length than the diameter.

Damper Specifications

Construction – 24 Ga. Galvanized Steel (4"-8")

22 Ga. Galvanized Steel (9"-20")

Linkage – Direct Drive

Sizes – 4", 5", 6", 7", 8", 9", 10", 12", 14", 16", 18", 20"

Motor Voltage – 24 Volts AC, 50/60 Hz, 6.5 Watts, 7VA

Torque – 35in-oz to 55in-oz

Temperature Rating – 0°F to 150°F Operating, -20°F to 175°F Storage

Humidity – 5% to 95% Non-Condensing

Damper Timing – Nominal 30 Sec. Powered, 8 Sec. Spring Return

Connection: 4" Wire Leads

Duct Pressure – Maximum 1.0" W.C.

Installation

The RDS is used in-line with the duct and can be installed on a take-off or in-line at any point in the duct. It is recommended the damper be installed as close to the air handler as practical.

Place the flat collar end of the damper over the crimped end of the take-off or rigid metal duct. Insert crimped end of round damper into un-crimped end of rigid round duct and secure with sheet metal screws. When using flexible duct, slip duct over end of the round damper and secure with duct straps (not provided).

The drawing below shows a top view of the damper in line of the duct. When mounting is recommended that the motor and blade shaft be horizontal to the ground.

Top View

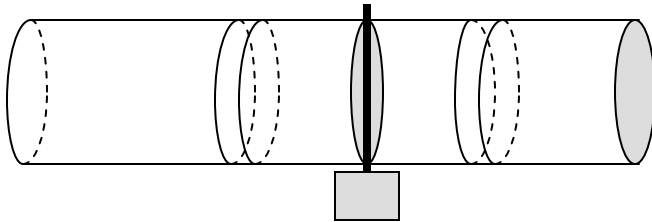

Round damper in-line with round duct.

SideView

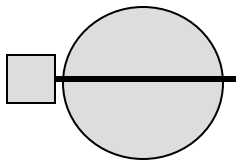

WIRING DIAGRAM

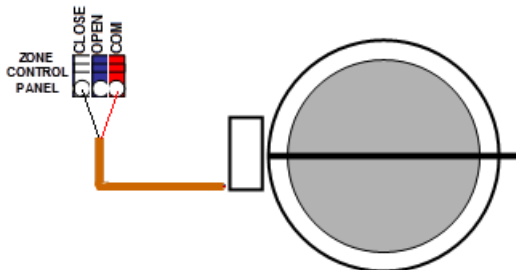
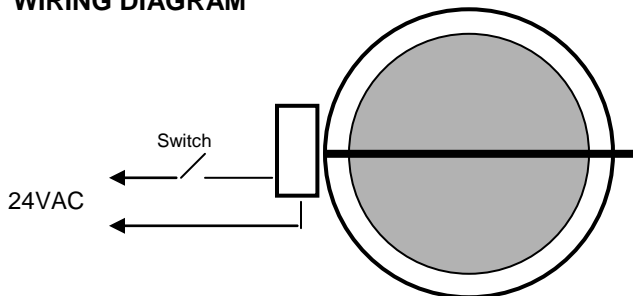

Converting to Powered Opened, Normally Close

All RDS dampers are shipped as Normally Open, Power Close dampers. The RDS can be field converted in less than a minute by the following steps:

- 1) Before applying any power to the damper leave the damper in the normally open position.
- 2) Loosen the set screw and remove motor from the blade shaft.
- 3) Pinch inside of positioning hole grommet and push grommet from hole to remove.
- 4) Push out plastic hole plug on opposite side of damper.
- 5) Switch holes for the grommet and plug.
- 6) Move damper blade to the Close.
- 7) Place motor on opposite side of damper blade shaft and placing the anti-rotation shaft into the hole grommet.
- 8) Tighten the set screw (Make sure the blade is still in the CLOSED position).
- 9) Wire the damper accordingly.
To convert back just reverse this procedure.