



Model
UVD1
In-Duct UVC Air Sanitizer

Project: _____ Engineer: _____
Architect: _____ Location: _____
Contractor: _____ Date: _____
Suppliers: _____



Features

- **Continuous protection** - Kills over 99.9% of viruses, bacteria, and mold in as little as 2 hours*
- **Backed by science** - Proven performance based on third party testing and validation to ASHRAE 185.1 methodology for UV lamps
- **2-year lamp** - Unique 'J' lamp shape is installed parallel to the airflow deactivating more airborne contaminants
- **Convenient installation** - Complete in less than 30 minutes
- **Intensified UVC light** - Innovative aluminum reflector plate increases UV light output for better air treatment
- **Compact design** - Installs in return or supply duct with minimal straight duct needed. Return duct installation is preferred.
- **Certified safe** - Certified OZONE FREE to UL2998 Standard, certified by the California Air Resources Board (CARB), and meets the rigorous standards of ASHRAE 241

Principle of Operation

Installed into the return or supply plenum of a residential HVAC system, the AprilAire lamp design maximizes dwell (contact) time between the air and UVC energy, rapidly purifying the air within the home. For any installation or application questions, please call AprilAire at 800.334.6011.

Application

Foul air is exposed to the UVC 'J' lamp of the UVD1 that is positioned parallel to the airflow, thus maximizing exposure time to UV light. The reflective mirror surface bounces additional UV energy into the plenum. The UV lamp helps reduce the biological contaminants. Finally, the treated air circulates through the home. The unit automatically turns on when the duct frame's safety pin engages the limit switch.

Box Contents

- UVD1 unit
- Reflector
- Duct mounting bracket
- UV lamp
- 6-foot 24 VAC power cord
- Setup & Installation Instructions
- Basic installation kit includes:
 - Cotton gloves
 - Sheet metal screws (4)
 - 6-32 nuts (3)
- Optional accessory (not included) - Plug in Transformer 40VA 24VAC Accessory, Model #8029

*Third party tested using ASHRAE 185.1 methodology against MS-2 (virus), Staphylococcus Aureus (bacteria), Aspergillus Niger (mold). Hours calculation based upon 4 air changes per hour.

Specifications	
Dimensions	6 1/2" W x 11 5/8" H x 3 1/8" D
Shipping weight	2.40 lbs (1.09 kg)
AC voltage	24 VAC, 50/60 Hz
Power	17 Watts
Lamps included	UVD1A
Cable	6 ft wire for 24 VAC connection
Startup & safety	Always ON when plugged in. Limit switch that turns the unit off when dismounted from the frame.
Installation	In the return section (recommended), keep out of range of filters or plastic components.
Display	Display LED indicating status change and countdown to lamp change
Type of lamp	Quartz tube 3/8" (15mm) T5-4 pins
Unit	Aluminum/powder coating paint
Lamp length	6.5"
UVC dosage	0.88 mJ/cm2 (avg) in a 24" x 10" duct of a 2 ton furnace (800 CFM)
Warranty	Ballast: 5 years; Lamp: 2 years; Electronic: 5 years

Technical Drawings

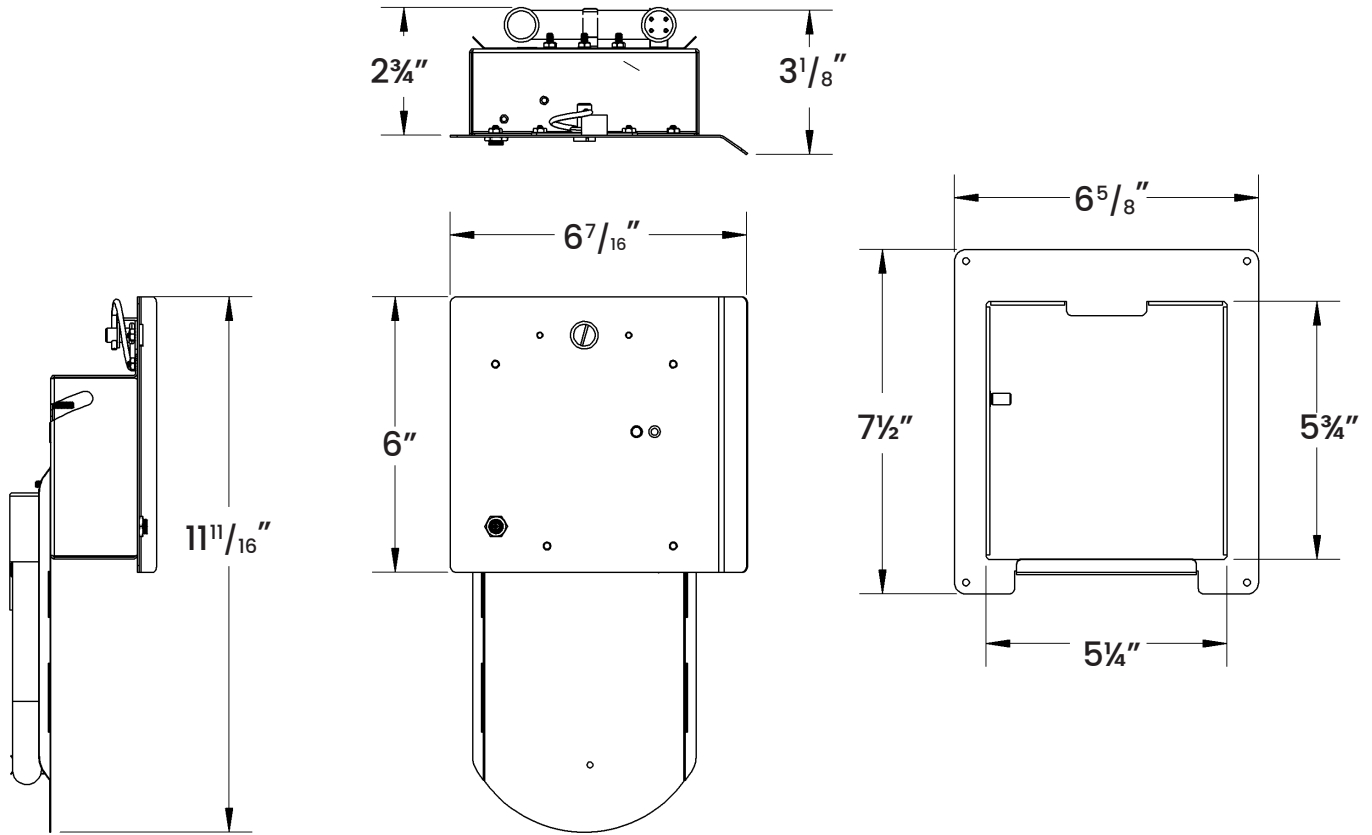

The submittal is intended to show general, overall product dimensions and provide guidance for installation clearance. Drawings are not to scale. Ensure submittals are current. AprilAire reserves the right to make product changes without notification or obligation.