

INSTALLATION & START-UP INSTRUCTIONS

GENERAL

1. Inspect compressor for shipping damage and file claim with shipping company if damaged or incomplete.
2. Check compressor nameplate for correct model and voltage designation.
3. The Carlyle Compound Cooling™ (C³) compressor is a unique design that offers higher capacities and efficiencies than are possible in single stage compressors. Carlyle's C³ Application Guidelines (Lit. No. 570-869) should be carefully reviewed by the personnel responsible for the design of the units that these compressors will be installed in. It is important that these guidelines are carefully followed to ensure safe and reliable operation.
4. To facilitate customer installation requirements, the following parts are factory supplied in a separate parts bag located in the compressor terminal box:

PART NUMBER	DESCRIPTION	QUANTITY
06EA500551	JUMPER BAR (2 HOLE)	3
AT14QA241	JAM NUT 3/8	9
06EA502782	JUMPER BAR (3 HOLE)	1
06CC500021	INSTRUCTION SHEET	1
06EA402632	TEE VALVE ASSY.	1

SAFETY INSTRUCTIONS

WARNING: Failure to follow these instructions could result in serious personal injury.

1. Follow recognized safety procedures and practices.
2. Do not remove any compressor bolts or fittings until factory supplied holding charge has been relieved. Exhaust holding charge pressure through mid stage pressure connection (Fig. 2) by removing the connection cap and depressing the internal stem.
3. Do not apply any power to the compressor unless suction and discharge service valves are installed and opened.
4. Do not operate or provide any electrical power to the compressor unless the terminal box cover is in place and secured. Measurement of amps and volts during running conditions must be taken at other points in the power supply.
5. Do not remove terminal box cover until all electrical sources have been disconnected.
6. Follow recommended safety precautions listed on the terminal box cover label before attempting any service work on the compressor.

GENERAL INSTALLATION PROCEDURES

Holding Charge

Compressor is factory supplied with a 5- to 15-pound charge of dry air. This internal pressure must be relieved before attempting to remove any compressor fitting or part.

Relieve holding charge by removing the threaded cap on the interstage pressure connection fitting and depressing the internal schrader-type stem. See Figure 2 for interstage pressure connection fitting location.

Service Valves

Remove valve pads and install factory supplied suction and discharge gaskets and service valves to the compressor. Torque applicable service valve mounting bolts as noted:

Bolt Size	Torque (lb./ft.)
5/16-18	20-25
1/2-13	80-90
5/8-11	90-120

When brazing piping to valve, disassemble valve if possible or wrap in a wet cloth to prevent heat damage.

Oil

1. Check to see that oil level is 1/8 to 3/8 up on compressor sightglass before starting compressor and after 15 to 20 minutes of operation.

CAUTION: Oil levels on 06CC (50 thru 99 CFM) compressors should not be allowed to go above the center of sightglass. High oil levels require excess power and shorten compressor life.

2. To add oil: Relieve internal crankcase pressure, isolate crankcase, and add oil through the oil fill connection. To remove excess oil: Reduce internal crankcase pressure to 2 psig, isolate crankcase, then loosen the oil drain plug allowing oil to seep out past the threads of the plug. See Figures 2 & 3 for connection locations.

CAUTION: With the compressor crankcase under slight pressure, be careful not to remove the drain plug...the entire oil charge could be lost.

CAUTION: Do not charge oil through the suction line or through the compressor suction access fittings. See Figures 1 & 2 for the recommended oil charging port. Adding oil into the suction side of the compressor can cause damage to the suction/discharge valves, pistons, and/or connecting rods.

3. When additional oil or a complete oil charge is required, use only the listed Carlyle approved oils:

IGI Petroleum Ind..... CRYOL-150
 Totaline 150
 Witco..... Suniso 3GS

Use of oil additives is not allowed without written approval from Carlyle Engineering Department.

Do not reuse drained oil or oil that has been exposed to the atmosphere.

Electrical

GENERAL

Consult the wiring diagram located inside the compressor terminal box cover and Fig. 1 shown below for wiring connection locations.

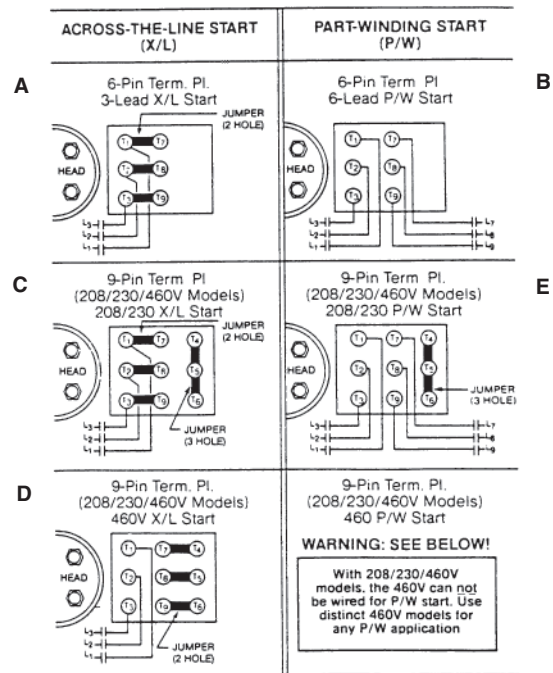

FIGURE 1

Manufacturer reserves the right to discontinue, or change at any time, specifications or designs and prices without notice and without incurring obligations.



06CC COMPRESSOR (50 THRU 99 CFM)

FIGURE 2

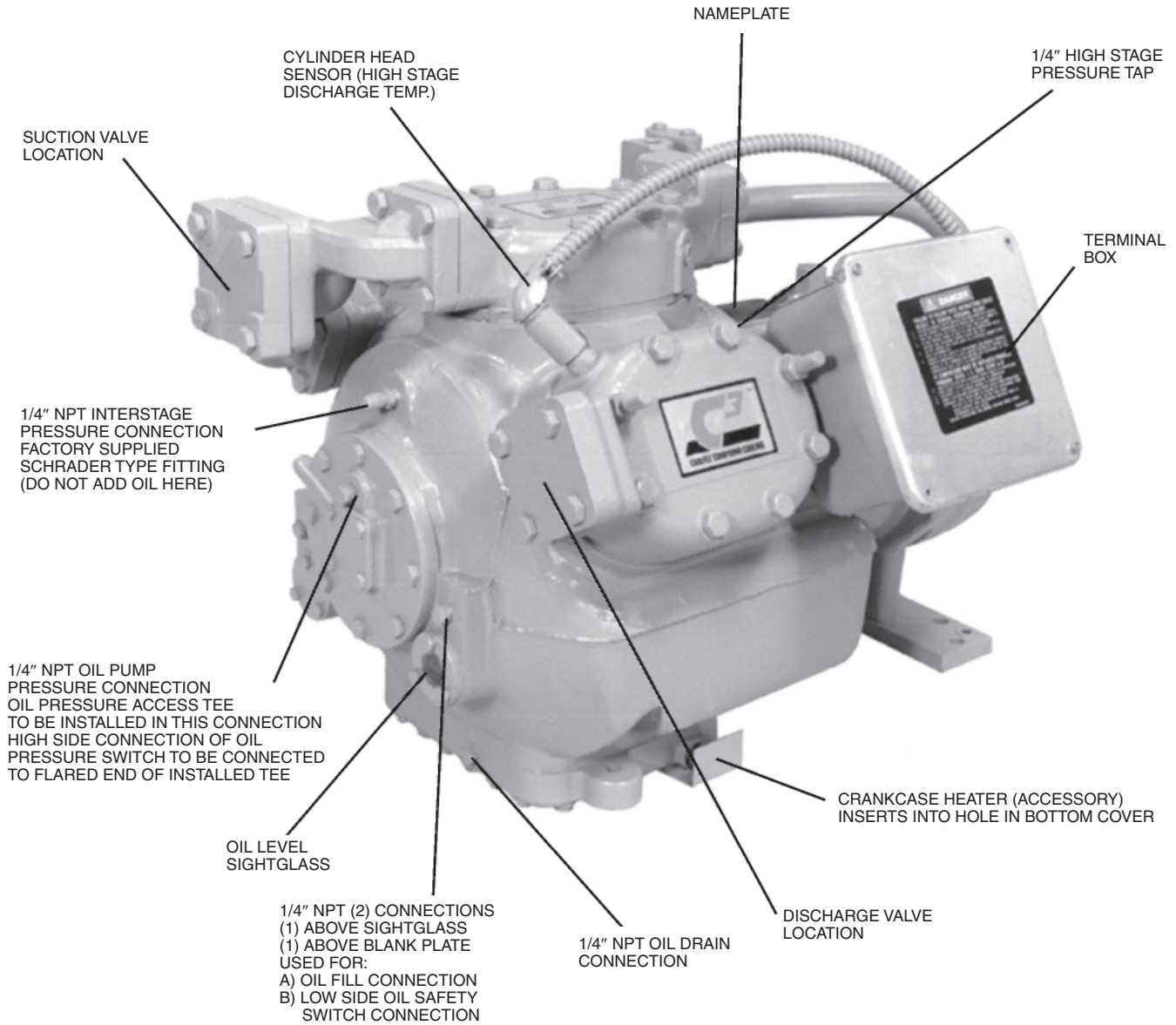
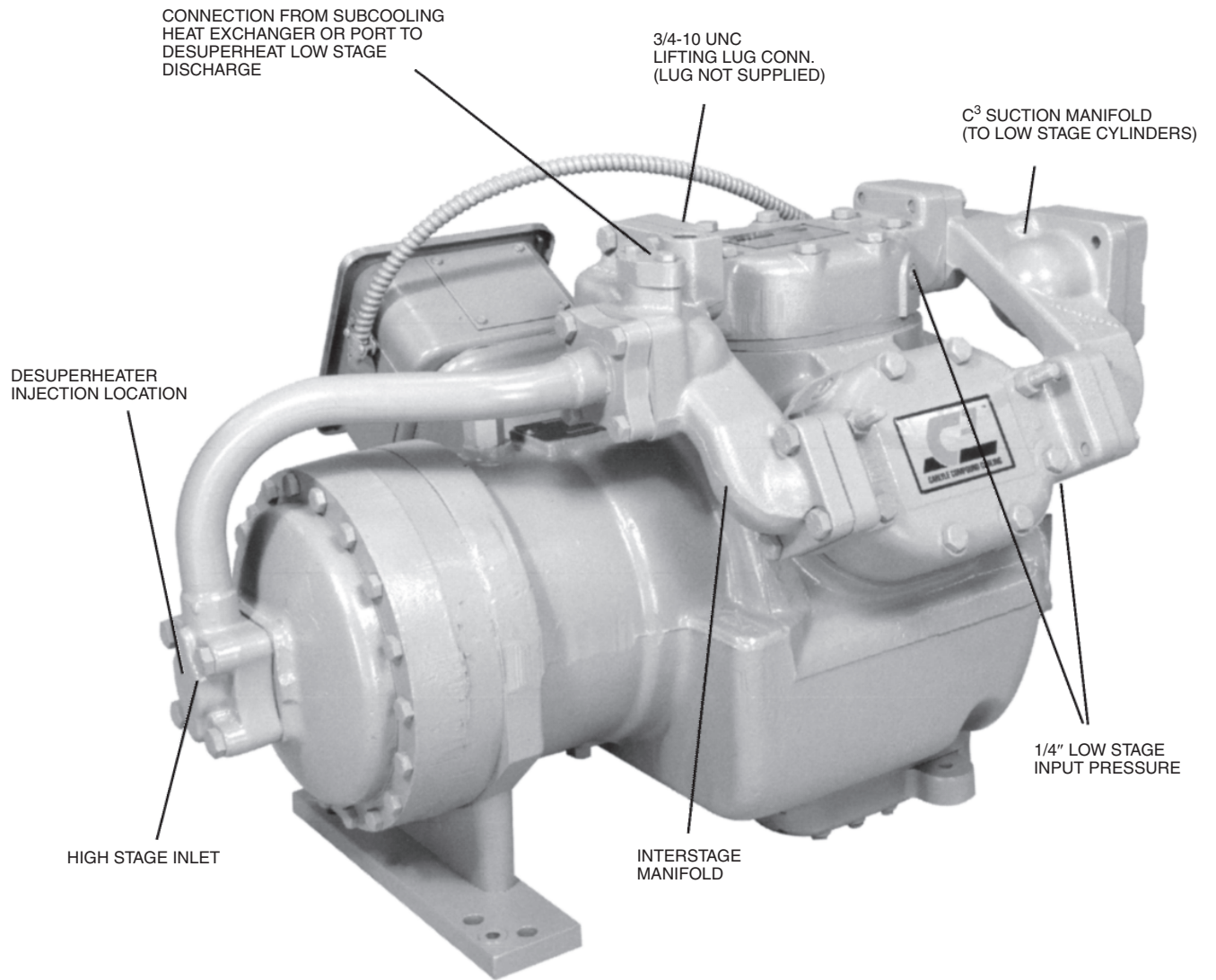

FIGURE 3



TERMINAL BOX

The compressor terminal box is supplied with 2 support plates to mount the connector for the power wiring conduit. Select the one support plate with the opening suitable for the size of the conduit connector to be used and fasten it to the terminal box with the (4) screws provided.

TERMINAL PLATE WIRING FOR 6-PIN TERMINAL

- The parts listed in item #4 (GENERAL COMMENTS, pg. 1) are supplied in parts bag with the compressor and are used when wiring the terminal plate.
- Customer wiring to the compressor terminal plate must be provided with insulated wire terminal connectors and be suitable for accommodating the 3/8" Dia. terminal studs.
- 3-Lead Across-the-Line (X/L) start:

The (3) jumper bars supplied with the compressors are required for 3-Lead XL start only. Jumpers are assembled directly on terminal studs connecting T1 & T7, T2 & T8 and T3 & T9 as shown in (Fig. 1-A).

The 3 power leads are to be assembled to the applicable terminal stud directly on top of the jumper bar. Secure wire terminals and jumper bars to the terminal studs with the (6) 3/8-16 jam nuts provided with the compressor. Torque jam nuts to 12 ft./lbs. maximum.

- 6-Lead Across-the-Line (X/L) or Part Winding (P/W) start (Fig. 1-B):

The 6 power leads are to be assembled and secured to the applicable terminal studs with the (6) 3/8-16 jam nuts provided with the compressor. Torque jam nuts to 12 ft./lbs. maximum.

NOTE: Jumper bars are not required with 6-Lead X/L or P/W start applications.

- For 9-pin terminals for 208/230V-3-60 or 200V-3-50 "Across-the-Line" start applications, connect the jumper bars as follows (Fig. 1-C):
 - Install (3) 2-hole copper jumper bars connecting terminals 1 to 7, 2 to 6, and 3 to 9.
 - Remove plastic connector block from terminals 4, 5 and 6.
 - Install the flat connector block (non-conducting) on terminals 4, 5 and 6.
 - Reinstall terminal nuts on terminals 4, 5 and 6 (removed in Step #2).
 - Install the 3-hole copper jumper bar connecting terminals 4, 5 and 6.
 - Connect the line leads to terminals 1, 2 and 3.
 - Install (9) terminal nuts (included in this kit) on terminal studs to secure jumper bar/line connections. Tighten terminal nuts to 12 ft./lbs. maximum.
- For 9-pin terminals for 208/230V-3-60 or 200V-3-50 "Part Winding" start applications, connect the jumper bars as follows (Fig. 1-D):
 - Remove plastic connector block from terminals 4, 5 and 6.
 - Install the flat connector block (non-conducting) on terminals 4, 5 and 6.
 - Reinstall terminal nuts on terminals 4, 5 and 6 (removed in Step #1).
 - Install the 3-hole copper jumper bar connecting terminals 4, 5 and 6.
 - Connect the line leads to terminals 1, 2, 3, 7, 8 and 9.
 - Install (9) terminal nuts (included in this kit) on terminal studs to secure jumper bar/line connections. Tighten terminal nuts to 12 ft./lbs. maximum.
- For 9-pin terminals for 460V-3-60 or 400V-3-50 "Across-the-Line" start applications, connect the jumper bars as follows (Fig. 1-E):
 - Install (3) 2-hole copper jumper bars connecting terminals 7 to 4, 8 to 5, and 9 to 6.
 - Connect the line leads to terminals 1, 2 and 3.
 - Install (9) terminal nuts (included in this kit) on terminal studs to secure jumper bar/line connections. Tighten terminal nuts to 12 ft./lbs. maximum.

OIL PRESSURE SAFETY SWITCH

- All Carlyle refrigeration-duty 06CC compressors are provided with connections for an oil-safety switch. The use of an oil-safety switch is required as a condition of warranty for 06CC compressors. The oil safety switch can help prevent compressor failures when loss of lubrication or loss of compressor oil charge occur.

- Normal oil pressure for C³ compressors is 12 to 30 psi above interstage pressure (standard pump). The use of a high flow oil pump yields up to 30 psi, depending on model, above interstage pressure. The high flow pumps will allow a minimum oil pressure differential switch time delay of 30 seconds and a maximum time delay of 120 seconds. The switch must be manually reset regardless of the style pump being used.
- The oil-safety switch *high side connection* is to be attached to the oil pressure access tee which is field installed in the oil pump pressure connection as noted below. The *low side connection* of the oil-safety switch is connected to the oil sump compartment of the crankcase. See compressor pictorials (Figures 2 & 3) for proper locations.
- The following oil-safety switches have been specifically approved by Carlyle:

Carlyle & Carrier Part No.	Danfoss Part No.	Time Delay	Connections	Pressure Diff (psi)		Volts	Reset	Remote Alarm Circuit Capability
				Cut In	Cut Out			
634-2008 OR P529-2130	60B2101	45 sec	1/4" Male Flares	8-11	4-8	115/230	Manual	Yes
634-2050 OR P529-2110	60B2151		3/8" Lg. Cap. Tube 1/4" SAE Nuts					
06DA660015 Electronic Oil Switch	N/A	45 sec	Electrical Switch w/o Ext. Tubing	8-11	4-6	115/230	Manual	Yes

OIL PRESSURE ACCESS TEE

- The oil pressure access tee supplied in separate parts bag with the compressor is to be installed in the oil pump pressure connection located at the 12:00 position immediately above the oil pump cover.

CAUTION: Aluminum Bearing Head. Torque oil pressure access tee: 20-25 ft./lbs.

- The oil pressure safety switch *high-side connection* is to be attached to the opened flared end of the installed oil pressure access tee. The capped end of this tee contains schrader-type valve which permits access to the oil pressure while the compressor is operating.

MOTOR PROTECTION

Overcurrent Protection — Customer Supplied

- 06CC compressors are supplied "less" motor overcurrent protection devices. Compressor user *must* provide properly sized overcurrent motor protection. See application manual and price pages for specifications.
- Carlyle recommends the use of calibrated circuit breakers. Circuit breakers based on X/L start with trip settings selected for proper compressor motor size and voltage are available from Carlyle.

Over Temperature Protection — Factory Supplied

- A discharge gas thermal sensor is factory installed in the cylinder head on all new 06CC compressors. The temperature of the discharge gas in the high stage cylinder head is monitored by the thermal sensor. If the discharge gas temperature at the sensor exceeds 295° F, the sensor will open the control circuit and shut off the compressor. The (2) sensor wire leads (#16 AWG, stripped back 1/2"), located in the compressor terminal box are to be connected in series in the unit control circuit wiring. The discharge temperature sensor operates as an automatic re-set device; however, Carlyle recommends that it be wired in the control circuit in a manual re-set mode. Since the cylinder head sensor would help prevent many of the failures caused by overheating, the best control method would be to determine the cause and correct the reason for overheating when the initial sensor trip occurs.



Manufacturer reserves the right to discontinue, or change at any time, specifications or designs and prices without notice and without incurring obligations.

CARLYLE COMPRESSOR CO. • © CARRIER CORPORATION
 P.O. Box 4808, Carrier Parkway, TR-3, Syracuse, New York, 13221
Phone: In U.S. & Puerto Rico: 1-800-GO-CARLYLE (800-462-2759)
 In Canada: 1-800-258-1123
 In Mexico: 001-800-462-2759

Lit. No. 570-850
 Rev. 12/06
 Replaces: 06CC500021