



325 COMMERCE DRIVE
 MT VERNON, OH 43050
 800-253-8236

SPECIFICATION DATA SHEET

DATE: 4-11-13
 PREPARED BY: RL

MODEL NO. 969

OVAL DOUBLE STACKHEAD W/EARS

12" THROAT MODEL

DIMENSIONS

SIZE							
A	x	B	x	C	D	E	F
4"	x	10"	x	6"	4 1/2"	17 5/16"	7 5/8"
4"	x	12"	x	7"	4 1/2"	17 5/16"	9 1/4"

MATERIAL SPECIFICATIONS

HOT DIPPED GALVANIZED STEEL.
 PER ASTM A 653 CSB.
 ASSEMBLED WITH 1/8" ZINC COATED RIVETS.
 STD GAUGE CONSTRUCTION
 BOOT CLIPS ARE STD GAUGE
 EARS ARE STD GAUGE

OPTIONS

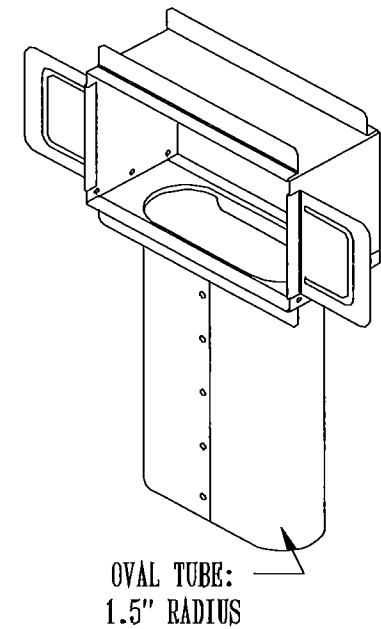
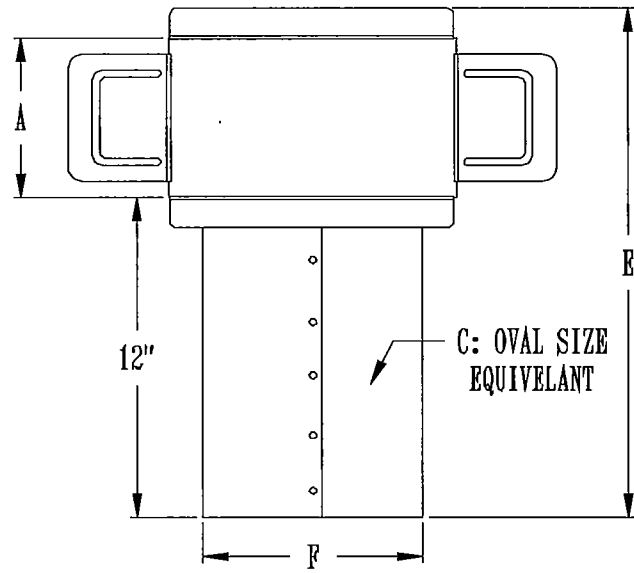
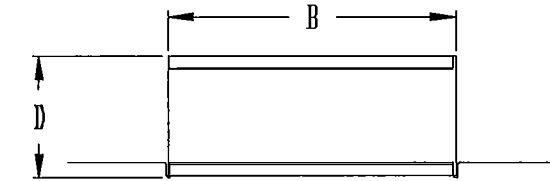

NOTE: EARS ARE SHOWN IN INSTALLATION POSITION.

JOB: _____
 LOCATION: _____
 CONTRACTOR: _____
 ENGINEER: _____
 NOTES: _____