

Tools & Instruments Table of Contents/Part Number Index

DESCRIPTION	PAGE
PART NUMBER INDEX.....	J1A
RECOVERY UNITS.....	J-2 - J-8
RECOVERY ACCESSORIES.....	J-9
PURGING UNITS.....	J-10 - J-11
DUCT STRAP TENSION TOOL.....	J-12
CRIMPING TOOL.....	J-12
WIRE STRIPPERS.....	J-12
ACID / MOISTURE TEST KITS.....	J-12
POCKET THERMOMETERS.....	J-12/ J-18 & J-27
MULTI-METERS.....	J-13 & J-25
CLAMP ON METERS.....	J-14/ J-20 / J-26
MANOMETERS.....	J-15 & J-29
DUAL K DIGITAL THERMOMETERS.....	J-16
NON-CONTACT THERMOMETERS.....	J-17 & J-28
VOLTAGE DETECTORS.....	J-19
REFRIGERANT LEAK DETECTORS.....	J-21 & J-30
GAS LEAK DETECTORS.....	J-22 & J-28
VACUUM GAUGE.....	J-22
VELOCITY METER.....	J-23
DIGITAL TOOL ACCESSORIES.....	J-24
CO2 DETECTOR.....	J-29
INFRARED PRINTER.....	J-30

Compressors,
Chillers, Condensers

Motors

Electrical

Heating
Components

Indoor Air
Quality

Thermostats

Oils &
Chemicals

Accessories, Supplies
& Commodities

Tools &
Instruments

Refrigeration

Tools & Instruments Table of Contents/Part Number Index

PART NUMBER INDEX

PART NO.	PAGE	PART NO.	PAGE	PART NO.	PAGE
120	J-25	A603	J-15	P920-575	J-23
133	J-25	A612	J-15	P920-605	J-22
135	J-25	A700	J-30	P920-620	J-15
153	J-25	A710	J-30	P920-720B	J-22
163	J-25	A712	J-30	P920-750A	J-21
183	J-25	A721	J-30	P920-A080	J-24
255	J-26	A740	J-30	P920-A605	J-24
291	J-26	A755	J-30	P920-A611	J-24
293	J-26	A774	J-15	P920-A774	J-24
296	J-26	C-032-F	J-3	P920-C50	J-19
310	J-27	CARBCAN	J-10	P920-CK20M	J-24
312	J-27	CPK076	J-3	P920-CK21M	J-24
370	J-28	CPK077	J-3	P920-GK13M	J-24
371	J-28	CPK078	J-3	P920-RECOVERY115	J-1
373	J-28	CPK079	J-3	P920-TLS10	J-24
375	J-28	CYL-0250	J-8	P920-V AC4D035	J-3
376	J-28	CYL-0250	J-9	P920-VAC4D015	J-3
377	J-28	CYL-0250-LS	J-9	P920-VAC4D060	J-3
380	J-28	CYL-1000	J-8	RFD154	J-7
381	J-28	CYL-1000	J-9	RGA502	J-3
440	J-27	CYL-1000-LS	J-9	RGA802	J-3
610	J-29	EMS522-011	J-10	RM-050-6	J-9
615	J-29	EMS522-113	J-10	RM-075-6	J-9
620	J-29	EMS522-114	J-10	RSC019	J-3
625	J-29	EMS522-123	J-10	TT1-001	J-12
707	J-29	EMS611-011	J-10	TT1-002	J-12
755	J-30	EMS611-113	J-10	TT2-001	J-12
025-010-HP	J-9	EMS611-114	J-10	TT2-002	J-12
025-010-HP-FB	J-9	EMS611-123	J-10	TT3-001	J-12
025-010-HP-FB	J-11	FD-003-25	J-7		
025-020-HP	J-9	FD-003-25	J-11		
025-020-HP-FB	J-9	FD-030-50	J-8		
025-020-HP-FB	J-11	FD-048-CR	J-5		
038-010-HP	J-9	FVC-006	J-7		
038-010-HP-FB	J-9	FVC-006	J-9		
038-020-HP	J-9	FVC-012	J-9		
038-020-HP-FB	J-9	KIT002	J-4		
050-010-HP	J-9	KIT003	J-4		
050-010-HP-FB	J-8	OIL-POE-1G	J-5		
050-010-HP-FB	J-9	P298- WS	J-12		
050-020-HP	J-9	P298-CT300	J-12		
050-020-HP-FB	J-8	P298-RACT	J-12		
050-020-HP-FB	J-9	P706-0001-L	J-4		
075-010-HP-FB	J-5	P706-0002-L	J-4		
075-010-HP-FB	J-9	P906-1002	J-12		
075-010-HP-QC	J-9	P906-1004	J-12		
075-020-HP-FB	J-5	P906-1006	J-12		
075-020-HP-FB	J-9	P906-2002	J-12		
075-020-HP-QC	J-9	P906-2009	J-12		
12RA680105	J-4	P920-100	J-13		
12RA680106	J-4	P920-265	J-20		
12RA680107	J-4	P920-270	J-14		
720B	J-28	P920-315	J-18		
750A	J-30	P920-343	J-16		
753A	J-30	P920-381	J-17		

Totaline® P920-RECOVERY115 Oil-Less Refrigerant Recovery Unit



When dependability and durability is critical, choose the Totaline P920-RECOVERY115 Oil-Less Refrigerant Recovery Unit.

- With our patented 3/4hp Platinum Plus Compressor, the Totaline P920-RECOVERY115 is capable of recovering direct liquid. A larger 1-1/8" piston allows for movement of greater volumes of refrigerant. This feature saves your customer time when servicing a system.
- The larger piston also provides the Totaline Refrigerant Recovery Unit increased durability and longevity in the field.
- The simple operation consists of one-line-in, one-line-out technology. Easily self evacuate the lines to ensure air is not entering the recovery cylinder, then simply switch the valves to recover and go about your work. When recovery is done, evacuate the unit with a switch of the valve to ensure refrigerants are not cross contaminated.
- The Totaline Refrigerant Recovery Unit is designed with the technician in mind. The unit is compact with a low center of gravity. No worrying about this unit sliding around in the truck.
- With our compact design comes a lighter unit with extra ease of mobility. Weighing in at only 34 lbs. the unit can easily be carried up ladders or stairs to any jobsite.
- Totaline incorporates the latest technology in injection mold design with internal channels increasing airflow across the compressor head and motor.
- Field repairable with only one kit.
- Assembled in the U.S.A.

Ordering Information:

Part No.	Description
P920-RECOVERY115	Oil-Less Refrigerant Recovery Unit

Accessories:

KIT006	Low Pressure Cut-Out Kit for 115v and 230v models.
KIT007	Tank Full Kit for 115vt Models.

Replacement Parts:

C-032-F	3cu. Replacement Filter Drier
RGA502	Replacement Low Pressure Gauge
RGA802	Replacement High Pressure Gauge
CPK076	Compressor O-Ring Rebuild Kit
CPK077	Compressor Piston Rebuild Kit
CPK078	Compressor Head Rebuild Kit
RSC019	Shaft Seal - Compr. to Motor
CPK079	Complete Compressor Kit -

Contains all above except replacement gauges and filter drier.

Recovery Rates - Per ARI 740 Standard

P920-RECOVERY115	R22	R410a	R134a	R407c
Push/Pull Liquid	13.60lbs/min.	13.99bs/min.	10.58bs/min.	13.75bs/min.
Direct Liquid	4.08lbs/min.	4.98lbs/min.	3.79lbs/min.	5.02lbs/min.
Direct Vapor	.35lbs/min.	.23lbs/min.	.23lbs/min.	.31lbs/min.

Power requirements:

115 Model: 115VAC, 50/60 Hz,
1-phase, MIN CKT AMP 15, MAX
Dimensions (LxWxH): 16-in x 10-in x 13-in
Weight: 34-lbs/15.4-kg (shipping 38-lbs/17.2-kg)
Safety limit switches: High pressure = 550-psi
Low pressure = 10-in Hg (opt)

Totaline® Dual Stage Vacuum Pumps 1.8 CFM - 7 CFM



The HVAC/R professional's best friend, Totaline Vacuum Pumps are affordable, reliable, built to last and available in three sizes: 1.8 CFM, 4 CFM and 7 CFM.

- High ultimate vacuum: 3 x 10⁻¹Pa (25 microns)
- Quick flow rate
- Portable, smaller and lighter in design
- Stable equipped with thermal protector
- Reliable force feed lubrication system
- Power plug easy connection with various plugs
- One year limited warranty

PART NO	Voltage 110-220 Volt/ 50-60 Hz	Pa	Microns	Stage	Power HP	Intake Fit- ting	Oil Capacity ml	Dimensions Inch	Net Weight lbs
P920-VAC4D015	1.5 CFM@50Hz 1.8 CFM@60Hz	3X10 ⁻¹	25	2	1/4	1/4" Flare	200	12.1"x4.8"x9.0"	18.5
P920-V AC4D035	3.5 CFM@50Hz 4.0 CFM@60Hz	3X10 ⁻¹	25	2	1/3	1/4" & 3/8"Flare	350	13.2"x5.4"x9.8"	24.7
P920-VAC4D060	6 CFM@50Hz 7 CFM@160Hz	3X10 ⁻¹	25	2	3/4	1/4" & 3/8"Flare	700	15.7"x5.7"x10.6"	36.4

3/4hp Platinum Plus Compressor Assembly

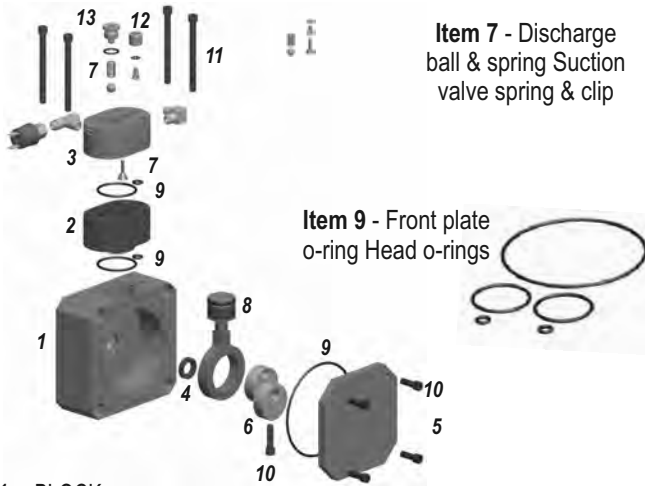

Item 7 - Discharge ball & spring Suction valve spring & clip

Item 9 - Front plate o-ring Head o-rings

- 1 BLOCK
- 2 COMPRESSOR CYLINDER
- 3 COMPRESSOR HEAD
- 4 LIP SEAL
- 5 COVER PLATE
- 6 COMPRESSOR COUNTER WEIGHT
- 7 COMPRESSOR HEAD KIT
- 8 COMPRESSOR PISTON KIT
- 9 COMPRESSOR O-RING KIT
- 10 SCREW SOCKET HEAD CAP ¼ -20 X 1.00 LONG STEEL BLACK
- 11 SCREW SOCKET HEAD CAP ¼ -20 X 3.00 LONG STEEL BLACK
- 12 SUCTION VALVE PLUG
- 13 DISCHARGE PLUG / WITH O-RING

Ordering Information:

Replacement Parts:

- C-032-F. 3cu. Replacement Filter Drier
- RGA502 Replacement Low Pressure Gauge
- RGA802 Replacement High Pressure Gauge
- CPK076 Compressor O-Ring Rebuild Kit
- CPK077 Compressor Piston Rebuild Kit
- CPK078 Compressor Head Rebuild Kit
- RSC019 Shaft Seal - Compr. to Motor
- CPK079 Complete Compressor Kit - Contains all above except replacement gauges and filter drier.

REFRIGERANT RECOVERY

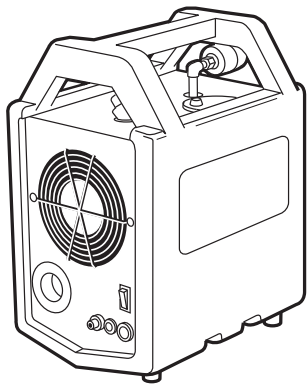

- Enjoy faster more reliable recovery — larger 3/4-hp oil free compressor easily services larger cooling systems.
- Finish sooner — 30% faster recovery rates versus our previous Totalvac design.
- Now has covers

More Durable

- Don't "baby sit" the liquid recovery process — special ball discharge valve prevents slugging and premature compressor failure.
- Enjoy longer service life — switch halts recovery when A/C system is under a 10" vacuum to prevent excess wear to compressor components.
- Worry less — top handle shields valves, ports and gauges for better protection. Rugged double-walled plastic housing absorbs shock and abrasion.

Easier to Operate

- Simplify recovery — two hand valves perform self-evacuation and recovery in fewer steps.
- Start recovery then do other things — automatically halts vapor recovery when process is complete.
- Comfortably tote the compact 30-lb unit to your jobsite by its included shoulder strap. Easy to Field Service
- Prevent downtime — compressor may be overhauled in the field with simple tools and readily available spare parts in about 30 minutes.

SPECIFICATIONS

Vapor Recovery 0.31-lb/min

Recovery Rates (R-22) Liquid Recovery 5.04-lb/min

Push/Pull 14.50-lb/min

Dimensions (L x W x H) 13.5" x 9" x 17"

Weight 30-lb 38-lb Shipping

Compressor 0.75-hp oil free

Power Supply: Unit is equipped with a flanged inlet power receptacle. Overseas models included an adapter

for different power cords. Recommended maximum length on 14 gauge power cord is 20 ft.

Included with Purchase

- Shoulder strap
- Now optional see below
- One 3-cubic inch in-line filter

Accessories

12RA680106.....30 lb. Cylinder (Puron)

12RA680105.....50 lb. Cylinder (Puron)

12RA680107.....50 lb. Cylinder with liquid switch (Puron)

Optional Float Accessory Kit

KIT002 115V for P706.0001-L

KIT003 220V for P706.0002-L

Includes:

6 ft. float cable Full indicator light

Float By-pass switch Hard wiring instructions

PART NO	DESCRIPTION
P706-0001-L	with low pressure switch, 115/60/1
P706-0002-L	with low pressure switch, 220/50/1

REFRIGERANT RECOVERY

EVAC COMMERCIAL™ OPEN DRIVE HIGH PRESSURE RECOVERY SYSTEM

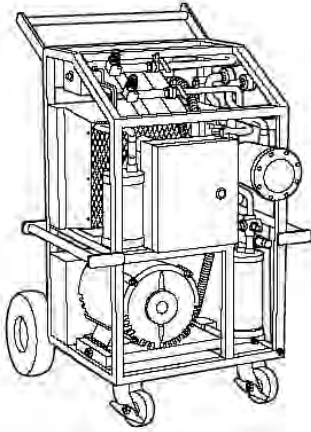

Shaves hours off recovery times on chillers and large A/C or refrigeration systems.

FASTER SPEED

- Recovers 325-lb/min liquid and 6-lb/min vapor (R-22).

HIGH DURABILITY

- Rugged 3-Hp open drive compressor provides years of reliable service, even on refrigerants heavily contaminated with oil, air, moisture, and acids.

SERVICES MOST HP REFRIGERANTS

- R-12, R-22, R-114, R-134a, R-404, R-407, R-500, R-502, R-507, MP39 and other high pressure refrigerants or blends (does not service very high pressure refrigerants such as R-13 and R-23).

EASY OPERATIONS

- Purging lines and switching from liquid to vapor recovery modes simply involves turning three 3-way hand valves and rerouting a hose.

SPECIFICATIONS

Liquid Push/Pull (R-22) 325 lb/min
 Vapor Rate (R-22) 6.0 lb/min
 Final Vacuum 15-in. Hg
 Motor 3 Hp
 Power: Controls 103-127 VAC, 50/60 Hz, 1φ, 15A
 Connections 3/4" flare
 Dimensions (L x W x H)
 Electromechanical
 32 in. x 29 in. x 45 in. (114 cm)
 Weight Electromechanical: 310 lb
 Shipping: 375lb.

Included with Purchase:

DESCRIPTION	PART NO.
3 Ph units have separate 115V Controls Power cord.	---
Two cords total.	
Two each 3/4-5/8" and 5/8-1/2" reducing fittings	---
-Two 48cu.in filter drier cores	FD-048-CR
-One 3/4" x 20 ft hose	075-020-HP-FB
-Two 3/4" x 10 ft hoses	075-010-HP-FB

Optional Accessories:

DESCRIPTION	PART NO.
Spare filter driers—48cu.in filter drier cores	FD-048-CR
Compressor fluid, 1 gal	OIL-POE-1G
100, 250 and 1,000 lb tanks	
with 3/4" ports and dip tubes	---
Custom sized ASME tanks	---

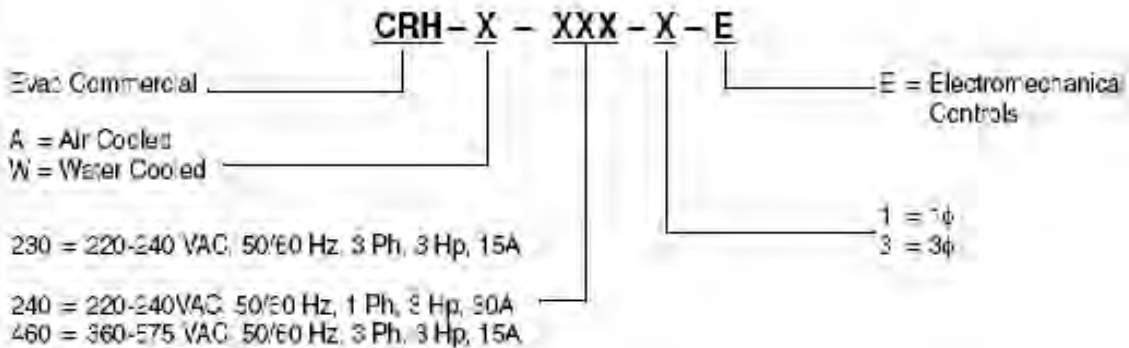

REFRIGERANT RECOVERY

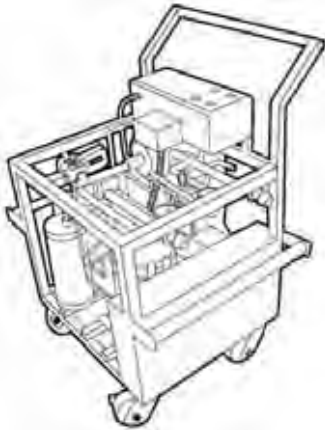

SPECIFICATIONS

Recovery Rates (R-11)

Open Drive Model

Liquid = 100-lb/min

Vapor = 0.66-lb/min

Final Vacuum: 29-in Hg

Power: Recovery Unit

103-127VAC, 1 ϕ , 50/60 Hz, 1.5-hp, 10A

Weight

Open Drive Model: 160-lbs

Shipping: 210-lbs

Connections: 3/4" male flare

fittings with ball valves

Warranty 1-year Parts

Dimensions (L x W x H)

Electromechanical 23" x 27" x 34"

LOVAC outpaces other recover systems, especially when refrigerant is contaminated with moisture, oil, or noncondensibles

FASTER SPEED

- Recovers R-11 at 100-lb/min liquid and 0.66-lb/min vapor.

NONCONDENSIBLES? NOT AN ISSUE!

- LOVAC's compressor works against very high head pressures and the water cooled condenser and subcools recovered refrigerant to minimize the effects of noncondensibles.

HIGH DURABILITY

- Rugged 2.0 Hp open drive compressor stands up to difficult recovery conditions better than vacuum pumps.

REFRIGERANT COMPATIBILITY

- Serves all low pressure refrigerants. Switching between R-11, R-123, and R-113 simply involves evacuating the recovery unit, changing fluid and replacing two external filters.

EASY OPERATION

- Purging lines and switching from liquid to vapor recovery modes simply involves turning three valves and rerouting hoses.

Included with Purchase:

DESCRIPTION	PART NO.
One power cord 50 ft.	---
Two each 3/4-5/8" and 5/8-1/2" reducing fittings	---
-Two 48cu.in3 filter drier cores	FD-048-CR
-One 3/4" x 20 ft hose	075-020-HP-FB
-Two 3/4" x 10 ft hoses	075-010-HP-FB

Optional Accessories:

DESCRIPTION	PART NO.
- 48-cu.in filter drier cores	FD-048-CR
Compressor fluid, 1 gal	OIL-POE-1G
440 and 880 lb recovery tanks with 3/4" ports	---
Tank float safety cables and adapters	---

PART NO. NOMENCLATURE

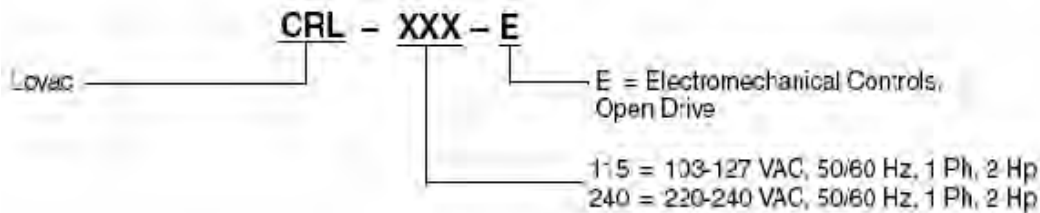

REFRIGERANT RECOVERY

HANDIVAC™ HIGH CAPACITY OIL-LESS RECOVERY SYSTEM

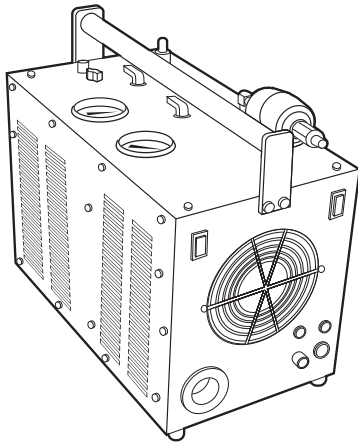

SPECIFICATIONS

Push/Pull (R-22)* 25-lb/min
 Direct Liquid (R-22) 7.8-lb/min
 Vapor (R-22) 0.62-lb/min
 Weight 63-lbs (28.6 kg)
 Motor 1.5 Hp
 Connections 3/8" Flare
 Dimensions (L x W x H) 18" x 10" x 16"
 Float Connection 3-pin BH
 Low-Pressure Switch 15" Hg
 *Push/pull rates using 3/8" lines.

Extra condensing capacity and higher horsepower for faster refrigerant transfer rates and longer component life.

High ARI Certified Recovery Rates (R-22)

SPEED ENHANCING FEATURES

- Dual 0.75 hp oil-less compressors double recovery rates for servicing commercial cooling units.
- Unit self-evacuates prior to performing recovery.
- Compressor pulls directly on liquid with safeties to protect against slugging.

LESS MAINTENANCE

- Oil-free compressor lessens maintenance hassles. Easily switches between R-12, R-22, R-134a, R-500, R-502, R-409, R-410a, MP39 and other high pressure refrigerants and blends.
- Dual fans provide abundant air flow to properly cool the compressor motor & head as well as other internal components for longer service life.

SAFETY FEATURES

- High head pressure shut off at 425-psi.
- Low pressure shut off at 15-in Hg.
- Operational 80% tank full float valve shut off.

Push/Pull* direct liquid vapor

RTO-500 25-lb/min 7.8-lb/min 0.62-lb/min

* Push/pull rates using 3/8" hose.

DESCRIPTION	PART NO.
3/8" male flare x 3/8" female flare	RFD154
6-ft float cable and 3 pin (BH) connector	FVC-006

Optional Accessories:	
DESCRIPTION	PART NO.
Spare filter driers: -In-line filter 3 in3, 1/4" flare	FD-003-25
-3/8" male flare x 3/8" female flare	RFD154
5, 10 and 20 ft x 1/4" hoses	---
30, 50, 250 and 1,000 lb recover tanks	---

PART NO. NOMENCLATURE



RTO = Twin Cylinder Oil-less compressor

500 = Handivac System

RTO - 500 - XXX - F

Float Cable Connection

115 = 115 VAC, 50 Hz, 1Ø, 15A
 240 = 240 VAC, 50 Hz, 1Ø, 15A

REFRIGERANT RECOVERY

MITYVAC™ LIGHTWEIGHT OPEN DRIVE RECOVERY SYSTEM

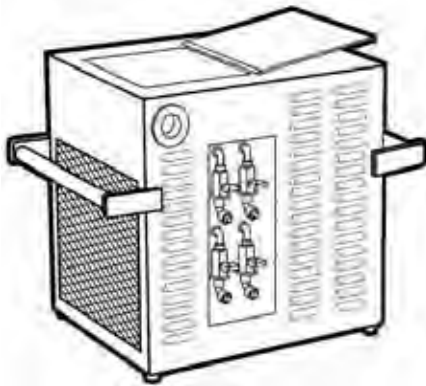

SPECIFICATIONS

Liquid Push/Pull (R-22): 55 lb/min
 Vapor Rate (R-22): 1.56 lb/min
 Final Vacuum: 15 in. Hg
 Weight: 145 lbs. (180 shipping)
 Motor: 2.0 Hp
 Connections: 1/2" Flare
 Dimensions: (L x W x H)
 18" x 14" x 19"
 (46cm x 35cm x 48cm)

Offers the additional speed and durability of an open drive compressor in a lightweight package.

ACCELERATES RECOVERY PROCEDURES TO SAVE LABOR AND REDUCE COOLING SYSTEM DOWNTIME

- 2.0-hp compressor moves refrigerant through a 1/2" port and valving system at sizzling rates of 55- lb/min liquid and 1.56-lb/min vapor (R- 22).
- High capacity air cooled condenser with 700-cfm fan maintains recovery rates at high ambient temperatures.

RUGGED DESIGN OFFERS LONGER SERVICE LIFE AND GREATER FLEXIBILITY

- Open drive compressor is virtually impervious to the acids and contaminants that burnout hermetic or oil-less compressors.
- Services R-12, R-22, R-500, R-502, R-134a, MP39, R-409a, R-507 and other high pressure refrigerants and blends. Can be reprogrammed to service newly introduced refrigerants.

SIMPLE OPERATING PROCEDURES

- Purging lines and switching from liquid to vapor recovery modes simply involves turning three 3-way hand valves — no switching hoses is necessary.

Included with Purchase	
(HOSES NOT INCLUDED):	
DESCRIPTION	PART NO.
50 ft. power cord	---
Two in-line 30cu.in filter driers	FD-030-50
Optional Accessories:	
DESCRIPTION	PART NO.
Recovery hoses - four required:	
1/2" x 10 ft. hoses	050-010-HP-FB
1/2" x 20 ft. hoses	050-020-HP-FB
Spare filter driers	FD-030-50
Recovery tanks (float valves optional)	
-1000-lb capacity	CYL-0250
Tank float safety cables and adapters	CYL-1000

PART NO. NOMENCLATURE

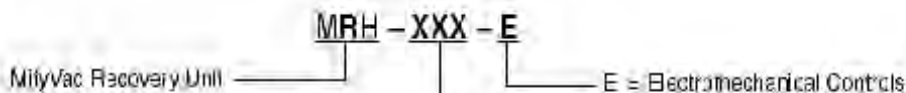

115 = 103-127 VAC, 50/60 Hz, 1 Ph, 2.0 Hp, 20A
 240 = 220-240 VAC, 50/60 Hz, 1 Ph, 2.0 Hp, 15A

Compressors,
Chillers, Condensers

Motors

Electrical

Heating
Components

Indoor Air
Quality

Thermostats

Oils &
Chemicals

Accessories, Supplies
& Commodities

Tools &
Instruments

Refrigeration

Tools & Instruments

Compressors, Chillers, Condensers
 Motors
 Electrical
 Heating Components
 Indoor Air Quality
 Thermostats
 Oils & Chemicals
 Accessories, Supplies & Commodities
 Tools & Instruments
 Refrigeration

RECOVERY ACCESSORIES

RECOVERY CYLINDERS

- Standard recovery tanks have small diameter ports that restrict refrigerant flow and slow your recovery procedures. Carrier 1000-lb and 250-lb tanks have been fitted with full port 3/4" service valves and copper dip tubes that eliminate restrictions and enhance throughput for faster recovery.
- Available in 30 lb, 50 lb, 250 lb, and 1000 lb capacities. Customer ASME vessels exceeding 1000 lbs and with larger ports are also available.

PART NO	DESCRIPTION	PORT SIZE	DRY WEIGHT	DIMS (OD X H)
CYL-1000	1000 lb Tank only	3/4"	358 lbs	30" x58"
CYL-1000-LS	1000 lb w/80% shut off switch	3/4"	359 lbs	30" x58"
CYL-0250	250 lb Tank only	3/4"	86 lbs	15" x49"
CYL-0250-LS	250 lb w/80% shut off switch	3/4"	87 lbs	15" x49"

ASME CYLINDERS

ASME Tank Features

- Mounted on casters
- Pressure gauge
- 80% tank full float switch
- Liquid and vapor ports
- Dual pressure relief valves
- Liquid level indicator
- Bottom drain connection

PART NO. NOMENCLATURE

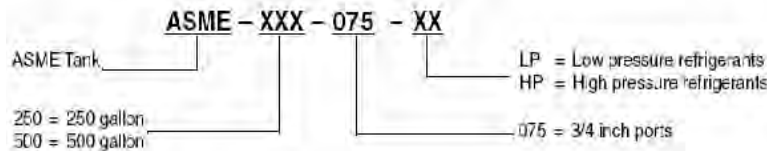

SPECIFICATIONS

	ASME250	ASME500
Water Capacity	250 gal	500 gal
Dry Weight	650 lbs	1,200 lbs
Length (A)	94 in.	113 in.
Diameter (B)	30 in.	37 in.
Height (C)	42 in.	49 in.

Refrigerant Capacity at 80% Full

	ASME250	ASME500
R-12	2,195 lbs	4,390 lbs
R-22	2,000 lbs	4,000 lbs
R-134a	2,105 lbs	4,030 lbs
R-500	2,034 lbs	4,068 lbs
R-11	2,459 lbs	4,929 lbs
R-123	2,440 lbs	4,880 lbs

FLOAT VALVE CABLE

PART NO	DESCRIPTION
FVC-006	6-ft. Cable and connector for 80% shut off switches on Cylinders
FVC-012	12-ft. Cable and connector for 80% shut off switches on Cylinders

RECOVERY HOSES

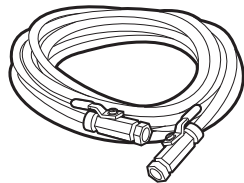

PART NO	DESCRIPTION	HOSE SIZE
025-010-HP-FB	1/4" x 10 ft, flare w/ball valves	1/4 inch
025-020-HP-FB	1/4" x 20 ft, flare w/ball valves	1/4 inch
025-010-HP	1/4" x 10 ft, no isolation	1/4 inch
025-020-HP	1/4" x 20 ft, no isolation	1/4 inch
038-010-HP-FB	3/8" x 10 ft, flare w/ball valves	3/8 inch
038-020-HP-FB	3/8" x 20 ft, flare w/ball valves	3/8 inch
038-010-HP	3/8" x 10 ft, no isolation	3/8 inch
038-020-HP	3/8" x 20 ft, no isolation	3/8 inch
050-010-HP-FB	1/2" x 10 ft, flare w/ball valves	1/2 inch
050-020-HP-FB	1/2" x 20 ft, flare w/ball valves	1/2 inch
050-010-HP	1/2" x 10 ft, no isolation	1/2 inch
050-020-HP	1/2" x 20 ft, no isolation	1/2 inch
075-010-HP-FB	3/4" x 10 ft, hi pressure, flare w/ball	3/4 inch
075-010-HP-QC	3/4" x 10 ft, hi pressure quick connect	3/4 inch
075-020-HP-FB	3/4" x 20 ft, hi pressure, flare w/ball	3/4 inch
075-020-HP-QC	3/4" x 20 ft, hi pressure, quick connect	3/4 inch

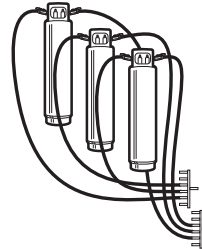

MANIFOLDS

Manifolds allow recovery operator to transfer refrigerant simultaneously to multiple tanks or to pull vapor or liquid from multiple pickup points on the cooling system for faster speed.

PART NO	DESCRIPTION
RM-075-6	3/4" connections, 6 valves
RM-050-6	1/2" connections, 6 valves

RECOVERY ACCESSORIES

ENVIROPURGE™ HIGH PERFORMANCE PURGE SYSTEM

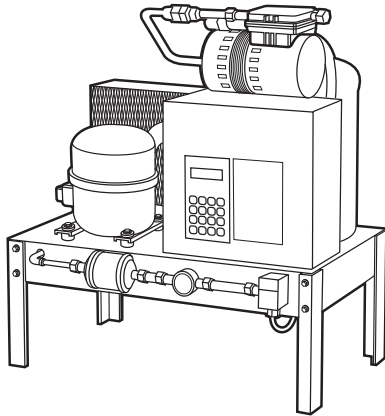

Fast, reliable purging for low-pressure chillers. The Enviro-Purge system removes air and other noncondensibles from low pressure centrifugal chillers while minimizing the loss of refrigerant that normally accompanies the purging process. Purging is fast and microprocessor-controlled to match each chiller's requirements, and to provide historical data for studying purge trends and troubleshooting.

- **Fast, efficient, noncondensibile separation** — Nearly twice the evaporator coil surface area of typical purge units means fast, efficient refrigerant separation.
- **Easy, hassle-free installation** — Ships pre-assembled and connects to existing ports on all types of chillers. Mounts conveniently near floor level.
- **Simple operation** — Application-specific microprocessor controls enhance purge capabilities and provide a user-friendly software interface.
- **High reliability, low maintenance** — Prefilter drier system removes moisture and debris from refrigerant before it enters the purge vessel. Stainless steel construction further protects the purge tank against corrosion.
- **Safeguards Refrigerant** — Four temperature sensors monitor and control purge operations; alarms alert operator to "trouble" conditions so refrigerant loss can be avoided. Display can be in °F or °C.

RAPID NONCONDENSIBLE SEPARATION

The 1/3-hp condensing unit and oversized 350-cu.-in. purge vessel combine to process more refrigerant vapor — faster. A patented reheat/re-expansion circuit provides maximum separation efficiency, and Enviro-Purge discharges only 0.48 lb. of refrigerant per pound of noncondensibles, or just 0.0049 lb when the optional carbon canister is used.

CONSERVES REFRIGERANT

Enviro-Purge's microprocessor control improves purge efficiency and prevents refrigerant loss, using multiple safeguards against "false purging." Four temperature sensors provide continuous monitoring of purge operating conditions in either °F or °C. When excessive purging is detected, the LCD alerts the operator to increasing chiller leaks.

CONVENIENT REMOTE INTERFACE

Built-in RS-232-C interface allows energy management systems or any remote PC to monitor and control purge operations.

PART NO	DESCRIPTION	REFRIG
EMS611-011	110 VAC, 50/60 Hz, 1 , 15A	11
EMS522-011	220 VAC, 50 Hz, 1 , 15A	11
EMS611-113	110 VAC, 50/60 Hz, 1 , 15A	113
EMS522-113	220 VAC, 50 Hz, 1 , 15A	113
EMS611-114	110 VAC, 50/60 Hz, 1 , 15A	114
EMS522-114	220 VAC, 50 Hz, 1 , 15A	114
EMS522-123	220 VAC, 50/60 Hz, 1 , 15A	123
EMS611-123	110 VAC, 50/60 Hz, 1 , 15A	123
CARBCAN	Carbon canister	--

SPECIFICATIONS

Weight	175 lbs./ Shipping 210
Approximate Dimensions	36" x 25" x 30"
Condensing Unit Refrigerant	R-134a
Safety Certification	ETL listed to UL, CSA and CE safety standards.

RECOVERY ACCESSORIES

MINIPURGE™ PORTABLE HIGH AND LOW PRESSURE PURGE UNIT

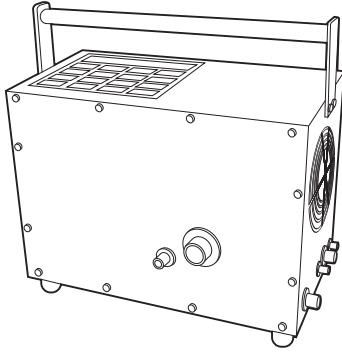

During normal operation the unit continuously displays and scrolls several system temperatures plus the current total pumpout time and cycle count. Eliminate air from high or low pressure cooling systems to improve cooling efficiency and reduce energy costs.

UNIVERSAL COMPATIBILITY

Eliminates air from either high or low pressure refrigerants. Simply evacuate the unit before using on different refrigerant types.

HIGHLY PORTABLE

Smallest and lightest purge unit on the market. At 65-lbs in weight, it is readily hand carried.

FAST PURGE SPEED

Oil-less transfer compressor accelerates the purge process by pulling vapor from the cooling system and forcing processed refrigerant liquid back into the cooling system.

HIGHER EFFICIENCY FOR BETTER REFRIGERANT CONTAINMENT

- Vapor is pumped through a high capacity condenser then compressed in a purge vessel. Microprocessor controls calculate the most efficient time to purge noncondensibles.
- Achieves discharge efficiency as high as 0.2 lb-refg/lb-noncondensibles on some refrigerants. Three to four times more efficient than thermal purge units on the market.

Optional Accessories:

PART NO	DESCRIPTION
FD-003-25	1/4 in. flare in-line filters
025-010-HP-FB	Refrigerant Hoses: 1/4" x 10-ft with ball valves
025-020-HP-FB	Refrigerant Hoses: 1/4" x 20-ft with ball valves

SPECIFICATIONS

Connections	3/8" flares
Dimensions (L x W x H)	18" x 10" x 16" (35 cm x 35 cm x 35 cm)
Weight	65 lb
Operating Environment	32-120°F, 5-95% RH, noncondensing
Storage Environment	(-40)-150°F, 5-95% RH, noncondensing
Warranty	1-year parts

PART NO. NOMENCLATURE

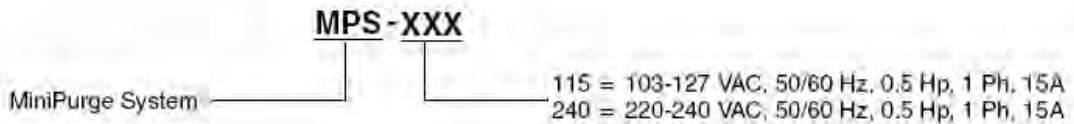

Tools & Instruments

TOOLS

Heavy Duty Tension Tool for installing Duct Straps



- 120 lb to 175 lb duct straps
- Manual tension control
- Neatly cuts off straps
- Metal construction
- Packaged individual box

PART NO	DESCRIPTION
P298-CT300	Manual Cut Off Heavy Duty Tension Tool For 120-175 lb Ties



Ratchet Action Crimp Tool

The P298-RACT crimp tool crimps solderless terminals and connectors for the 22-10 AWG range. It has a pre-set crimp depth that provides the optimum combination of tensile strength and electrical integrity in the finished termination. Since the tool is ratcheted, it will only release the crimp after the jaws are fully compressed thus eliminating variability from crimp to crimp. It is anticipated the technicians who perform a high volume of electrical repairs will want to purchase the P298-RACT crimp tool.

PART NO	COLOR	SIZE	DESCRIPTION
P298-RACT	Blue Handle	10" In Length Ergonomic Design	Ratchet Action Crimp Tool



Heavy Duty Wire Stripper

Heavy duty wire stripper that can strip all types of wire from 24 to 10 AWG. (0.2 to 6.0 m)

PART NO	SIZE	DESCRIPTION
P298-WS	Length: 8.07"	Heavy Duty Wire Stripper

TOTALTEST® ACID/MOISTURE TEST KITS



Chemical crystals react with acid or moisture which may be present in system.

PART NO	DESCRIPTION
TT1-002	All-in-Kit. (One Totaltest instrument, 2 Totaltest blue tubes, 2 Totaltest yellow tubes, Kits case)
TT2-002	Standard pack of 6 replacement test tubes (yellow)

THE TOTALTEST® KIT INCLUDES:

- One TOTALTEST® Instrument
- Two TOTALTEST® Test Tubes
- TOTALTEST® Kit case.
- Standard package of 6 replacement test tubes.

PART NO

TT1-001

REPLACEMENT TEST TUBE PACK INCLUDES:



- 5 Test Tubes
- Std. package of 6 replacement test tubes.

PART NO

TT2-001

REPAIR KIT INCLUDES:

- Plastic holder for instrument
- Washer
- Std. package of 6 replacement test tubes.

PART NO

TT3-001

TOTALINE® POCKET THERMOMETER ANALOG, ROUND HEAD AND DIGITAL THERMOMETERS

- 5" Stainless Steel stem
- Unbreakable lens
- Readout high visibility pointer and numbers
- Can be Recalibrated
- Pocket sheath with safety cup
- +1% division accuracy

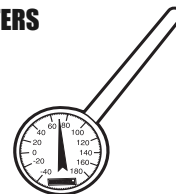

PART NO	DESCRIPTION	TYPE	PACKAGING	STD-PACK
P906-1002	1" Round, -40 to 180° F Temp Range	ANALOG, ROUND	Blister pack	12
P906-2002	1" Round, -40 to 70° C Temp Range	ANALOG, ROUND	Blister pack	12
P906-1004	1" Round, 0 to 220° F Temp Range	ANALOG, ROUND	Blister pack	12
P906-1006	1-3/4" Round, 0 to 220° F & 0 to 100° C Temperature Range	ANALOG, ROUND	Blister pack	12
P906-2009	Swivel, -40 to 100° C Temp Range	DIGITAL	Blister pack	12

Totaline® EZ Digital Multimeter P920-100



P920-100 comes standard with tilt stand protective boot

The Totaline P920-100 EZ Multimeter switches automatically between AC and DC Voltage as well as resistance measurements. No more guessing what range to switch your meter to! The Totaline P920-100 EZ Multimeter does it automatically.

Use the P920-100 to:

- Measure line and control circuit voltages
- Measure resistance of motor windings, transformers, and solenoids
- Make general AC and DC voltage and resistance measurements
- Measure the resistance of elements and electric heater cores
- Test continuity of wiring
- Verify voltage at breakers and outlets
- Use as a back-up meter in your tool box

Features:

- EZ to use one-button operation
- Automatically measures DC volts, AC volts, and Ohms (resistance)
- Large 4,000 count display
- 0 to 600 volts AC and DC
- 10M Ohm impedance
- Auto power off after 10 minutes
- Includes test lead set, batteries, and protective rubber boot
- 3-Year limited warranty

Specifications

Function	Range	Resolution	Accuracy
DCV	1.5V to 4V	0.001V	
	40.00V	0.01V	±(0.5% +4)
	400.0V	0.1V	
	600V	0.1V	±(0.8% +4)
ACV	1.7V to 4V	0.001V	
	40.00V	0.01V	±(0.8% +4)
	400.0V	0.1V	
	600V	1V	±(1.2% +4)
OHM	400.0	0.1	
	4.000k	0.001k	
	40.0k	0.01k	±(0.8% +4)
	400.0k	0.1k	
	4.000M	0.001M	
	40.00M	0.01M	±(2.0% +4)
Safety	CAT II 1,000-V / CATIII 600V		
Power Supply	(2) 1.5 Volt "AA" Batteries		
Battery Life	560 hrs. Alkaline		
Size	33mm x 86mm x 187 (1.3" x 3.4" x 7.4")		
Weight	340g (12oz)		

Standard Accessories

A040	Test lead set
A002	1.5V battery (2)
A101	Protective rubber boot

Optional Accessories

SDK1C	Deluxe test lead set
TLS2000BC	IEC 1010 deluxe test lead kit
A140	Push-on alligator clips
A103	Boot hook
A100	Soft carrying case

Totaline® Clamp-on tester with Digital Multimeter P920-270



10" x 1.3" x 2.5"

Perfect for tight, narrow, spaces.

The new P920-270 with slim jaw and body is ideal for cramped work areas and crowded electrical panels. It can help you:

- Measure flame safety control current
- Test run and start capacitors and motors
- Measure motor run current and capture peak motor start up amperage
- Measure heat anticipator current
- Determine thermocouple voltage
- Test line and control voltages
- Measure heating element resistance
- Measure air temperature in ducts
- Test for the presence of voltage in circuits without contacting the circuit
- Measure temperature differential using relative mode

Features:

- Max display count: 4,000
- Auto & manual ranging
- Analog bar graph (41 segments)
- Data hold
- Low battery indicator
- Over range indication ("OL")
- Peak hold
- Min/Max
- Relative mode
- Hi voltage indicator(>30V AC/DC)
- Non-contact voltage detection
- Auto power off after 30 minutes
- Separate battery compartment
- Low Ohm range (400V)
- Amps AC resolution: 0.01A
- VDC/VAC resolution: 0.1mV
- DCµA measurement (0.01µA resolution)
- Temperature measurement
- Capacitance measurement
- 3-Year limited warranty

Specifications

Basic DC accuracy:	0.5%
DC voltage (maximum):	600V
Resolution (maximum):	0.1mV
AC voltage (maximum):	600V
Resolution (maximum):	0.1mV
DC amps (maximum):	400µA
Resolution (maximum):	0.01µA
AC amps (maximum):	400A
Resolution (maximum):	0.01A
Resistance (maximum):	40MV
Resolution (maximum):	0.1V
Frequency (maximum):	400MHz
Resolution (maximum):	0.001KHz
Capacitance (maximum):	40,000µF
Resolution (maximum):	0.001nF
Diode: test current max	1.5mA
Continuity time; 50ms:	Buzzer sounds at <approx. 35V Response
Agency approval:	CEIEC 1010: CATIII; 600V cULus 3111: pending
Overall dimensions:	10" x 1.3" x 2.5" (255 x 32.5 x 65mm)
Weight:	.8 lbs (363g)

Standard Accessories

GK11M	Standard K-type thermocouple probe
A085	UL listed silicone test lead set with alligator clips (clip-on)
A270	Soft carrying pouch

Optional Accessories

A202	Line splitter
A771	Carbon monoxide adapter
A620	Pressure adapter
TLS2000RB	Deluxe test lead kit

Standard Accessories



A270
Carry Pouch



A085
Test Leads



GK11M
Temperature Probe

P920-270 FAQs

1. How does the non-contact voltage detection work?

This feature allows you to detect the presence of voltage without contacting the circuit with the test leads. By pressing the NCV button and holding the jaw close to the wire or circuit, the meter will inform you both audibly and visually if the circuit is live.

2. What is hi voltage indication? High voltage indication is an audible and visual safety alert informing you that the test leads are in contact with a voltage greater than 30V AC or DC.

3. What is relative mode? Relative mode allows you to perform measurements relative to a stored value. For example, when performing a low resistance measurement, first touching the test prods together and pressing the relative button will subtract the lead resistance from subsequent measurements.

4. Is it possible to determine the maximum current draw on a line that has loads that vary? By activating the min/max mode on the P920-270 it will record the minimum and maximum current measured. This is helpful when trying to see what the maximum load draw is as devices turn on and off.

5. Can I measure motor start up current with the P920-270 clamp-on tester? Yes, the P920-270 has a peak hold function that allows motor start up current to be captured.

6. Can I test the run and start capacitors on motors?

The P920-270 has the ability to measure capacitors up to 40,000 microfarads in size.

7. Do I need an adapter to measure temperature with the P920-270? An adapter is not needed to perform temperature tests with the P920-270. The P920-270 accepts K-type thermo-couple probes with a sub-mini connector.

8. What is the value of having an analog bargraph display?

The analog bargraph allow you to see rapid signal fluctuations occurring too fast to be seen on the digital display. Meters without this feature are unable to show the presence of rapidly fluctuating inputs.

9. Is it possible to measure AC amps on a device that uses a power cord?

Yes, to accomplish this you can use the line splitter (A202). AC amps must be measured by isolating a single wire and the A202 line splitter does this without damaging the power cord.

Totaline® Digital Manometer P920-620



Experience faster, more accurate measurements with a Totaline manometer

Utility and HVAC troubleshooters choose TOTALINE for value and quality. Replace messy U-tubes and expensive pressure gauges with TOTALINE's P920-620 manometer. Isolating difficult pressure problems on natural gas and propane systems has never been easier. Test for leaks in low-pressure gas systems with the confidence of TOTALINE products. Basic accuracy of $\pm 0.5\%$ reading with 0.01 InH2O resolution.

Use the P920-620 to:

- Adjusting appliance regulators
- Setting delivery pressures
- Leakage "shut-in" tests
- Regulator adjustment for pressure and lock-up tests
- Test pressure switch operation on a 2-stage gas furnace in both positive and negative pressures
- Static pressure in air ducts for air balancing
- Check air filters for measuring pressure drop

Features:

- Fast, accurate and affordable
- Auto range
- Easy to read
- Temperature storage
- Auto power off after 40 minutes
- Low battery indication
- 9 Volt alkaline battery included
- Temperature range: 0°C to 50°C
- Optional protective rubber boot
- 3-Year limited warranty

Totaline® P920-620 Digital Manometer specifications

Auto range:	-15 to 48 InH2O
Accuracy	$\pm 0.5\%$ of reading + 5 digits
Resolution	0.01 InH2O
Over pressure maximum	200 InH2O
Auto power off	Yes after 40 minutes
Low battery detection	Yes
Operating temperature	0°C to 40°C
Storage temperature	-10°C to 50°C
Relative humidity	0% ~ 80%
Weight	7oz (200g)
Power	9V alkaline battery

Standard Accessories

A774	Silicone tubing
A603	Brass hose barb fitting (1/4" Hose Barb x 1/8" NPT thread)
Battery	9 volt battery
Manual	

Optional accessories

A612	Optional rubber boot
------	----------------------

Standard accessories



A774
Silicone Tubing

A603
Brass Hose
Barb Fitting

A612
Protective Boot

P920-620 FAQs

- 1. Can I measure negative pressure on my manometer?**
Yes, all models will read from -15" of water to +48" of water.
- 2. How do you compensate for the differences in atmospheric pressure at different altitudes?**
The P920-620 has a push button zero that will zero your base reading at any altitude.
- 3. What does "trim" mode do?** The "trim" mode displays a running average to stabilize the readings when constant changes in pressure won't allow the display to be read.

TIP: Use the A901 Carrying Case to keep your instruments organized. The A901 is constructed of durable canvas fabric, and includes a shoulder strap, moveable partitions, and sturdy zipper closure.

Totaline® Dual K-type Thermometer P920-343



Size: 5.75" x 2.75" x 1.5"
41mm x 152mm x 77mm

Got a 2-channel K-type thermometer that takes simultaneous readings with T1/T2 selection.

The Totaline P920-343 is a reliable, water-resistant tester that accepts K-type thermocouples, the most common type used today. The P920-343 has the ability to be field calibrated, with an easy two step process performed through the keypad, it does not require the use of additional tools. The P920-343 has many uses, including:

- HVAC/R Temperatures: Ambient air, calibrate thermostats, vents, compressor heads, temperature differential and registers
- Food Temperatures: Grill and surface temperatures
- Electrical Temperatures: Cables, circuit breakers, connections, machinery, motors and transformers

P920-343 Features:

- Temperature range -58°F to 2,462°F (-50°C to 1,350°C)
- Easy-to-read main display - displays OFL to show disengaged or open probe
- Thermocouple type indicator
- Display mode indicator (T1, T2, T1-T2)
- On/off button with guard to prevent accidental engagement
- Freezes the reading on the display
- Select input T1 or T2 and display temperature differential (T1-T2)
- Select between Celsius or Fahrenheit display
- Record and display minimum and maximum temperatures
- Comes complete with: 2 GK13M, carrying pouch, rubber boot with tilt stand, battery and manual
- 3-Year limited warranty



Tilt Stand For The P920-343

Specifications

Input	Dual K-type thermocouple
Temperature Range	-58°F to 2,462°F (-50°C to 1,350°C) Auto range
Display	0.1°C/°F : up to 999.9°C/°F 1.0°C/°F : above 1,000°C/F
Accuracy	±3°F(±1.6°C): -58°F to 32°F (-50°C to 0°C) ±0.3% of rdg +1.8°F (1°C) 32°F to 1,100°F (0°C to 600°C) ±0.4% of rdg +1.8°F (1°C) 1,100°F to 2,462°F (600°C to 1,350°C)
Update Rate	2.5 times/second
Key Buttons	On/Off, T1, T2, T1-T2, °C, °F, HOLD
Field Calibration	By key operation
Operating Temperature	32°F to 122°F (0°C to 50°C)
Storage Temperature	-13°F to 158°F (-25°C to 70°C)
Battery	9V
Battery Life	200 hours (alkaline)

P920-343e FAQs

1. **What is the difference between thermocouple and thermistor probes?**
Thermocouple probes utilize the reaction between two dissimilar metals to produce a voltage that changes as temperature changes. A thermistor is a resistive device that produces a change in resistance with a change in temperature. In general, thermocouples offer a wider temperature range and quicker response time than thermistors. Thermistors are typically more accurate than thermocouples.
2. **What are the differences between thermocouple types?**
Each thermocouple uses different metals and therefore have different characteristics. Here are general guidelines:
K-Type - wide temperature range, used in many digital thermometers and multimeters. Identified by a yellow connector.
J-Type - narrower temperature range than K-type, used in analog and digital thermometers. Identified by a black connector.
T-Type - narrower temperature range than J-type but more accurate than K and J types, used in digital thermometers. Identified by a blue connector.
3. **Can different thermocouple types be interchanged?**
No. Since each thermocouple type uses different metals in its construction they have different output characteristics. Using a J-type thermo-couple in a K-type thermometer will cause measurements to be very inaccurate.

Totaline® Non-Contact Thermometer P920-381



Measure hard-to-reach, sensitive, or large moving target temperatures

Use the P920-381 non-contact thermometer to measure surface temperature and watch the LCD immediately display accurate data without the using a probe.

- HVAC/R surface temperatures: Compressor heads, vents, insulation, leaks around cooler or freezer doors, steam traps and registers
- Food Surface Temperatures: Grill & surface temperatures, holding cabinets, serving temperatures and storage temperatures
- Electrical Surface Temperatures: Cables, circuit breakers, connections, machinery, motors and transformers

Features:

- Easy to use single button operation
- 0.1 resolution for best reading
- Last reading hold
- Soft holster pouch included
- 8:1 distance to spot ratio
- Large, easy to read display
- °C and °F selectable
- 9V battery included
- Temperature range: 0°F to 500°F (-18°C to 260°C)
- 3-Year limited warranty

Specifications

Temperature Range:	-18°C ~ 260°C (0°F ~ 500°F)
Accuracy	±2% or ±2°C or ±3°F whichever is greater
Repeatability	±2% of reading, or ±2°C, whichever is greater
Response Time	500 m second
Spectral Response	7µm ~ 14µm
Emmissivity : Fixed	0.95
Distance to Spot Size	8:1
Laser Sighting	381: with laser
°C/°F Select	Yes
Display	4 digits
Display Resolution:	0.1
Display Hold	Last reading display for 7 sec.
Low Battery Detection	Yes
Back Light	Yes
Operating Temperature	0°C ~ 50°C
Storage Temperature	-25°C ~ 70°C without battery
Relative Humidity	10% ~ 95%
Weight	7oz (200g)
Dimension	155mm x 127mm x 35mm
Power	9V alkaline or NiCd battery

P920-381 FAQs

1. What does “distance to spot ratio” mean?

The laser spot needs to be showing inside the target area. An 8:1 “distance to spot ratio” means you are measuring a 1” diameter area at a distance of 8”.

2. How far can I measure?

Distance is unlimited. The size of the target area sets the limit on distance for accurate measurements. Example: If the area you wish to measure is 1 foot in diameter, then you will need to be within 8 feet to record an accurate temperature.

3. What is the smallest target I can read?

Approximately one-half inch in diameter.

Totaline® Digital Pocket Thermometer P920-315



Convenient, accurate & affordable

The P920-315 is ruggedly designed to withstand a 10' drop. It has a tapered tip for use with "Pete's" plug. Great for many uses like these applications:

- HVAC/R Temperatures:
Ambient air, calibrate thermostats, vents, compressor heads and registers
- Food Temperatures:
Grill and surface temperatures, holding cabinets, serving temperatures and storage temperatures
- Electrical Temperatures:
Motor temperatures, motor oil temperatures and transformer temperatures

Features:

- Water resistant
- Easy to read
- Data hold freezes the reading
- Auto power off after 35 minutes
- Low battery indication
- Magnetic case attaches itself to grates and vents
- °C and °F selectable
- LR44 battery included
- Temperature range: -58°F to 300°F (-50°C to 150°C)
- 3-Year limited warranty

Specifications

Temperature Range:	-50°C ~ 150°C (-58°F ~ 300°F)
Accuracy	±1°C or ±2°F
Response Time	500 m Second
°C/°F Select	Yes
Display Resolution:	0.1
Display Hold	Yes
Low Battery Detection	Yes
Operating Temperature	-50°C ~ 150°C (-58°F ~ 300°F)
Power	LR44 button battery

Totaline® AC Safety Volt Check P920-C50

Non-contact detection of 50-1000 VAC, with sound and visual alert.

Determine the presence or absence of AC voltage in insulated wires, wall receptacles, fuses, junction boxes, switches, and any other voltage carrying electrical system. It is not necessary to disconnect the system in question because no contact is required for operation and current flow is not necessary to locate voltage. Simply touch the plastic tip to a connection point or move it along an insulated wire. If AC voltage is present, The P920-C50 will sound an audio alert and an LED light in the probe tip will glow bright red. The illumination will stop at a break in the circuit or wire, and this allows the AC sensor to be used as a troubleshooting instrument. Check for presence or absence of AC voltage in: wires, wall receptacles, fuses, junction boxes, switches, defective grounds, breaker panels, motors, compressors and any other voltage carrying electrical systems.



AC Voltage in junction boxes



AC Voltage in wall receptacles



AC Voltage in switches

Specifications

Operating Range:	50 to 1000 VAC
Accuracy	±1°C or ±2°F
Response Time	500 m Second
°C/°F Select	Yes
Operating Temperature	-20°C ~ 55°C (-4°F ~ 131°F)
Operating Humidity	95% (0 to 30°C)
	75% (30 to 40°C)
	45% (40 to 55°C)
Power	2 1.5Volt alkaline batteries

Benefits:

- Help prevent electrical shocks
 - Non-contact detection of 50 to 1000 VAC
 - Troubleshoot electrical circuits
 - No switch required. Always ready for use
 - Competing products require an ON/OFF switch
 - Sound & visual Alert
- Sound and bright red glow indicates voltage. Buzzer will not react to static electricity, only AC voltage

Totaline® Clamp-on tester with Frequency and Capacitance P920-265



8" x 3"

Perfect for tight, narrow, spaces

The new P920-265 with slim jaw and body is ideal for cramped work areas and crowded electrical panels. It can help you:

- Test start and run capacitors
- Measure motor run current
- Measure heat anticipator current
- Determine thermocouple voltage
- Test line and control voltages
- Measure heating element resistance
- Measure and adjust variable frequency drives

Features:

- Slim jaw and body design for use in crowded electrical panels
- 4,000 count display
- Capacitance range up to 4,000 microfarads to test run and start capacitors
- 0.1 DC millivolt resolution to accurately measure thermocouples and use optional adapters
- 0.01 AC Amp resolution to measure heat anticipator current
- Frequency measurement capability
- AC/DC volts up to 600V and AC Amps up to 400A
- Diode, resistance, and audible continuity ranges
- Auto / manual ranging
- Data hold
- Auto power off
- CAT III 600V rated
- 3-Year limited warranty

Instrument Specifications

Basic DC Accuracy:	0.5%
DC Voltage (maximum):	600V
Resolution (maximum):	0.1mV
AC Voltage (maximum):	600V
Resolution (maximum):	0.1mV
AC Amps (maximum):	400A
Resolution (maximum):	0.01A
Resistance (maximum):	40MV
Resolution (maximum):	0.1V
Frequency (maximum):	400MHz
Resolution (maximum):	0.001KHz
Capacitance (maximum):	4,000µF
Resolution (maximum):	0.001nF
Diode:	Test Current Max 1.5mA
Continuity :	Buzzer sounds at <approx. 35V Response time; 50ms
Agency Approval:	

Overall Dimensions:	8" x 1.5" x 3.0" (203 x 38.1 x 76.2mm)
Weight:	.6 lbs (272g)

Standard Accessories

GK11M	Standard K-Type Thermocouple Probe
A085	UL Listed Silicone Test Lead Set with Alligator Clips (clip-on)
A270	Soft Carrying Pouch

Optional Accessories

A202	Line Splitter
A771	Carbon Monoxide Adapter
A620	Pressure Adapter
TLS2000RB	Deluxe Test Lead Kit
A301	Single Input Temperature Adapter
A312	Dual Input Temperature Adapter
A213	Microamp Adapter

P920-265 FAQs

- 1. Will the P920-265 measure temperature?**
The P920-265 has the capability to be used with the A301 single input or A312 dual input K- type adapters to measure temperature.
- 2. Are any other adapters available for the P920-265?**
Yes, the P920-265 can be used with the A771 to measure carbon monoxide and the A620 to measure pressure.
- 3. Can I use the P920-265 to troubleshoot variable speed motors?** The P920-265 has the capability to measure frequency making set up and troubleshooting variable speed motors easy.
- 4. Is it possible to measure heat anticipator current with the P920-265?** The P920-265 has a 40A range with 0.01A resolution, which is ideal for measuring heat anticipator and small motor current.
- 5. Can I test the run and start capacitors on motors?**
The P920-265 has the ability to measure capacitors up to 4,000 microfarads in size.
- 6. How do I measure AC Amps on a device with a power cord?** To measure AC amps a single wire must be isolated. The A202 line splitter makes this easy without damaging the power cord.

Totaline® Refrigerant Leak Detector P920-750A



The P920-750A automatically detects all existing refrigerants and blends including 404A, PURON® 410A and R-507 (AZ50).

Whether testing for leaks in air conditioning, refrigeration, or automotive AC, the versatile 700 series spans the diverse needs of technicians, refrigeration engineers, and maintenance personnel around the globe. From freezer coils to heat pumps, experience fast, reliable results that save you both time and money.

Features

- Fully adjustable tic rate to eliminate background concentration and pinpoint leaks
- Visual and audible tic rate
- Optional earphone attachment
- One hand operation
- 3-Year limited warranty

Instrument Specifications

Sensitivity in Ounces Per Year	
R22 or R134a	0.3
Scan Mode with Switchable	Yes
High / Low Sensitivity	
Sensor Type	Corrona discharge
Spare Sensor Included	Yes
Operation	Thumb wheel
Gooseneck Handle Length	16"
Adjustable Tic Rate	Yes
Indication of Leak	Audible and flashing LED
Battery Included	Yes, 2 C-cell
Standard Carrying Case	A700 Soft pouch
Optional Accessories	A713 0.5 ounce per year test vial A710 Earphone A712 Sensor for the P920-750

P920-750A FAQs

- 1. Will TPI refrigerant leak detectors pick up the new 410A PURON refrigerants?**
Yes, the P920-750 series refrigeration leak detector pick up current refrigerants and blends, including 404A and 410A (PURON).
- 2. Should I buy a thumb wheel "tic" adjust or push button "tic" adjust?** The thumb wheel gives you a manual adjustment and the push button adjusts to preset levels. Both are easy to use and work equally well. It's simply a matter of personal preference.
- 3. Why would I want a pump on my refrigeration leak detector?** Generally, refrigeration leak detectors with pumps respond and clear faster as you enter or leave the leak area. This is most important when locating small leaks
- 4. I have a hard time finding a leak when on a rooftop in windy conditions. Will I be able to find a leak in the conditions with your refrigerant leak detector?** Always remember that the refrigerant will travel with the wind. Position yourself down wind and work your way "up stream" in order to trace down a leak. The harder the wind is blowing, the more the concentration of refrigerant will be diluted in the air. It is difficult to find these leaks, but it can be done.
- 5. Is there a way to determine how many parts per million (ppm) a leak of 0.1 ounce per year (oz/yr) is?** A leak of 134a refrigerant measuring 0.1 oz/yr is equivalent to approximately 380 to 400ppm. A leak measuring 0.2oz/yr is equivalent to approximately 760 to 800ppm.

Totaline® Combustible Gas Detector P920-720B



Easily operate the P920-720B with one hand while detecting the presence of combustible gases including natural gas, methane, propane (LPG), gasoline, diesel, and kerosene. Pinpoint leak sources with its audible and visual indicators. An adjustable "tic" rate helps eliminate background gas concentration in contaminated environments.

Use the P920-720B to:

- Trace natural gas lines and fittings for leaks.
- Check gas applications for leaks.
- Check propane tanks, fitting lines, and heaters for leaks.
- Check gas generators for fuel leaks.
- Test confined spaces for gas build-up.

Features

- Instant response
- 10 ppm sensitivity
- Adjustable tic rate
- One-hand operation
- Visual and audible leak indication
- 16" gooseneck
- Soft carrying pouch
- 3-Year limited warranty

Instrument Specifications

Sensitivity:	10 ppm
Operating Temp:	32° to 104°F (0° to 40° C)
Warm-up:	7-10 seconds
Response Time:	Instantaneous
Battery:	3 "C" batteries
Battery Life:	20 continuous hours
Weight:	1.1 lbs.

Totaline® Digital Vacuum Gauge P920-605



Use the P920-605 to Verify the vacuum before you change a refrigerant system.

- Prevents moisture and air being left in the system.
- Finds small leaks.

Features:

- Measure vacuum from 25 to 0 microns
- Reads vacuum in seven international units of measure (Microns, PSI, InHg, mBar, Pascals, Torr, and mTorr)
- Display updates every 0.5 seconds
- Auto power off after 10 minutes when vacuum above 12,000 microns (12 Torr)
- Built in hook for hanging
- Cleanable sensor
- 300 PSI overpressure
- 3-Year limited warranty

Sensor Type	Thermistor
Connection Type	Standard 1/4" NPT male
Vacuum Range	0 - 12,000 microns (0 1600 Pascals)
Accuracy	10% of reading ±10 dgts
Units of Measure	Microns, PSI, InHg, mBar, Pascals, Torr, mTorr
Power Supply	9 volt alkaline battery
Operating Temp:	0° - 40°C (32° to 104°F)

Totaline® Vane and Hotwire Velocity Meter P920-575



Use the P920-575 for:

- Air flow measurements in heating, ventilation and air conditioning systems
- Air duct analysis
- Fume hoods
- Flue Registers
- Exhaust grills
- Hotwire velocity meter enables user to read below 80fpm applications (low flow)

Features:

- (Vane) Air flow 0.4 to 25 m/s (Also reads km/s, ft/min, knots/h, miles/h)
- (Hotwire) Air flow 0.2 to 20 m/s (Also reads km/s, ft/min, knots/h, miles/h)
- Temperature -5° to 175° F (-20° to 80°C)
- Data record function for maximum and minimum temperature and air velocity rearing
- Download to a computer using the RS-232 port and optional A500 cable.
- 39" cable length with Lemo connector
- Data Hold
- Auto Power Off
- Protective boot and soft carrying case included
- 3-Year limited warranty

Specifications

Display	Dual digits LCD with function annunciation
Measurement	m/s, km/s, ft/min, knots, mile/h, °C, °F
Measurement Range and Accuracy:	
Air Flow (Vane)	0.4 ~ 25 m/s (±2% of reading ±3 digits)
(Hotwire)	0.2 ~ 20 m/s (±5% of reading ±3 digits)
Temperature	-5°F ~ 175°F (±1% of reading ±1.0°F ±3 digit)
	-20°C ~ 80°C (±1% of reading ±0.5°C ±3 digit)
Operating Temperature	0 ~ 50°C (32°F ~ 122°F)
Operating Humidity	Less than 80% R/H
Powering	1.5V AAA x 6EA
Optional Accessories	A500 RS-232 cable
	A901 soft shoulder strap carrying case

TOTALINE® TOOL ACCESSORIES



Gas Valve Pressure Adapter P920-A611

Use for checking gas pressure on gas valve where the inlet gas is in a tight or hard to reach location. Can be used with any Totaline digital manometer.



Optional K-Type Probes

Temperature Probe P920-CK20M

Pipe clamp probe for smaller diameter pipes-58° to 212°F (-50° to 100°C)



Temperature Probe P920-CK21M

K-type thermocouple pipe clamp for pipe diameters up to 1.2" and temp. up to 212°F. -58° to 212°F (-50° to 100°C)



Temperature Probe P920-GK13M

Teflon coated temperature probe. Measure temperatures up to 500°F. Use to measure temperature rise. -40° to 500°F (-40° to 260°C)



Silicone Tubing P920-A774

6 Foot length of Silicone tubing for Pressure measurements. Very flexible and will not go hard in in cold temperatures.



Universal T Fitting P920-A605

Ideal for use on setting pressure switches.



Test Leads P920-A080

UL Listed



Test Lead Kit P920-TLS10

Includes:

- A052 Adapters
- A057 Back Probes
- A067 Grabbers

Tools & Instruments

Compressors, Chillers, Condensers
 Motors
 Electrical
 Heating Components
 Indoor Air Quality
 Thermostats
 Oils & Chemicals
 Accessories, Supplies & Commodities
 Tools & Instruments
 Refrigeration

DIGITAL MULTI-METERS

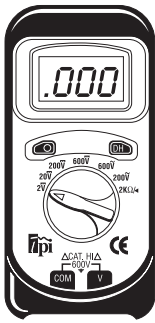

- Compact size fits in pocket
- 2 volt range, allows use of CO attachment and temperature attachment.
- 2k ohm range reads most contactor and relay coils.
- Standard accessories; test leads, batteries, protective boot, instruction manual, and a 3 year limited warranty.

Part No.: 120



- Full function manual range DMM.
- Test continuity in circuits and wires.
- Measure current draw of electrical circuits.
- Measure start and run capacitors of motors and compressors.
- Test diodes for shorts and opens.
- Measure resistance of components.
- Standard accessories; test leads, batteries, protective boot, instruction manual, and a 3 year limited warranty.

Part No.: 135



- Full function manual range DMM.
- Large LCD
- Measures amps to 10 amps both AC & DC.
- Measures DC micro amps for flame rectification circuits.
- Continuity buzzer and diode check.
- Standard accessories; test leads, batteries, protective boot, instruction manual, and a 3 year limited warranty.

Part No.: 133



- Full function manual range DMM.
- Large LCD
- Measures amps to 10 amps both AC & DC.
- Measures DC micro amps for flame rectification circuits.
- Continuity buzzer and diode check.
- Standard accessories; test leads, batteries, protective boot, instruction manual, and a 3 year limited warranty.

Part No.: 153



- Full function auto ranging DMM.
- Test continuity in circuits and wires.
- Measure current draw of electrical circuits.
- Test diodes for shorts and opens.
- Measure resistance of components.
- Standard accessories; test leads, batteries, protective boot, instruction manual, and a 3 year limited warranty.

Part No.: 163

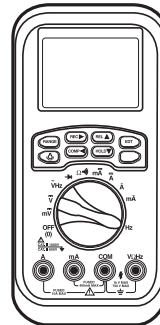

- Auto ranging true RMS DMM.
- Measures Capacitance.
- Test continuity in circuits and wires.
- Measure current draw of electrical circuits.
- Test diodes for shorts and opens.
- Measure resistance of components.
- Standard accessories; test leads, batteries, protective boot instruction manual, and a 3 year limited warranty.

Part No.: 183

FEATURES	120	133	135	153	163	183
Display Count	2000	2000	4000	4000	3260	4000
AC Volts	600	750	750	750	750	750
DC Volts	600	1000	1000	1000	1000	1000
Basis DC Accuracy	0.50%	0.50%	0.50%	0.30%	0.50%	0.30%
AC Amps	NA	10	10	10	10	10
DC Amps	NA	10	10	10	10	10
True RMS	NA	NA	NA	NA	NA	NA
Resistance	2K ohms	20M ohms	40M ohms	40M ohms	32.6M ohms	40M ohms
Capacitance	NA	NA	20,000uF	NA	NA	10,000uF
Frequency	NA	NA	NA	NA	NA	200KHz
Analog Bar Graph	NA	NA	NA	NA	YES	YES
Auto Range	NA	NA	NA	YES	YES	YES
Data Hold	YES	YES	YES	YES	YES	YES
Min./Max	NA	NA	NA	YES	NA	YES
Sleep Mode	NA	NA	NA	NA	NA	YES
Auto Power Off	NA	NA	NA	YES	YES	NA
RS232 (cable & Software)	NA	NA	NA	NA	NA	OPTIONAL
CE or UL Listed	CE cULus 3111-1	CE cULus 3111-1	CE	CE cULus 3111-1	CE cULus 3111-1	CE cULus 3111-1

DIGITAL CLAMP-ON METERS



- Autoranging
- Compact Size
- Test continuity in circuits and wires
- Measure current draw of electrical circuits.
- Measure resistance of components.
- Measure inrush current of motors, relays and solenoids.

Part No.: 255



- Autoranging true RMS clamp-on
- Peak hold, trim mode and data hold functions.
- Measure AC/DC volts, frequency, AC amps and ohms to 40M ohms.
- Analog bar graph and continuity buzzer.
- Standard accessories include soft pouch test leads and a limited 3 year warranty.

Part No.: 293



- Manual range meter measures up to 700 AC amps.
- Peak hold and data hold functions.
- Continuity buzzer.
- Measures AC/DC volts and ohms to 4K ohms.
- Complete with soft pouch, test leads, instruction manual and a 3 year limited warranty.

Part No.: 291



- True RMS and Harmonics features.
- Measures line and controls circuit voltage.
- Measures current draw of electrical circuits.
- Measures inrush current of motors, relays and solenoids.
- Measures resistance of components.
- Standard accessories include soft pouch, test leads and a 3 year limited warranty.

Part No.: 296

FEATURES	255	291	293	296
Display Count	4000	4000	4000	4000
AC Volts	600	600	600	600
DC Volts	600	400	600	600
Basis DC Accuracy	0.30%	0.75%	0.75%	0.75%
AC Amps	400	700	700	700
DC Amps	NA	NA	NA	700
HDR Mode	NA	NA	NA	YES
True Amps	NA	NA	NA	YES
Resistance	40M ohms	4K ohms	40K ohms	40K ohms
Frequency	NA	NA	10K Hz	10K Hz
Temperature		NA	YES	YES
Capacitance		NA	YES	YES
Analog Bar Graph	NA	YES	YES	YES
Auto Range	YES	PEAK ONLY	PEAK ONLY	YES
Data Hold	YES	NA	YES	YES
Min./Max	YES	NA	YES	YES
Trim	NA	NA	NA	NA
Sleep Mode	NA	CE	CE cULus 3111-1	CE cULus 3111-1
Auto Power Off	YES			
CE or UL Listed	CE cULus 3111-1			

Compressors,
Chillers, Condensers

Motors

Electrical

Heating
Components

Indoor Air
Quality

Thermostats

Oils &
Chemicals

Accessories, Supplies
& Commodities

Tools &
Instruments

Refrigeration

Compressors, Chillers, Condensers
 Motors
 Electrical
 Heating Components
 Indoor Air Quality
 Thermostats
 Oils & Chemicals
 Accessories, Supplies & Commodities
 Tools & Instruments
 Refrigeration

DIGITAL CLAMP-ON METERS



- Hand held oscilloscope with True RMS DMM capabilities
- View industrial signals such as motor control, UPS, switching power supplies and PLC controls with 1 MHz bandwidth.
- Capture noise spikes, glitches and evasive intermittents with 25 Mega samples per second sampling rate.
- Continuous autoset.
- Real time display with backlight.
- Waveform storage
- Clitch capture
- Trend mode
- Frequency counter
- Basic DC accuracy to 0.3%
- RS-232C Port
- Designed to meet IED 1010-1 600V Cat III rating.

Band Width	1MHZ
Sample Rate	20 Mega samples per second (single shot)
Channels	Single
Glitch Capture	Yes
Trend Mode	Yes
Auto Set	Continuous
Waveform Memory	8 Locations
Set-Up Memory	8 Locations
Viewing Area	160 x 240 pixels
Contrast	Adjustable
DMM	
True RMS	Yes
Basic DC Accuracy	0.3%
DCV/ACV	Up to 1,000 volts
DCA/ACA	Up to 10 amps
Ohms	Up to 40 Mega ohms
Capacitance	Up to 400 microfarads
Frequency	Up to 2 MHZ

PART NO	DESCRIPTION
440	440 scope plus, 4,000 count true RMS DMM with wave form capabilities, insulated test leads with alligator clips, power supply

DIGITAL POCKET THERMOMETERS

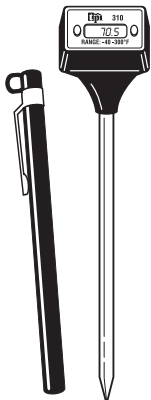

- Flip the LCD to give best angle for viewing
- Easy to read, large LCD
- Data Hold for hard to reach areas
- Auto Power Off saves battery life
- Fahrenheit or Celsius

PART NO
310



- Easy to read, large LCD - 33% larger than the competition
- Use in damp or wet environments - WATER RESISTANT
- Quick response and easy insertion into "Petes" plugs with 3.1 mm dia. stem
- Data Hold for hard to reach areas.
- Auto Power Off saves battery life
- Fahrenheit or Celsius

PART NO
312

NON CONTACT THERMOMETERS

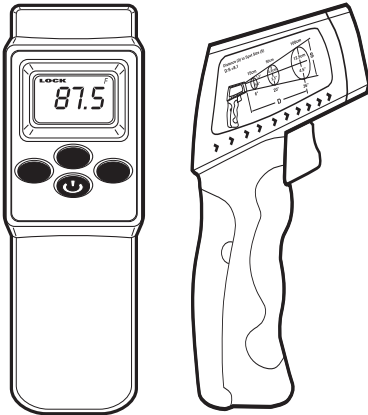

- Easy-to-read, large LCD
- Maintain reading display in hard to read areas with Display Hold (°F or °C Selectable)
- 0.95 Emissivity Provides best accuracy for most surfaces
- 8:1 Distance to Spot Ratio
- 0.1 Resolution provides increased accuracy of reading
- 3 Year limited Warranty

FUNCTION	370 w/o laser	371	373	375	376	377	380/381
Temp Ranges	14° to 500°F 10° to 260°C		14° to 950°F - 10° to 510°C	0° to 950°F 18° to 510°C	-58° to 950°F -50° to 510°C	0° to 1832°F 18° to 100°C	0° to 500°F - 18° to 260°C
Laser Sighting	No	Yes	Yes	Yes	Yes	Yes	No/Yes
Accuracy @ 23°C and .95 Emissivity	-2% of Reading or ±3.5°F whichever is greater above 30°F			30° to 950°F -1°F to 510°C: ±2% of reading or ±3.5°F (2°C) whichever is greater		30° to 950°F- 18° to 1000°C ±2% of reading or ±3.5°F (2°C) whichever is greater	±2% or ±2° C or ±3°F whichever is greater
Response Time	500 milliseconds						
Spectral Resp.	7-14 um						
Operating Temp	32° to 120°F and 0° to 150°C						
Battery Type	9 Volt Alkaline						
Emissivity	0.95			0.3 to 0.99 adjustable			0.95
Display Resolution				0.1°F and 0.1°C or 1°F and 1°C			0.1
Ambient Operating Range				32° to 120°F and 0° to 50°C			
K-Type Range				-40° to 2192°F and -40° to 1200°C			
K-Type Accuracy				±0.5% pf reading +3°F			

COMBUSTIBLE GAS LEAK DETECTORS

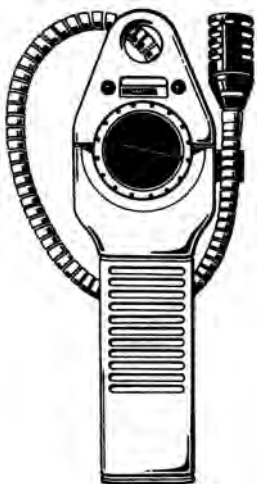

Used to detect gas leaks in the following areas:

- Furnaces
- Water Heaters
- Pinpoint combustible gas leaks in storage tanks
- Gas appliances

FEATURES	720B
Sensitivity	10 ppm
Sensor Type	Low power semiconductor
Warm-up	30 Seconds
Response Time	Instantaneous
Duty Cycle	Continuous
Probe Length	16 inches
Power Supply	3 "C" Cell Batteries

DIGITAL MANOMETERS



APPLICATIONS

- Adjusting appliance regulators
- Setting delivery pressures
- Leakage “shut-in” tests
- Regulator adjustments for pressure and lock-up tests
- Test pressure switch operation on a 2-stage gas furnace in both positive and negative pressures

PART NO.	610	615	620	625
Auto Range	-40.0 mbar to 120.0 mbar			
Accuracy	±(0.5% of reading + 5 digits)			
Over Pressure	500 mbar			
Power Supply	9V			
Relative Humidity	0% to 80% (0°C to +40°C)			
Operating Temp.	32°F to 104°F (0°C to +40°C)			
Storage Temp.	14°F to 122°F (-10°C to +50°C)			
Auto Power Off	After 40 minutes			
Input Type	Single	Single	Differential	Differential
Trim Mode	Yes	Yes	Yes	Yes
Zero Adjust	Yes	Yes	Yes	Yes
Record Min/Max	No	Yes	No	Yes
Units	1	7	1	7
Data Hold	No	Yes	No	Yes



Single Gas CO Analyzer with protective boot, soft shoulder strap carrying case, pump-protecting filter assembly, in-line filter assembly, flue probe. 3 “AA” batteries.

Specification	707
CO Measurement	0-10,000 ppm
O2 Measurement	NA
NO Measurement	NA
NOx (Calculated)	NA
CO2 Measurement	NA
CO/CO2 Ratio	NA
Combustible Leak Indication	NO
Pressure	NO
Pressure Differential	NO
Stack Temp (CH1)	NO
Ambient Temp (CH2)	NO
Temperature Differential	NO
Excess-Air	NO
Air-Free (CO)	NO
Efficiency	NO
Store Memory	10
Data Logging Memory	NO
IRDA (Optional)	NO
Battery	3 “AA” Batteries

Tools & Instruments

A740 INFRARED PRINTER

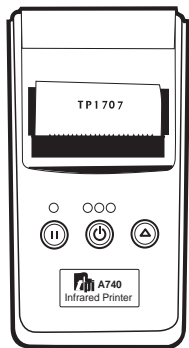

- Easy to use
- Battery operated
- Self test facility
- Adjustable contrast
- Manual paper feed
- Maximum transmitting distance – 16" (45 cm)
- Compatible with most other combustion analyzers.

PART NO	DESCRIPTION
A740	IR Portable Printer

REFRIGERANT GAS LEAK DETECTORS

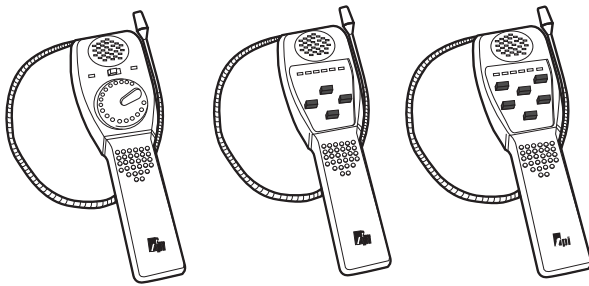

FEATURES/FUNCTIONS	PART NO.		
	750A	753A	755
Sensitivity in Ounces Per Year R-22 or R-134a	0.3	0.2	0.1
Pump	NA	Yes	Yes
Scan Mode with Switchable High/Low Sensitivity	Yes	Yes	Yes
Sensor Type	Corona Discharge	AIT Microtip	AIT Microtip
Spare Sensor Included	Yes	Yes	Yes
Built-In Alarm	No	No	Yes
Operation	Thumb Wheel	Push Button	Push Button
Gooseneck Handle Length (in.)	16	16	16
Adjustable Tic Rate	Yes	Yes	Yes
Indication of Leak	Audible and Flashing LED	Audible and Flashing LEDs	Audible and Flashing LEDs
Battery Included	Yes, 2 C-Cell	Yes, 2 C-Cell	Yes, 2 C-Cell
Standard Carrying Case	A700 Soft Pouch	A700 Soft Pouch	A755 Soft Shoulder Strap Carrying Case

PART NO	DESCRIPTION
750A	Refrigeration Leak Detector and Soft Pouch
753	Refrigeration Leak Detector with Soft Pouch
755	Refrigeration Leak Detector and Soft Shoulder Strap Carrying Case
A712	750A Replacement Sensor Tip
A721	753 & 755 Replacement Sensor Tip
A710	Optional Earphone
A700	Soft Pouch
A755	Soft Shoulder Strap Carrying Case

Compressors,
Chillers, Condensers

Motors

Electrical

Heating
Components

Indoor Air
Quality

Thermostats

Oils &
Chemicals

Accessories, Supplies
& Commodities

Tools &
Instruments

Refrigeration