



MODEL PV

INLINE CENTRIFUGAL DUCT FAN



MODEL FEATURES

- Exhaust air up to 942 CFM with static pressure capabilities to 1.5" w.g.
- Galvanized steel casing with black baked enamel coating
- Pre-wired junction box
- Ideal for applications where space is limited
- Non-overloading backward inclined wheel for efficiency at higher static pressures
- AMCA Seal for Air Performance
- cULus Listed

MODEL OVERVIEW

The POWERVENT (PV) series of direct drive centrifugal in-line duct ventilation fans consists of twelve model sizes 4", 5", 6", 8", 10" and 12.4" respectively. All models are designed for direct connection in-line with standard diameter round ducting. Airflow performance values range from 108 CFM (PV-100) up to 942 CFM (PV-315x).

All PV fan models incorporate a powerful external rotor motor that has been factory matched to a non-overloading backward curved centrifugal fan wheel.

This powerful combination enables the PV fans to deliver exceptional airflow performances against high static pressure typically found in ducted ventilation systems. All motors within PV fans are fully speed controllable using voltage or frequency control regulators.

The PV series of duct exhaust or supply fans have been specifically designed for simple installation and many years of maintenance free operation. The PV fans can be mounted at any angle and at any point along the duct. The totally enclosed motor design allows the PV fans to operate in high moisture, lint and dust laden air. All models are manufactured with high quality materials and workmanship that is supported by a comprehensive **five (5) year warranty**.

All PV Fans feature a corrosion resistant galvanized steel casing with black baked enamel coating and are supplied with a strong mounting bracket and prewired junction box.

The PV100x fans feature Class F motor insulation.



Model PV is available in our Quickship program. All sizes are available for next day shipping from stock.

5 year fan housing and motor warranty

CONSTRUCTION/SPECIFICATION CHECKLIST

Casing

- Manufactured from high grade pressed galvanized steel, with black baked enamel coating.
- Extra long inlet and discharge collars make installation quick and trouble free.
- Supplied with a strong galvanized steel mounting bracket.
- Supplied with a prewired junction box.

Wheel / Impeller

- Backward curved centrifugal type.
- Factory matched to an external rotor motor and dynamically balanced to eliminate vibration.

Motor

- Totally enclosed permanent split capacitor start and run external rotor motors.
- 115V 60Hz (single phase) electrical connection.
- Permanently sealed, self lubricating precision ball bearings.
- Safety Thermal Overload Protection Cut-Out (Automatic Reset Type).
- All Models are suitable for working airstreams up to 140° F

Code Approval

- All models have been independently safety tested by Underwriters Laboratories, Inc. and are UL and cUL Listed.
- Independently safety tested by Intertek Laboratories, and are ETL Listed.
- Independently tested for Airflow Performance. The PV range is licensed to bear the AMCA seal for Air Performance.

ACCESSORIES



BOC
Interior
Air Valve



CAR
Backdraft
Damper



ACOP-VENT
Antivibrating
coupling



SIL
Sound
Attenuator



PER
Plastic louver
shutter



SC 15
Variable speed
control

Please refer to the S&P Group A (Residential/Light Commercial) catalog for a complete line of accessories.

PERFORMANCE/DIMENSIONS

Dimensions in inches/mm

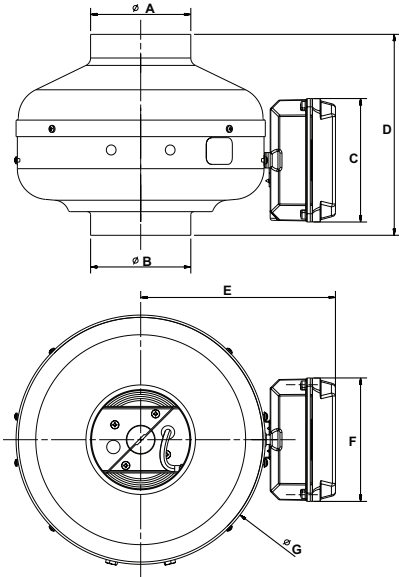

Model	A	B	C	D	E	F	G	Weight lbs(kgs)
PV-100	3 ¹³ / ₁₆ 97.5	3 ¹³ / ₁₆ 97.5	4 ³ / ₄ 120	7 ¹¹ / ₁₆ 196	7 ¹ / ₂ 190	4 ³ / ₄ 120	9 ⁹ / ₁₆ 243	7 3.0
PV-100x	3 ¹³ / ₁₆ 97.5	3 ¹³ / ₁₆ 97.5	4 ³ / ₄ 120	7 ¹¹ / ₁₆ 196	7 ¹ / ₂ 190	4 ³ / ₄ 120	9 ⁹ / ₁₆ 243	7 3.0
PV-125	4 ¹³ / ₁₆ 122.5	4 ¹³ / ₁₆ 122.5	4 ³ / ₄ 120	7 ¹³ / ₁₆ 198	7 ¹ / ₂ 190	4 ³ / ₄ 120	9 ⁹ / ₁₆ 243	7 3.0
PV-125x	4 ¹³ / ₁₆ 122.5	4 ¹³ / ₁₆ 122.5	4 ³ / ₄ 120	7 ¹³ / ₁₆ 198	7 ¹ / ₂ 190	4 ³ / ₄ 120	9 ⁹ / ₁₆ 243	7 3.0
PV-150	5 ¹³ / ₁₆ 147	5 ¹³ / ₁₆ 147	4 ³ / ₄ 120	8 ⁷ / ₁₆ 214	9 ⁵ / ₁₆ 236	4 ³ / ₄ 120	13 ¹ / ₈ 334	11 5.0
PV-150x	5 ¹³ / ₁₆ 147	5 ¹³ / ₁₆ 147	4 ³ / ₄ 120	8 ⁷ / ₁₆ 214	9 ⁵ / ₁₆ 236	4 ³ / ₄ 120	13 ¹ / ₈ 334	11 5.0
PV-200	7 ¹³ / ₁₆ 198	7 ¹³ / ₁₆ 198	4 ³ / ₄ 120	8 ³ / ₄ 223	9 ⁵ / ₁₆ 236	4 ³ / ₄ 120	13 ¹ / ₈ 334	11 5.0
PV-200x	7 ¹³ / ₁₆ 198	7 ¹³ / ₁₆ 198	4 ³ / ₄ 120	8 ³ / ₄ 223	9 ⁵ / ₁₆ 236	4 ³ / ₄ 120	13 ¹ / ₈ 334	11 5.0
PV-250	9 ³ / ₄ 248	9 ³ / ₄ 248	4 ³ / ₄ 120	8 ¹ / ₁₆ 205	9 ⁵ / ₁₆ 236	4 ³ / ₄ 120	13 ¹ / ₈ 334	13 6.0
PV-250x	9 ³ / ₄ 248	9 ³ / ₄ 248	4 ³ / ₄ 120	8 ¹ / ₁₆ 205	9 ⁵ / ₁₆ 236	4 ³ / ₄ 120	13 ¹ / ₈ 334	13 6.0
PV-315	12 ⁵ / ₁₆ 312	12 ⁵ / ₁₆ 312	4 ³ / ₄ 120	9 ³ / ₁₆ 233	10 ⁹ / ₁₆ 269	4 ³ / ₄ 120	15 ¹³ / ₁₆ 401	21 10.0
PV-315x	12 ⁵ / ₁₆ 312	12 ⁵ / ₁₆ 312	4 ³ / ₄ 120	9 ³ / ₁₆ 233	10 ⁹ / ₁₆ 269	4 ³ / ₄ 120	15 ¹³ / ₁₆ 401	21 10.0

Air Performance

Model No.	Nom. RPM	Volts	Max. Watts	CFM v Static Pressure (SP) Ins. WG									Max. SP	Duct Dia. Ins.
				0"	0.125"	0.25"	0.375"	0.5"	0.75"	1.0"	1.25"	1.5"		
PV-100	1400	115	57	108	100	92	85	78	66	52	33	18	1.70	4"
PV-100x	2880	115	84	153	142	130	120	111	96	80	63	34	1.85	4"
PV-125	2350	115	58	128	104	85	74	63	47	32	15	-	1.43	5"
PV-125x	2745	115	85	206	190	170	153	135	110	88	62	33	1.77	5"
PV-150	2750	115	78	245	205	177	157	129	93	59	-	-	1.20	6"
PV-150x	2700	115	130	390	367	340	312	285	233	193	153	110	2.05	6"
PV-200	3100	115	130	402	375	350	327	296	239	179	135	85	1.94	8"
PV-200x	2930	115	180	544	515	485	446	415	360	312	273	230	2.64	8"
PV-250	3000	115	170	568	533	502	471	440	370	312	263	221	2.61	10"
PV-250x	3045	115	214	618	595	570	540	510	450	390	340	297	2.80	10"
PV-315	2600	115	170	654	605	570	525	487	408	333	265	203	2.21	12.4"
PV-315x	2650	115	370	942	905	859	811	762	622	508	440	390	3.90	12.4"

Performance certified is for installation type D-Ducted inlet, Ducted outlet. Performance ratings do not include the effects of appurtenances (accessories). Speed (RPM or RPS) shown is nominal. Performance is based on actual speed of test.



S&P USA Ventilation Systems, LLC., Div. of Soler & Palau Ventilation Group, certifies that the PV range shown herein is licensed to bear the AMCA Seal. The ratings shown are based on tests and procedures performed in accordance with AMCA Publication 211 and comply with the requirements of the AMCA Certified Ratings Program.



The PV-POWERVENT Series fans are California Title 24 compliant and meet ASHRAE 62.2 when installed with 3 way switch and remotely mounted speed control.

Sound

Fan sound levels are measured in sones. At this time there are no sone level test standards available through HVI due to the fact that remote mounted fan noise levels are in proportion to the following: type of duct, length of duct, fan distance from the intake source and other random factors. It is generally accepted that remote mounted venting is usually quieter than standard (in room) venting.



KIT - PV BATHROOM EXHAUST KITS

FEATURING PV-POWERVENT FANS



S&P PV-POWERVENT Series fans are also available as easy-to-install kits. This ultra powerful bathroom fan offers a choice of single or dual vent exhaust. These kits are used for installations that require long or complicated duct runs.

All PV kits have standard 8-year warranty.



PV Deluxe Exhaust Kits



Standard Exhaust Kits



KIT-PV100

- 1 PV100 exhaust fan
- 1 plastic round grille (PG-100)
- Mounting bracket

KIT-PV100x

- 1 PV100x exhaust fan
- 1 plastic round grille (PG-100)
- Mounting bracket

KIT-PV150

- 1 PV150 exhaust fan
- 1 plastic round grille (PG-150)
- Mounting Bracket

KIT-PV100x-DV

- 1 PV100x exhaust fan
- 2 plastic round grilles (PG-100)
- 1 Y-fitting (SY-4)
- Mounting Bracket

KIT-PV150-DV

- 1 PV150 exhaust fan
- 2 plastic round grilles (PG-150)
- 1 Y-fitting (SY-6)
- Mounting Bracket

KIT-PV200-DV

- 1 PV200 exhaust fan
- 2 plastic round grilles (BOR-200)
- 1 Y-fitting (SY-8)
- Mounting Bracket



BATHROOM EXHAUST GRILLES FOR INLINE FANS

Featuring Vent Lights and Premium Grilles

S&P's Grille Options give you the choice of seven (7) aesthetically pleasing grilles designed to match any bathroom decor. You can choose from our Vent Lights, Premium Grilles or Adjustable Grilles to fit your needs.

These grilles are designed to be used exclusively with one of S&P's remotely mounted inline fans (TD, PV, SWF) for virtually silent bathroom ventilation. Inline fans give you the option to mount your grille over the shower, toilet, tub, or in multiple locations (dual vent).

With S&P's Grille Options the choice is yours!

Vent Lights Available with LED Bulbs



S&P's new Vent Lights give you ventilation that is "Out-of-Sight and Out-of-Mind"! The Vent Lights appear to be a regular can light, and when combined with a remotely mounted fan, the noise and unsightly look of the traditional bathroom fan are gone! The Vent Lights are aesthetically pleasing grilles with lights that will match any bathroom decor.

Model	Description
VLED-100	Vent Light with PAR30 LED Bulb
VLH-100	Vent Light with PAR30 Halogen Bulb
VLF-100	Vent Light with Energy Star Rated Compact Fluorescent Bulb

Dimensions (inches)

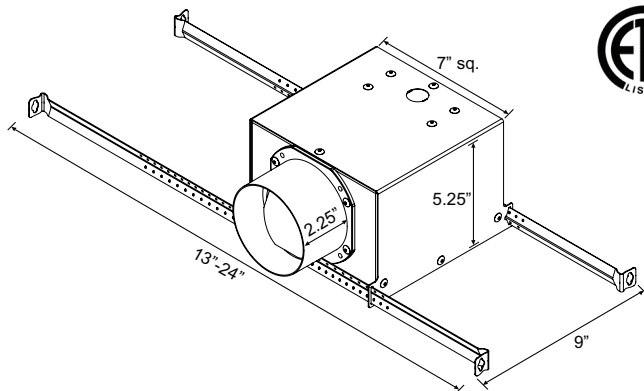

Features:

- Longer duct collar for 4" duct
- Extendable hanger bars up to 24"
- 7.5" grille
- Built-in backdraft damper
- 3 bulb options

Why Choose the Vent Light with LED Bulbs?

S&P's respect for the environment extends to its Vent Lights with the optional LED Bulb. The benefits to the LED Bulbs include:

- Built to last a minimum of 60,000 hours, plus the LED's use a fraction of the energy that a traditional incandescent or halogen lamp uses
- LED's contain no mercury so they are easy to dispose of, unlike other energy efficient bulbs
- The LED lamps run cool and are shock resistant, making them safer for use in your home



Premium Grilles

PG



S&P's premium grilles come standard with steel collars for easy mounting and installation.

Model	Description
PG-100	4" Plastic Grille with 4" Steel Collar
PG-150	6" Plastic Grille with 6" Steel Collar

Grille Dimensions (in inches)



Grille	Dia.	Height	Fits Duct Dia.	Fits Collars
PG-150G	8 1/8	1 5/8	6"	PG-150D
PG-100G	4 5/8	1 1/2	4"	PG-100D

Collar Dimensions (in inches)



Collar	Diameter	Length
PG-100D	3 3/4	3 1/4
PG-150D	5 3/4	4 5/8

PG Collar

Adjustable Grilles

BOR/BOC



Exhaust grilles for bathrooms, toilets and other small rooms. All models offer an adjustable central valve to regulate the airflow.

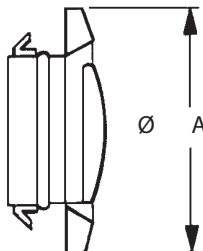
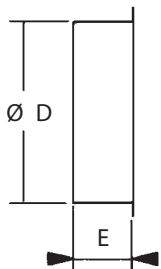

Model	A	D	E	Weight (lbs)
BOR/BOC-100	145	100	50	1
BOR/BOC-125	145	125	50	1
BOR/BOC-150	204	160	50	1
BOR/BOC-200	244	200	50	1



ADDITIONAL GENERAL ASSEMBLY ACCESSORIES



BOR/BOC
Round plastic/metal adjustable grille



PG
Round grille without built-in backdraft damper



MBR
Connection Flanges



PER-W
Plastic louver shutter



PER
High pressure aluminum louver shutter



GRA
Aluminum exterior fixed grilles

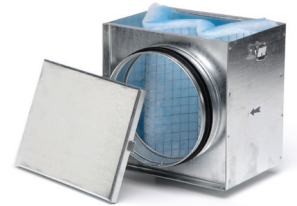

MFL
Filtering Box



SR
Reducer



SY
Y sheet metal adapter



ID
Flexible round duct



SIL
Acoustic attenuators

Electrical accessories



EPBT
Electronic push button timer

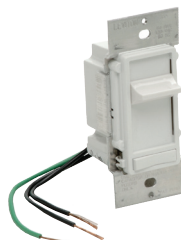

SCS
Speed control slide type



SC
Speed control



KIT - CLOTHES DRYER BOOSTING KITS

FEATURING PV-100x FANS

If you have a dryer with long or complicated duct runs, S&P offers the perfect solution to increase dryer efficiency: the PV100x Dryer Booster Fan. The PV100x has been specifically designed to handle dryer boosting applications when overcoming long or complicated duct runs. This system helps save on drying time, moisture build-up, wear and tear on your dryer, and helps save on your electric bill. The centrifugal blade design is able to overcome extreme resistance from the most challenging installations. The PV-100x offers a fully enclosed motor, which ensures a long, trouble free life; thus making it the right choice for enhancing the performance of your clothes dryer.

The PV-100x fan is available separately or as part of a kit that includes everything necessary for a hands-free operation. Once the system is installed you will no longer waste time, energy or unnecessary wear and tear on your dryer. The next step is to select which activation best fits your needs.

How to activate the PV-100x fan for clothes dryer boosting



NOTE

The PV-100x Dryer Booster fan is suitable for use with duct runs of up to 105 linear feet of 4" rigid duct or a maximum of 6 elbows and 80 feet.



PV-100xps

Pressure Switches

Pressure switches are a viable method of fan activation and a good solution for many installations. The pressure switch senses the pressure differential in the duct created by the dryer operation, thus activating the fan. Conversely, when the dryer is deactivated, the pressure switch senses this differential and the fan is deactivated. S&P's PV-100xps utilizes a compact pressure sensor and run timer enclosed within the junction box and mounted to the fan housing. The pressure sensor is also available as an accessory.



DBF-100xc

Current Sensors

Current sensors are S&P's "preferred" method of activation. They are "fail-safe", as there is no maintenance required on the current sensor and they're easy to install. The current sensing device can be installed at the outlet (where the dryer plugs into the wall) or at the circuit breaker box. When the device senses current going to the dryer, it activates the fan and vice-versa. No thought! No maintenance! Our choice!



IL-115/230

Interlocks

Interlocks, like Current Sensors, are another "fail-safe" method of clothes dryer booster activation. The interlocks senses when the fan is running and activates the dryer. Used as a safety feature, if the fan is not running or if there is a problem with the fan the dryer will not turn on.

All 3 activation methods are available as accessories or in the S&P's all inclusive dryer booster kits.



SWF - Sidewall Mount Exhaust Fan for Dryer Boosting



The sidewall unit can be paired with a current sensor or pressure switch when interior duct access in a home, apartment or townhouse is limited or difficult. The expanded exhaust grille allows for the easy passing of lint laden air. The SWF utilizes the same powerful motor as the PV-100x and is also suitable for duct runs up to 105 feet or up to 80 feet with 6 elbows. The low profile SWF fan is easy to install with an epoxy coating that can be painted to match the exterior of the building. The SWF also offers the same trusted 5 year warranty.

