



**NATIONAL
COMFORT
PRODUCTS**
HEATING & A/C EQUIPMENT

Thru-the-Wall Comfort for all types of Multi-Family Construction

Installation Manual

Comfort Pack Gas
Universal Series

Non Condensing Furnace
80% AFUE

This unit should be installed in an
OUTSIDE WALL for **THRU-THE-WALL
INSTALLATION ONLY!**

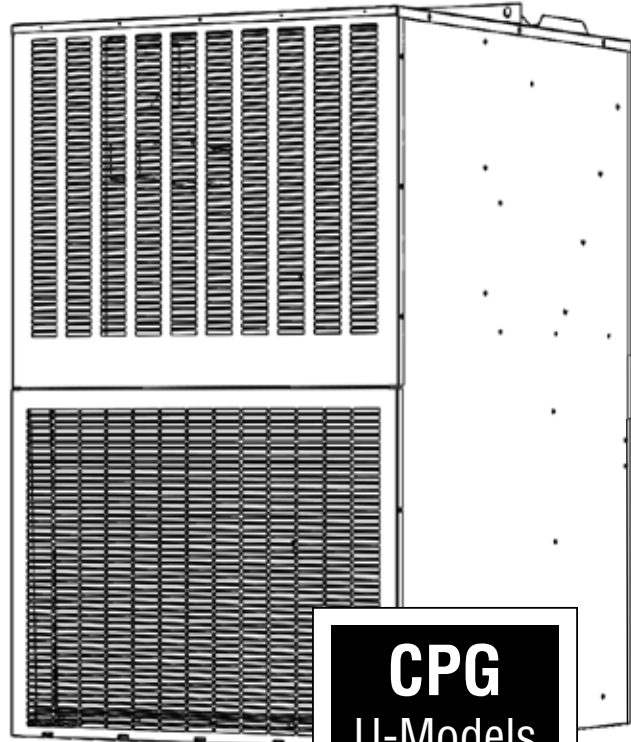

CPG
U-Models
Non
Condensing
Furnace



*Read Installation Manual prior to starting the installation.
This manual must be left with the homeowner for future reference.*

Go Thru-the-Wall



National Comfort Products
A Division of National Refrigeration and Air Conditioning Products, Inc.
539 Dunksferry Road • Bensalem, PA 19020-5908
(800) 523-7138 • Fax (215) 639-1674
www.nationalcomfortproducts.com

Table of Contents

Comfort Pack Nomenclature	page 4
Safety First	page 5-6
Before You Start	page 6
Installation	page 8
Drainage.....	page 8
Clearance	page 9
Unit Location Considerations	page 10
Vent Termination Clearances	page 11
Electrical	page 12-14
Dimensions	page 15
Gas Furnace Specifications	page 16
Sequence of Operations (Gas Heat)	page 16
Abnormal Functions	page 17
High Altitude Operation	page 17-18
Gas Piping, Venting & Pressures	page 19-20
Ignition System.....	page 21
Start up.....	page 22-23
Special Notes for Extremely Cold Weather Areas	page 23-24
Gas Control Valve.....	page 24
Maintenance and Service	page 24-29
Slide Out Furnace Instructions.....	page 29-30
Equipment Specifications.....	page 31
Air Flow	page 32-35
Wiring Diagram	page 36
Trouble Shooting	page 37-38
Replacement Parts Guide	page 39-40
Warranty	page 42-43

**IMPORTANT NOTE: DO NOT DESTROY OR THROW AWAY THIS MANUAL.
IT SHOULD BE KEPT IN A SAFE PLACE FOR FUTURE REFERENCE.**

Installation Manual for Comfort Pack Gas Non Condensing Furnace

Comfort Pack Nomenclature

Note: Standard units (with no options) will have no letter after the “U” in the name. **Example:** CPG41738-U

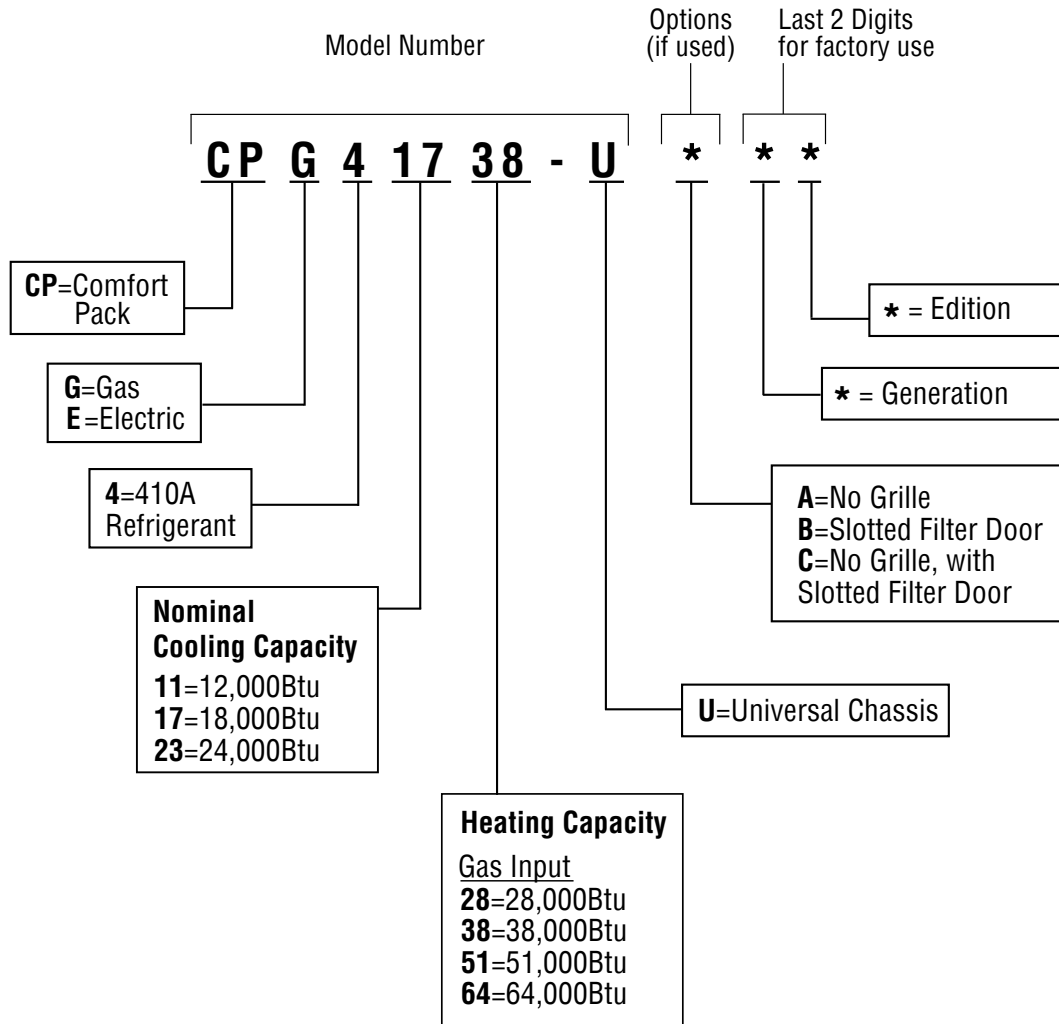

Safety First!

HAZARD INTENSITY LEVELS

1. **DANGER:** FAILURE TO COMPLY WITH WILL RESULT IN SEVERE PERSONAL INJURY OR DEATH AND/ OR PROPERTY DAMAGE.
2. **WARNING:** FAILURE TO COMPLY COULD RESULT IN SEVERE PERSONAL INJURY OR DEATH AND/ OR PROPERTY DAMAGE.
3. **CAUTION:** FAILURE TO COMPLY COULD RESULT IN MINOR PERSONAL INJURY AND/OR PROPERTY DAMAGE.

WARNING

FOR YOUR SAFETY, DO NOT STORE OR USE GASOLINE OR OTHER FLAMMABLE VAPORS AND LIQUIDS IN THE VICINITY OF THIS OR ANY OTHER APPLIANCE. SUCH ACTIONS COULD RESULT IN PROPERTY DAMAGE, PERSONAL INJURY, OR DEATH.

CAUTION

SHOULD OVERHEATING OCCUR, OR THE GAS SUPPLY FAIL TO SHUT OFF, SHUT OFF THE MANUAL GAS VALVE TO THE APPLIANCE BEFORE SHUTTING OFF THE ELECTRICAL SUPPLY.

WARNING

WARNING: DO NOT USE THIS APPLIANCE IF ANY PART HAS BEEN UNDER WATER. IMMEDIATELY CALL A QUALIFIED SERVICE TECHNICIAN TO INSPECT THE APPLIANCE AND REPLACE ANY GAS CONTROL THAT HAS BEEN UNDER WATER.

WARNING

INSTALLATION AND REPAIR OF THIS UNIT SHOULD BE PERFORMED ONLY BY INDIVIDUALS MEETING THE REQUIREMENTS OF AN "ENTRY LEVEL TECHNICIAN" AS SPECIFIED BY NATIONAL CODES. ATTEMPTING TO INSTALL OR REPAIR THIS UNIT WITHOUT SUCH BACKGROUND MAY RESULT IN PRODUCT DAMAGE, PERSONAL INJURY OR DEATH.



WARNING

HIGH VOLTAGE!
DISCONNECT ALL POWER BEFORE SERVING. FAILURE TO DO SO MAY RESULT IN PROPERTY DAMAGE, PERSONAL INJURY OR DEATH.

CAUTION

USE CARE WHEN HANDLING SCROLL COMPRESSORS. SOME TEMPERATURES COULD BE HOT!

CAUTION

SCROLL COMPRESSORS SHOULD NEVER BE USED TO EVACUATE THE AIR CONDITIONING SYSTEM. VACUUMS THIS LOW CAN CAUSE INTERNAL ELECTRICAL ARCING RESULTING IN A DAMAGED OR FAILED COMPRESSOR.

WARNING

THE UNIT MUST BE PERMANENTLY GROUNDED. FAILURE TO DO SO CAN CAUSE ELECTRICAL SHOCK RESULTING IN SEVERE PERSONAL INJURY OR DEATH.

"USE COPPER SUPPLY WIRES ONLY"

WARNING

IF THE INFORMATION IN THIS MANUAL IS NOT FOLLOWED EXACTLY, A FIRE OR EXPLOSION MAY RESULT CAUSING PROPERTY DAMAGE, PERSONAL INJURY OR LOSS OF LIFE.

Do **NOT** store or use gasoline or other flammable vapors and liquids in the vicinity of this or any other appliance.

WHAT TO DO IF YOU SMELL GAS:

- Do **NOT** try to light any appliance.
- Do **NOT** touch any electrical switch; do not use any phone in your building.
- Immediately call your gas supplier from a neighbor's phone. Follow the gas supplier's instructions.
- If you cannot reach your gas supplier, call the fire department.

Installation and service **must** be performed by a qualified installer, service agency or the gas supplier.

WARNING

IMPROPER INSTALLATION, ADJUSTMENT, ALTERATION, SERVICE, OR MAINTENANCE CAN CAUSE PROPERTY DAMAGE, PERSONAL INJURY OR LOSS OF LIFE. REFER TO THE USER'S INFORMATION MANUAL PROVIDED WITH THIS FURNACE. INSTALLATION AND MATERIALS, SERVICE MUST BE PERFORMED BY A QUALIFIED INSTALLER, SERVICE AGENCY OR THE GAS SUPPLIER.

This furnace must be installed in accordance with the manufacturer's instructions and local codes. In the absence of local codes, follow the National Fuel Gas Code, ANSI Z223.1 or the CAN/CGA-B149 Installation Codes.

To be installed without alteration.

Installation Manual for Comfort Pack Gas Non Condensing Furnace

Safety First!

WARNING

IF ANY OF THE ORIGINAL WIRE AS SUPPLIED WITH THE FURNACE MUST BE REPLACED, IT MUST BE REPLACED WITH WIRING MATERIAL HAVING A TEMPERATURE RATING OF AT LEAST 90°C.

THIS FURNACE MUST BE INSTALLED SO THERE ARE PROVISIONS FOR VENTILATING AIR.

SHOULD OVERHEATING OCCUR, OR THE GAS SUPPLY FAIL TO SHUT OFF, SHUT OFF THE MANUAL GAS VALVE TO THE FURNACE BEFORE SHUTTING OFF THE ELECTRICAL SUPPLY.

CAUTION

THESE UNITS ARE NOT APPROVED FOR MOBILE HOME APPLICATIONS. SUCH USE COULD RESULT IN PROPERTY DAMAGE, PERSONAL INJURY, OR DEATH.

WARNING

THESE INSTRUCTIONS ARE INTENDED AS AN AID TO QUALIFIED, LICENSED SERVICE PERSONNEL FOR PROPER INSTALLATION, ADJUSTMENT AND OPERATION OF THIS UNIT. READ THESE INSTRUCTIONS THOROUGHLY BEFORE ATTEMPTING INSTALLATION OR OPERATION. FAILURE TO FOLLOW THESE INSTRUCTIONS MAY RESULT IN IMPROPER INSTALLATION, ADJUSTMENT, SERVICE OR MAINTENANCE POSSIBLY RESULTING IN FIRE, ELECTRICAL SHOCK, PROPERTY DAMAGE, PERSONAL INJURY OR DEATH.

WARNING

DO NOT USE OXYGEN TO PURGE LINES OR PRESSURIZE SYSTEM FOR LEAK TEST. OXYGEN REACTS VIOLENTLY WITH OIL, WHICH CAN CAUSE AN EXPLOSION RESULTING IN SEVERE PERSONAL INJURY OR DEATH.

WARNING

GAS-FIRED APPLIANCES ARE NOT DESIGNED FOR USE IN HAZARDOUS ATMOSPHERES CONTAINING FLAMMABLE VAPORS OR COMBUSTIBLE DUST, IN ATMOSPHERES CONTAINING CHLORINATED OR HALOGENATED HYDROCARBONS, OR IN APPLICATIONS WITH AIRBORNE SILICONE SUBSTANCES. SEE HAZARD LEVELS BELOW.

Before You Start

This unit is shipped with a cooling chassis installed in the cabinet. Prior to installing the unit in the wall opening, the shipping bolts located at the bottom on both sides of the cabinet must be removed to allow for removal of the cooling chassis. 1/4" hole plugs provided with the unit should be installed in the holes to prevent air leakage. Shipping bolts are located on both sides below this sticker:

THE SHIPPING BOLTS MUST BE REMOVED PRIOR TO INSTALLATION OF THE CABINET TO PERMIT REMOVAL OF THE CHASSIS. INSTALL THE HOLE PLUGS PROVIDED.



14299588

This unit is designed and approved for through-the-wall installation only. The unit must be installed a minimum of 8" above finish floor. If this unit is installed in a residential garage, it must be installed so that the ignition source and burners are located not less than 18 inches (457 mm) above the floor, and it must be located or protected to avoid physical damage by vehicles. The entire unit must not be installed outside. The grille side of the unit should extend 3/4" beyond the exterior wall to allow moisture that may enter the outdoor section to drain. The pitch of the internal drain pans toward the outside will assure proper drainage when the cabinet is installed level. **Masonry walls must have a lintel to support the wall.**

The interior of the unit may be installed with zero clearances to adjacent combustibile surfaces. **The unit shall not be installed directly on carpeting, tile or other combustibile material, except wood flooring.** In order to be able to remove the chassis, 29" of open area must be left unobstructed in front of the access panels. The 3/4" O.D. drain pan connection should be connected to the building drain using the flexible tubing included and a trap. The secondary drain offers protection from overflow. The secondary drain feature is piped into the base of the unit and drains through the weep holes outside. Reconnect 3" piece of clear flexible tubing to secondary drain on drain pan. Position secondary drain through grommet of chassis and connect to flexible tubing (prime trap prior to operating).

The grille side must be kept free of any obstructions that will reduce or alter the air flow pattern. **The unit must be installed at least 4 feet (1.22 m) from electric meters, gas meters, regulators, and relief equipment. The vent of the unit is located at the front grille. Distances from adjacent public walkways, adjacent buildings, openable windows, and building openings must be consistent with the National Fuel Gas Code ANSI Z223.1 and/or CAN/CGA-B149 installation codes, as well as local codes.**

If an optional architectural grille is to be used on standard units, the stamped and louvered grille provided **must** be removed. Consult the factory prior to ordering product(s) that require an optional architectural grille.



CAUTION

THE INSTALLATION OF THIS APPLIANCE MUST CONFORM TO THE REQUIREMENTS OF THE NATIONAL FIRE PROTECTION ASSOCIATION; THE NATIONAL ELECTRIC CODE, ANSI/NFPA NO. 70 (LATEST EDITION) IN THE UNITED STATES; THE CANADIAN ELECTRICAL CODE PART 1, CSA 22.1 (LATEST EDITION) IN CANADA; AND ANY STATE OR PROVINCIAL LAWS OR LOCAL ORDINANCES. LOCAL AUTHORITIES HAVING JURISDICTION SHOULD BE CONSULTED BEFORE INSTALLATION IS MADE. SUCH APPLICABLE REGULATIONS OR REQUIREMENTS TAKE PRECEDENCE OVER THE GENERAL INSTRUCTIONS IN THE MANUAL.

TO REMOVE THE CHASSIS FROM THE CABINET:

TURN OFF POWER TO THE UNIT. REMOVE THE LOWER ACCESS PANEL FROM THE CABINET. DISCONNECT THE DRAIN LINE FROM THE EVAPORATOR COIL DRAIN CONNECTION. DISCONNECT THE SECONDARY DRAIN FLEXIBLE TUBING & TRAP TO AVOID DAMAGE (PRIME TRAP WHEN REINSTALLING). DEPRESS AND HOLD THE RELEASE LATCH ON THE CHASSIS POWER WIRING CONNECTOR AND UNPLUG IT FROM THE CABINET POWER WIRING CONNECTOR. DEPRESS AND HOLD THE RELEASE LATCH ON THE CONTROL WIRING CONNECTOR AND UNPLUG IT FROM THE CABINET CONTROL WIRING CONNECTOR.

REMOVE THE SCREWS ATTACHING THE CONTROLS ENCLOSURE TO THE INDOOR COIL COVER. REMOVE THE SCREWS FROM THE INDOOR BLOWER COVER PLATE. REMOVE THE PLATE FROM THE UNIT. TEMPORARILY SECURE THE CHASSIS POWER AND CONTROL WIRING AND CONNECTORS TO THE TOP OF THE INDOOR COIL COVER TO PREVENT DAMAGE DURING CHASSIS REMOVAL.

CAREFULLY SLIDE THE CHASSIS OUT OF THE CABINET BY GRASPING BOTH SIDES OF THE EVAPORATOR COIL DRAIN PAN AND PULLING TOWARD YOU WHILE KEEPING THE CHASSIS CENTERED IN THE CABINET. AS THE CHASSIS IS REMOVED, KEEP THE CHASSIS LEVEL UNTIL THE OUTDOOR FAN COVER PASSES THE CABINET SEALS. **DAMAGE TO THE CABINET SEALS WILL RESULT IF THE CHASSIS IS NOT KEPT LEVEL UNTIL THE OUTDOOR FAN COVER HAS PASSED THE CABINET SEALS.** AFTER THE CHASSIS IS REMOVED, IT SHOULD BE HANDLED USING

THE CHASSIS BASE AND EVAPORATOR DRAIN PAN, NOT BY USING REFRIGERANT PIPING OR THE OUTDOOR FAN MOUNT. THE BOTTOM OF THE CHASSIS IS NOT SMOOTH AND WILL DAMAGE FLOORS IF SLID.

TO INSTALL THE CHASSIS INTO THE CABINET:

TURN OFF POWER TO THE UNIT. TEMPORARILY SECURE THE CHASSIS POWER AND CONTROL WIRING AND TURN OFF POWER TO THE UNIT. TEMPORARILY SECURE THE CHASSIS POWER AND CONTROL WIRING AND CONNECTORS TO THE TOP OF THE INDOOR COIL COVER TO PREVENT DAMAGE DURING CHASSIS INSTALLATION. PLACE THE OUTDOOR COIL SECTION OF THE CHASSIS ONTO THE CABINET RAILS. LIFT THE REAR OF THE CHASSIS USING THE EVAPORATOR COIL DRAIN PAN SO THAT THE CHASSIS IS LEVEL AND CENTERED AS IT IS PUSHED IN THE CABINET. **DAMAGE TO THE CABINET SEALS WILL RESULT IF THE CHASSIS IS NOT KEPT LEVEL UNTIL THE OUTDOOR FAN COVER HAS PASSED THE CABINET SEALS, AND THE CHASSIS KEPT CENTERED IN THE CABINET.** AFTER THE CHASSIS IS ALL THE WAY IN THE CABINET, CHECK THAT THE CHASSIS IS CENTERED IN THE CABINET BY VERIFYING THAT IT IS IN CONTACT WITH THE CABINET SEALS ON BOTH SIDES.

INSTALL THE INDOOR BLOWER COVER PLATE AND SECURE IT WITH SCREWS. INSTALL THE CHASSIS POWER WIRE CONNECTOR AND THE CONTROL WIRING CONNECTOR INTO THEIR RESPECTIVE CABINET WIRING CONNECTORS SO THAT THE CONNECTORS LATCH. POSITION THE CONTROLS ENCLOSURE AND SECURE IT TO THE INDOOR COIL COVER WITH SCREWS. CONNECT THE DRAIN LINE TO THE EVAPORATOR COIL DRAIN CONNECTION. RECONNECT 3" PIECE OF CLEAR FLEXIBLE TUBING TO SECONDARY DRAIN ON DRAIN PAN. POSITION SECONDARY DRAIN THROUGH GROMMET OF CHASSIS AND CONNECT TO FLEXIBLE TUBING (PRIME TRAP PRIOR TO OPERATING). INSTALL THE LOWER ACCESS PANEL ON THE CABINET. TURN ON POWER TO THE UNIT.

ALL phases of this installation must comply with NATIONAL, STATE AND LOCAL CODES. The manufacturer assumes no responsibility for equipment installed in violation of any code requirements.

Be sure that the electrical data specified on the unit rating plate corresponds to what is available at the installation site and NEC for installation requirements.

This unit MUST be installed in an outside wall for thru-the-wall installation ONLY.

Installation Manual for Comfort Pack Gas Non Condensing Furnace

Be sure that the electrical service provided to the building can handle the load imposed by the unit.

IMPORTANT — This Document is customer property and is to remain with this unit. Please refer to service information pack upon completion of work to register the unit's warranty. These instructions do not cover all variations in systems or provide for every possible contingency to be met in connection with the installation. Should further information be desired or should particular problems arise which are not covered sufficiently for the purchaser's purposes, the matter should be referred to your installing dealer or local distributor before contacting the manufacture.

NOTE: THE UNIT MUST NEVER BE PLACED ON ITS SIDE OR UPSIDE DOWN AS THE COMPRESSOR OIL WILL RUN IN THE COOLING CIRCUIT AND SERIOUSLY DAMAGE THE UNIT.

Installation

NOTE: THESE INSTALLATION AND MAINTENANCE INSTRUCTIONS SHOULD BE LEFT WITH THE UNIT FOR FUTURE REFERENCE.

This unit must be installed in accordance with all applicable codes. This unit is not to be used for temporary heating of buildings or structures under construction.

FOR MAXIMUM PERFORMANCE, IT IS IMPERATIVE THAT THE COOLING CHASSIS AIR DIVIDER BE SEALED TO THE CABINET AIR SEAL. ANY LEAKAGE WILL ALLOW OUTSIDE UNCONDITIONED AIR TO INFILTRATE AND MIX WITH THE CONDITIONED AIR. THIS CONDITION WILL DEGRADE UNIT PERFORMANCE. ALL UNITS SHOULD BE INSPECTED FOR THIS CONDITION, AS DURING TRANSPORTATION AND INSTALLATION THE SEALS CAN BE DISTURBED. IF REQUIRED, A LIGHT BEAD OF CAULKING IS RECOMMENDED TO SEAL THE CHASSIS, TO THE AIR SEAL TO ELIMINATE LEAKAGE.

OUTSIDE/UNCONDITIONED AIR MUST NOT BE INTRODUCED INTO THE RETURN AIR STREAM OF THIS UNIT. THIS CONDITION WILL ALSO DEGRADE THE PERFORMANCE OF THE UNIT AND MAY VOID EQUIPMENT WARRANTY.

The unit should be provided with support inside the building in the area of the return air opening. The support should be high enough to allow for return air provisions to the unit. To reduce

the possible transmission of sound and vibration, a resilient material such as rubber or cork should be installed between the support and the base of the unit. All spaces around the top, sides and bottom of the exterior grille area should be caulked and sealed to the wall, making sure that the openings for drainage in the bottom edge are not blocked.

If the optional wall sleeve is used, caulk the spaces between the sleeve and the wall. Completely fill the clearance on all sides between the unit and the wall sleeve with a polyurethane foam sealant (follow manufacturer's suggested application manual). Provide the unit with support inside the building in the area of the return air opening. Slide the unit into the wall sleeve and fasten the unit to the sleeve with the five screws provided with the sleeve.

NOTE: FOR EASE OF INSTALLATION, INSTALL THE CABINET INTO THE WALL SLEEVE FIRST WITHOUT THE COOLING CHASSIS. THEN SLIDE COOLING CHASSIS IN AFTER CABINET IS IN PLACE.

Drainage

The 3/4" I.D. flexible tubing included should be connected to the Comfort Pack primary drain connection so that it can easily be disconnected if the cooling chassis must be removed. A trap at least 2" deep should be provided close to the drain pan. The tubing should not be higher than the bottom of the unit drain pan at any point to assure proper drainage and allow chassis removal. The drain line should pitch downward at least 1" per 10 ft. to an open building drain trap.

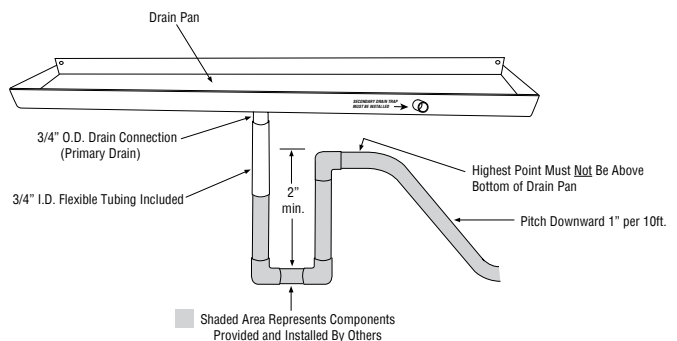

Installation Manual for Comfort Pack Gas Non Condensing Furnace

Secondary Drain Trap Install Instructions:

1. The trap and 2" piece of clear flexible 1/2" ID tubing are shipped loose to prevent damage. They should be installed after the Comfort Pack unit is installed and the return air connection completed.
2. The trap must be primed (filled with water) for proper operation of the secondary drain system. This may be done prior to installation of the trap or after.
3. Insert trap into the grommet located in chassis base pan.
 - a. Apply force to section 1 (refer to drawing below)
 - b. Ensure at least .5" - 0.75" of tubing is inserted into the grommet
 - c. PVC should be flush with drain pan connection

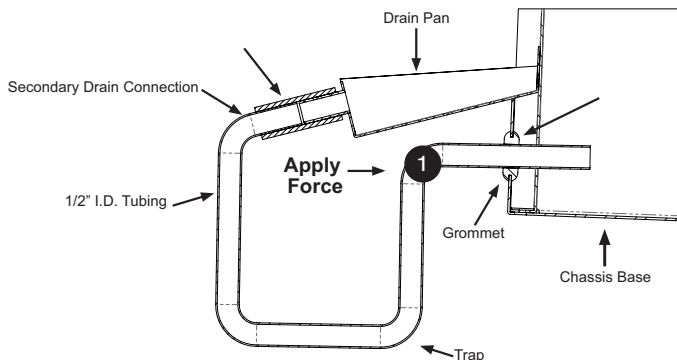
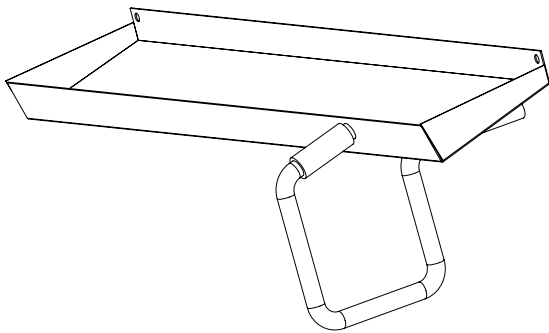

4. Position the trap as shown and slide the 2" piece of clear flexible tubing about 1" onto the top end of the trap. Slide the top of the flexible tube on the trap onto the bottom of the 1/2" OD secondary drain connection and push the top of the trap up. The trap should be positioned so that there is only a small gap between the top of the trap and the bottom of the secondary drain connection.

5. To avoid damage whenever the slide-out chassis has to be removed from the cabinet, remove the secondary drain trap before sliding the chassis out. After the chassis is reinstalled in the cabinet, prime the trap with water before reinstalling it.

Clearances

For proper unit performance and maximum operating life please maintain the following minimum installation clearances.

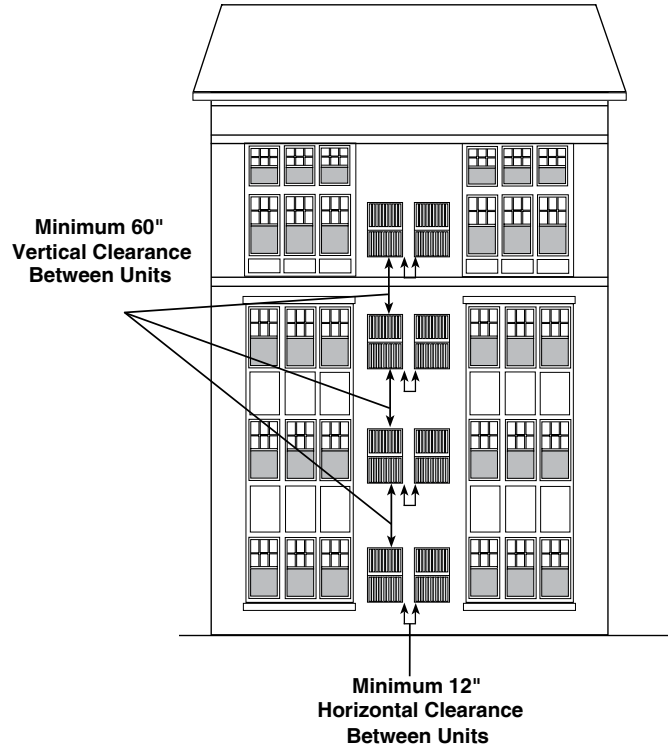

*Less than 12" Call National Comfort Products

Comfort Pack units must be installed through an outside wall. Confined spaces and/or covered areas should be avoided. Consult the factory if unclear of clearances required. Units must be installed a minimum of **12"** apart when two units are side by side. If three or more units are to operate next to one another, allow a minimum of **60"** between units or pairs of units. Also, a vertical clearance of **60"** should be maintained between units. Units installed on the bottom floor should be mounted at least **8"** off of the ground.

The unit is designed and approved for thru the wall installation only. The unit must be installed a minimum of **8"** above a finished floor. If the unit is installed in a residential garage, it must be installed so that the ignition source and burners are located not less than **18"** above the floor, and it must be located or protected to avoid physical damage by vehicles.

Unit Location Considerations

In thru-the-wall installation, due to the various types of wall construction, it is not possible to provide detailed instructions. The following is a list of general requirements and cautions for installing these units.

The unit must be installed level, both - top front to back and left to right.

1. Masonry walls must have a lintel to support the wall.
2. Extend the unit approximately 3/4" beyond outside surface of the wall. Optional mounting angles can be purchased from the factory or field fabricated for locating and mounting the unit in the wall.
3. The wall opening across the top and bottom must be flashed.
 - a. During periods of rain and wind the primary drainage path may not be adequate to handle the load. Secondary precautions may also be required but not limited to the following:
 - Seal flashing to unit
 - Floor drain
 - Additional field sealing of sheet metal joints
 - Sealing of unused access opening
4. Clearances to air inlets and outlets must be adequate to ensure no air flow obstructions or recirculation of condenser air flow.
5. Some architectural designs of buildings will require the unit to be mounted behind a decorative grille. The performance (capacity and efficiency) of the unit may be reduced with the use of these decorative grilles. The less resistive these grilles are to air flow, the better the units performance will be. Outdoor louvers provided by others must be approved by NCP to maintain unit performance and warranty. **Care must be taken to locate the condenser coil away from loose debris that may clog intake.**

6. If the unit is mounted behind a decorative grille, one or both of the following items must be done to eliminate recirculation of air to the unit:

- a. The front of the unit must be mounted tight to the inside of the architectural grille
- b. A barrier must be provided to prevent recirculation of air to the unit (mixing of inlet and outlet air) when the front of the unit is mounted back from the inside of the architectural grille

7. The unit must not be mounted in dead-end hallways or areas where there is no fresh outside air circulation. Cool fresh outside air must be provided for best unit operation. Thru-the-wall units may not be located where hot exhausts from clothes dryer vents, kitchen vents, steam vents or corrosive fumes could come in contact with coil side of unit.

8. 29" clearance is required for service accessibility on the inside service panel.

9. If more than one unit is to be installed in the same area a min. of 60" vertical must be maintained between units to minimize recirculation of condenser exhaust air.

10. Care must be taken when locating the unit. Locate away from bedrooms as operational sounds may be objectionable.

*For other clearance information see page 19.

Installation Manual for Comfort Pack Gas Non Condensing Furnace

Vent Termination Clearances for Direct Vented Installations in the USA

For other gas venting information see page 19.

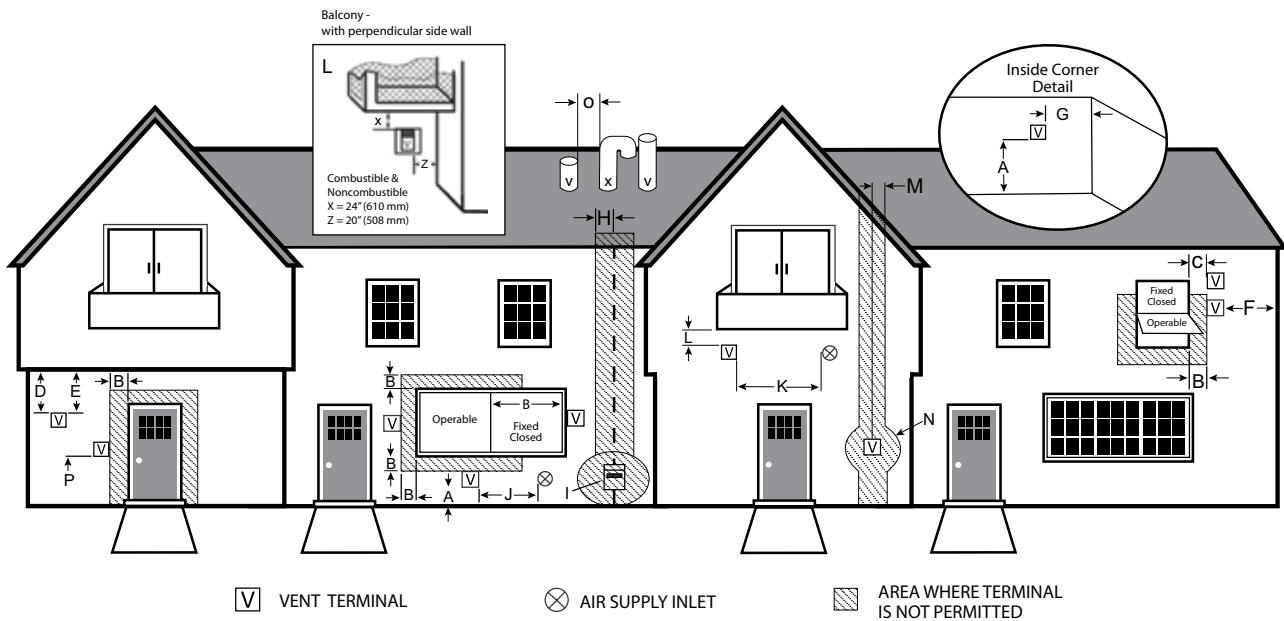

Item	Clearance Description	US Installations (per ANSI Z223.1/NFPA 54)
A	Clearance above grade, veranda, porch, balcony or anticipated snow level	12 in.
B	Clearance to a window or door that may be opened	9 in. for appliances > 10,000 Btuh (3 kW) and ≤ 50,000 Btuh (15 kW), 12in. for appliances > 50,000 Btuh (15 kW)
C	Clearance to a permanently closed window	For clearances not specified in ANSI Z223.1/NFPA 54, clearances shall be in accordance with local installation codes and the requirements of the gas supplier and the manufacturer's installation instructions.
D	Vertical clearance to a ventilated soffit located above the terminal within a horizontal distance of 2 feet from the center line of the terminal	
E	Clearance to an unventilated soffit	
F	Clearance to an outside corner	
G	Clearance to an inside corner	See Note 1
H	Clearance to each side of the center line extended above electrical meter or gas service regulator assembly	3 feet within 15 feet above the meter/regulator assembly.
I	Clearance to service regulator vent outlet	See Note 2
J	Clearance to non-mechanical air supply inlet to building or the combustion air inlet to any other appliance	9 in. for appliances > 10,000 Btuh (3 kW) and ≤ 50,000 Btuh (15 kW), 12in. for appliances > 50,000 Btuh (15 kW)
K	Clearance to a mechanical air supply inlet	3 feet
L	Clearance under a veranda, porch, deck, or balcony	Note 1 & 2
M	Clearance to each side of the center line extended above or below vent terminal of the furnace to a dryer or water heater vent, or other appliance's vent intake or exhaust	12in.
N	Furnace combustion air intake clearance to a water heater vent, dryer or other types of appliance exhausts	3 feet
O	Clearance from a plumbing vent stack	3 feet
P	Clearance above paved sidewalk or paved driveway located on public property	See Note 1 & 2.

Note: This table is based upon National codes for gas appliances, and are provided as a reference. Refer to Local codes which may supersede the standards and/or recommendations.

Note 1: Avoid venting under a deck or large overhang. Recirculation could occur and cause performance or system problems. Ice build-up may occur.

Note 2: For clearances note specified in ANSI Z223.1/NFPA 54, clearances shall be in accordance with local installation codes and the requirements of the gas supplier and the manufacturer's installation instructions.

The vent for this appliance shall not terminate. **a.** Near the soffit vents or crawl space vents or other areas where condensate or vapor could create a nuisance or hazard or property damage; or **b.** Where condensate vapor could cause damage or could be detrimental to the operation of regulators, relief valves, or other equipment.

Specifications for venting subject to change without notice.

Installation Manual for Comfort Pack Gas Non Condensing Furnace

Electrical

All wiring must be installed in accordance with applicable codes.

The unit is factory wired for 230/1/60 power. For 208/1/60 power systems, the wiring to the primary side of the control transformer should be changed from the 240-volt connection to the 208-volt connection to provide proper operation of the control system.

The operating voltage of the unit is from 197 to 253 volts. Operating the equipment outside of these limits will void the warranty.

Electrical Supply and Connections

All electrical wiring and connections, including electrical grounding must be made in accordance with the National Electric Code ANSI/NFPA No. 70 (latest edition) or, in Canada, the Canadian Electrical Code, Part I-C.S.A. Standard C22.1. In addition, the installer should be aware of any local ordinances or utility company requirements that might apply.

Check the rating plate for the supply voltage and current requirements. A dedicated line voltage supply with fused disconnect switch should be run directly from the main electrical panel to the unit. All external wiring must be within approved conduit and have a minimum temperature rise rating of 60°C. Conduit from the disconnect switch must be run so as not to interfere with the service panels.

Controls

Field wiring between the unit and the wall thermostat (by others) may be low voltage for Class 2 systems. The location of the wall thermostat should be 4 to 5 feet above the floor and carefully selected so that the thermostat senses the temperature of the largest conditioned area, without being influenced by drafts, sun exposure or outside temperature.

Electrical Connections

NOTE: Make certain that the volts, hertz, and phase correspond to that specified on the unit rating plate, and that the service provided by the utility is sufficient to handle the additional load imposed by this equipment.

Make all electrical connections in accordance with the National Electrical Code and any pertinent local codes or ordinances. Use a separate branch electrical circuit for this unit. Locate a disconnecting means within sight of and readily accessible to the unit.

- Line Voltage Connections
- Connect the single phase power supply to unit fuse blower terminal L1 and L2
- Connect ground wire to lug
- Low Voltage Connections

When locating the room thermostat, it should be in the natural circulating path of room air. Avoid locations where the thermostat would be exposed to cold air infiltration; drafts from windows, doors or other openings leading to the outside; exposure to air currents from warm-or-cold air registers or to exposure where the natural circulation of the air is cut off, such as behind doors, above or below mantels, shelves, etc.

Electrical - High Voltage

NOMINAL VOLTAGE	MINIMUM VOLTAGE	MAXIMUM VOLTAGE
208-230	197	253

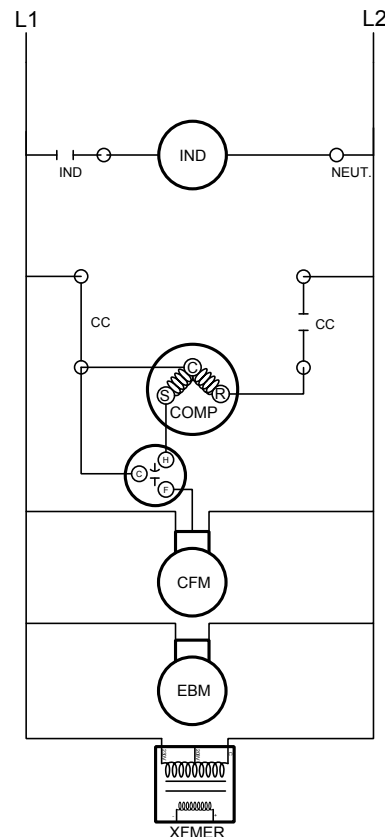

High Voltage Power Supply



WARNING

LIVE ELECTRICAL COMPONENTS!

During installation, testing, servicing and troubleshooting of this product, it may be necessary to work with live electrical components. Failure to follow all electrical safety precautions when exposed to live electrical components could result in death or serious injury.

The high voltage power supply must agree with the equipment nameplate.

OR

Make certain that the volts, hertz, and phase correspond to that specified on the unit rating plate, and that the service provided by the utility is sufficient to handle the additional load imposed by this equipment.

Power wiring must comply with national, state, and local codes.

Follow instructions on unit wiring diagram located on the inside of the access door, or cabinet and in the wiring diagrams included with the unit.

Install a separate disconnect switch at the location of the thru the wall unit.

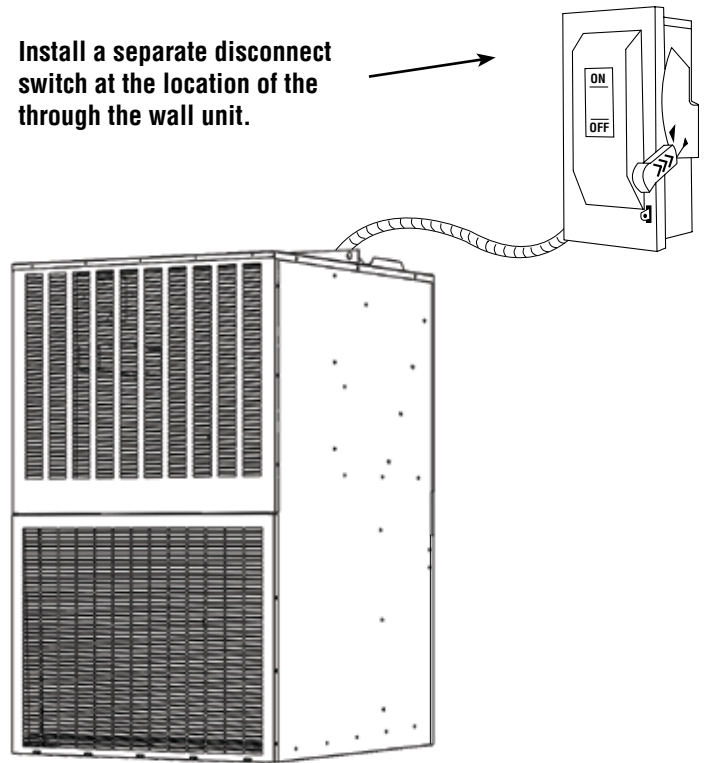

**Thru-the-Wall
Comfort Pack (CPG) Unit**

Electrical - Low Voltage

Low Voltage Maximum Wire Length

Table defines the maximum total length of low voltage wiring from the outdoor unit, to the indoor unit and to the thermostat.

24 VOLTS	
WIRE SIZE	MAX. WIRE LENGTH
18 AWG	150 Ft.
16 AWG	225 Ft.
14 AWG	300 Ft.

Installation Manual for Comfort Pack Gas Non Condensing Furnace

DSI Control Identification - U*3 Versions

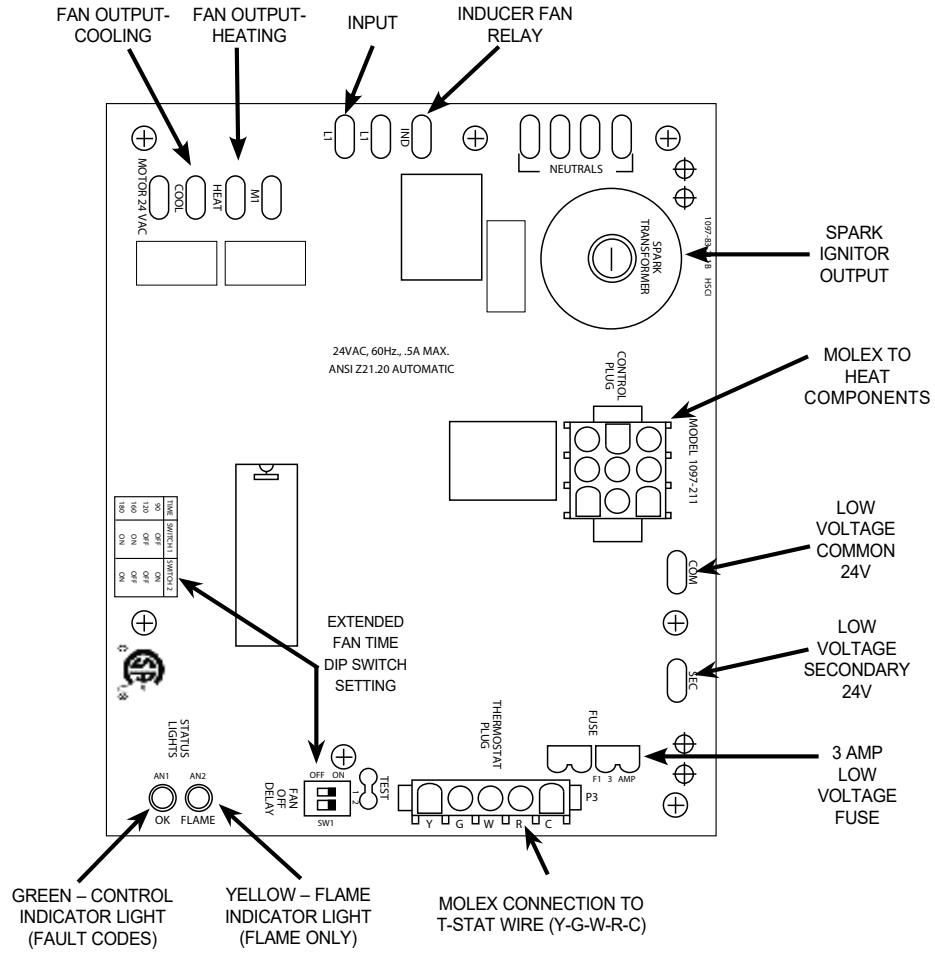

Installation Manual for Comfort Pack Gas Non Condensing Furnace

Comfort Pack Dimension Drawing

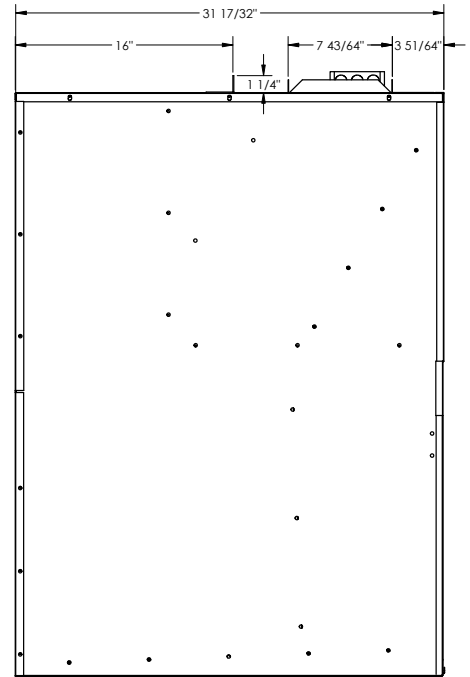
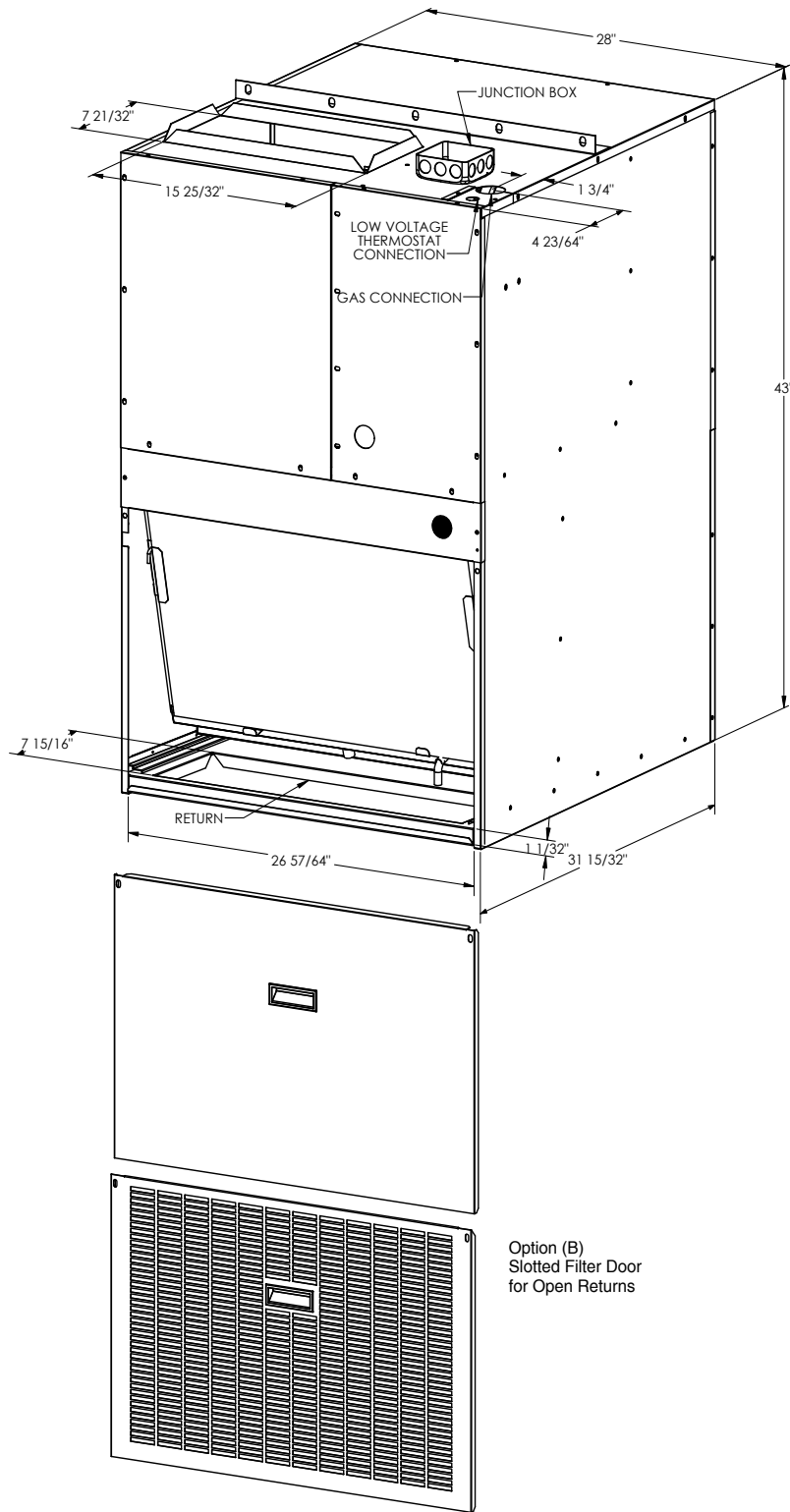

Side view

Option (B)
Slotted Filter Door
for Open Returns

Gas Furnace Specifications

Gas Heat – The cabinet includes a gas furnace with integral flue duct, direct spark ignition, safety controls, and operating controls. The installation of the unit and gas piping must be in accordance with local codes.

Gas Valve Setting 3.5" w.c.

HEAT MODULE	14208378	14208379	14208380	14208381
INPUT BTUH	28,000	38,000	51,000	64,000
OUTPUT BTUH	22,400	30,400	40,800	51,200
MAXIMUM EXTERNAL STATIC PRESSURE	.5" W.C.	.5" W.C.	.5" W.C.	.5" W.C.
DISCHARGE TEMPERATURE RISE RANGE	45°F to 60°F	45°F to 60°F	45°F to 65°F	60°F to 80°F
BLOWER SPEED SETTING	Low* (5-Orange)	Med. Low* (4-Black)	Med. High* (2-Yellow)	High* (1-Red)
*See Wiring Diagrams on Page 36-38.				
To ensure safe operation and long life of the heat exchanger, the maximum static pressure and/or maximum temperature rise must not be exceeded. Operation of the heater at conditions that exceed the heater's specifications will void the heat exchanger warranty				
MODEL SIZE	28	38	51	64
ORIFICE SIZE N.G.	#39	#31	#28	#22
ORIFICE SIZE L.P.	#53	#49	2.1 mm	#41
NOMINAL TEMPERATURE RISE	52.5°F	52.5°F	55°F	67°F
ALLOWABLE AIR TEMPERATURE RANGE	145-160	140-160	140-160	135-160
CO ² %- ACCEPTABLE RANGE	3.2 to 3.6	4.5 to 5.2	4.8 to 5.8	4.5 to 5.5
CO AIR FREE - PPM	0 - 200	0 - 200	0 - 200	0 - 200
SENSING COLD	1.3+/- .1	1.05 +/- .1	1.05 +/- .1	1.05 +/- .1
PRESSURE HOT	.95+/- .05	.8+/- .05	.8+/- .05	.8+/- .05
EFFICIENCY RANGE	80.5% - 81.5%	81.5% - 82.5%	81.5% - 82.5%	80.1% - 81.1%
STACK TEMPERATURE	210°F- 260°F	245°F- 300°F	245°F- 300°F	270°F- 330°F

Temperature Rise Range Based On Return Air Temperature

Sequence of Operations (Gas Heat)

1. Call for Heat – The thermostat sends a call for heat therefore energizing the “white” wire to the control board. The control checks to see that the limit switch is closed and the pressure switch is open. If the limit switch is open, the control responds as defined in the “Limit Switch Operation - page 21”. If the pressure switch is closed, the control will do four flashes on the green LED and wait indefinitely for the pressure switch to open. If the pressure switch is open, the control proceeds to **(2.) Pre-purge**.

2. Pre-purge – The control energizes the venter motor and waits for the pressure switch to close. If the pressure switch does not close within 240 seconds of the venter motor energizing, on 3 attempts ,the control green LED will flash two times and will enter a soft lock out. When the pressure switch is proven closed, the control begins the pre-purge time. If flame is present any time while in pre-purge, the pre-purge time is restarted. If flame is present long enough to cause lockout, the control responds as defined in “Undesired Flame - page 17”. The control runs the venter motor for a 30 second pre-purge time, then proceeds to the **(3.) Ignition Trial Period**.

3. Ignition Trial Period – The control energizes the spark and main gas valve. The venter remains energized. If flame is sensed during the first 16 seconds, the spark is de-energized and the control proceeds to **(4.) Heat Blower On Delay**. If flame has not been sensed during the first 16 seconds, the control de-energizes the spark output and keeps the gas valve energized for an additional one second flame proving period. If flame is not present after the flame proving period, the control de-energizes the gas valve and proceeds with ignition re-tries as specified in “Ignition Retry - page 17”. If flame is present, the control proceeds to the **(4.) Heat Blower On Delay**

4. Heat Blower On Delay – The control waits for 20 seconds from the time the gas valve opened and then energizes the blower motor. The gas valve and venter motor remain energized. The control proceeds to **(5.) Steady Heat**.

5. Steady Heat – The control continuously monitors to the safeties (high limit, roll-out, and pressure) for open switches, flame sensor for proving, and the thermostat for a call for heat. When the thermostat call for heat is removed, the control de-energizes the gas valve and begins **(6.) Post-purge** and **(7.) Blower Off Delay**.

6. Post-purge – The venter motor output remains on for a 30-second post-purge period after the thermostat is satisfied.

7. Blower Off Delay – The blower motor is de-energized after a blower off delay 90 seconds factory setting (field adjustable, see page 14 or 39). Timing begins when the thermostat is satisfied.

Abnormal Functions

- **Interrupted Thermostat Call for Heat** – If the thermostat demand for heat is removed before the flame is recognized, the control will run the venter motor for the post purge period and de-energize all outputs. If the thermostat demand for heat is removed after successful ignition, the control will de-energize the gas valve, run the venter motor through post purge, and run the blower motor on heat speed for the selected delay off time.

- **Soft Lockout** – The control shall not initiate a call for heat or call for continuous fan while in lockout. The control will still respond to an open limit and undesired flame. Lockout shall automatically reset after one hour. Lockout may be manually reset by removing power from the control for more than one second or removing the thermostat call for heat for more than one and less than 20 seconds.

- **Hard Lockout** – If the control detects a fault on the control board, the status LED will be de-energized, and the control will lockout as long as the fault remains. A hard lockout will automatically reset if the hardware fault clears.

- **Power Interruption** – During a momentary power interruption or at voltage levels below the minimum operating voltage for line voltage the system will self-recover without lockout when voltage returns to the operating range. During a momentary power interruption of low voltage the board will enter a soft lockout. Power interruptions of less than 80mS shall not cause the control to change operating states. Power interruptions greater than 80mS may cause the control to interrupt the current operating cycle and re-start.

- **Ignition Retry** – If flame is not established on the first trial for ignition, the control de-energizes the gas valve and the venter motor remains energized for an inter-purge period of 30 seconds. The spark and gas valve are then re-energized, and the control initiates another trial for ignition. If flame is not established on the second trial for ignition, the control de-energizes the gas valve, energizes the blower motor on heat speed, and venter motor remains energized. The blower motor is shut off after a short period. When the blower motor de-energizes, the spark and gas valve are re-energized and the control initiates another trial for ignition. (This blower delay is a self-healing feature for an open auxiliary limit switch). If flame is not established on the third trial for ignition, the control de-energizes the gas valve, and the venter motor remains energized for an inter-purge period of 30 seconds. The control then re-energizes the gas valve and spark and initiates another trial for ignition. If flame is not established on the fourth trial for ignition (initial try plus 3 re-tries), the control de-energizes the gas valve and goes into lockout. The control goes to one flash on the green LED to indicate ignition failure lockout.

Installation Codes

These units must be installed in accordance with local building codes. In the absence of local codes, in the United States, the just be installed in accordance with the National Fuel Gas Code (latest edition). A Canadian installation must be in accordance with the CAN/CGA-B149.1 and B149.2 Installation Code for Gas Burning Appliances and Equipment. These codes are available from GSA Information Services, 1-800-463-6727. Local authorities having jurisdiction should be considered before installation is made to verify local codes and installation procedure requirements.

High Altitude Operation

If the heater is being installed at an elevation above 2000 ft. (610M), the input rate will have to be derated. This is done by adjusting the valve outlet pressure (See page 24). In addition, if the heater is being installed at an altitude above 6000 ft. (1830M), the pressure switch will have to be changed. Adjusting the valve outlet pressure is done after the heater is in operation; follow the instructions below. If the pressure switch needs changed, do that before the heater is operated (see Figure 1).

Figure 1

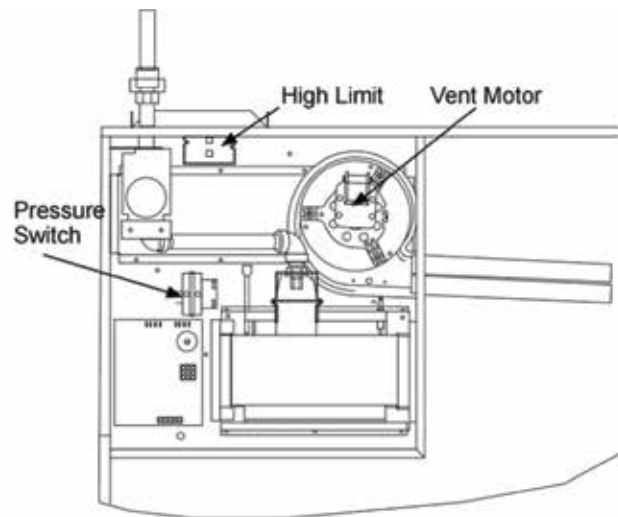

Heat Section Burner/Control Compartment

(Note: Unit side panel is removed for clarity; side panel is not removable. Access to the burner/control compartment is through the small rear access panel.)

Installation Manual for Comfort Pack Gas Non Condensing Furnace

Instructions for Changing Pressure Switch

1. Open the burner/control compartment access panel. Locate the pressure switch.
2. Mark and disconnect the two wires attached to the pressure switch.
3. Disconnect the flow sensing tubing from the pressure switch.
4. Locate the two screws holding the switch mounting bracket. Remove the screws (save screws) and the pressure switch.
5. Install the high altitude pressure switch. Attach the sensing tube and wires. Replace access panel.

SIZE	P/N	DESCRIPTION
ALL	14208325	Set to break on pressure increase @ -0.5" w.c.

Derating by Valve Outlet Pressure Adjustment for High Altitude Operation

Instructions

1. Determine the required valve outlet pressure for the elevation where the heater will be operating. If unsure of the elevation, contact the local gas supplier.

METER TIME IN MINUTES AND SECONDS FOR NORMAL INPUT RATING OF FURNACES EQUIPPED FOR NATURAL OR LP GAS											
INPUT BTU/HR	METER SIZE CU. FT.	HEATING VALUE OF GAS BTU PER CU. FT.									
		900		1000		1040		1100		2500	
		MIN.	SEC.	MIN.	SEC.	MIN.	SEC.	MIN.	SEC.	MIN.	SEC.
50,000	ONE TEN	1 10	5 50	1 12	12 00	1 12	15 30	1 13	18 12	3 30	20 00
75,000	ONE TEN	0 7	44 12	0 8	48 0	0 8	50 19	0 8	53 48	2 20	0 0
100,000	ONE TEN	0 5	33 24	0 6	36 0	0 6	38 15	0 6	40 36	1 15	30 0
125,000	ONE TEN	0 4	26 19	0 4	29 48	0 5	30 0	0 5	32 17	1 12	12 0
150,000	ONE TEN	0 3	31 36	0 4	24 0	0 4	25 10	0 4	26 20	1 10	0 0

$$\text{Input BTU/HR} = \frac{\text{Heating Value of Gas (BTU/Ft}^3) \times 3600 \times \text{correction factor}}{\text{Time in Seconds (for 1 cu.ft.) of Gas}}$$

NOTE: THIS ADJUSTMENT CAN ONLY BE DONE AFTER THE HEATER IS IN OPERATION. IT IS INCLUDED IN THE STARTUP PROCEDURES

VALVE OUTLET PRESSURE SETTINGS BY ELEVATION

ALTITUDE Feet	NATURAL GAS (Inches w.c.)	PROPANE GAS (Inches w.c.)
0-2000	3.5	10.0
2001-3000	2.8	7.7
3001-4000	2.5	7.1
4001-5000	2.3	6.4
5001-6000	2.1	5.8
6001-7000	1.9	5.2
7001-8000	1.7	4.6
8001-9000	1.5	4.1

2. With the manual valve positioned to prevent flow to the main burner, connect a manometer to the 1/8" pipe outlet pressure tap in the valve. Use a water column manometer that is readable to the nearest tenth of an inch.
3. Remove the cap from the pressure adjusting screw and adjust the valve outlet pressure to the pressure setting selected from the table. Cycle the main burner once or twice to properly seat the adjustment spring in the valve. Re-check the pressure. If necessary, re-adjust the pressure. When the pressure is correct, remove the manometer and replace the cap. Check for leaks at the pressure tap fitting.
4. With the heater operating determine that the inlet pressure to the heater for natural gas is between 5 and 13.5 inches w.c., and for propane between 10 and 13.5 inches w.c. Take this reading as close as possible to the heater (heaters are equipped with gas valves that have an inlet pressure tap.) If the inlet is not within the specified range, the inlet pressure must be corrected and Steps 3 and 4 repeated.
5. Find the Valve Outlet Pressure Adjustment label in the plastic bag that contained these instructions. Using a permanent marker, fill in the pressure setting. Adhere the label on the heater near the gas valve so that it is conspicuous to someone serving the valve.

Installation Manual for Comfort Pack Gas Non Condensing Furnace

Clearances

Clearance to combustibles is defined as the minimum distance from a heater to a surface or object that is necessary to ensure that a surface temperature of 90°F above the surrounding ambient temperature is not exceeded. Minimum clearance to combustibles from all sides of this properly installed unit is zero inches. Adequate clearances must be provided to allow installation of the union and shutoff valve, as well as accessibility to wiring and control compartments. If this unit is installed in an attic or other insulated space, it must be kept free and clear of insulating material. The area must be inspected when the unit is installed or insulation is added. Some insulating materials may be combustible. (See page 11 for other clearances)

Venting

The venting system is an integral part of the heater as shipped to you. Do not modify or add to the vent system. The heat section includes an exhaust blower. The blower draws the combustion products out of the heat exchanger, mixes combustion products with dilution air and forces the mixture to the outside. A chimney is not required. No special provisions are required for supplying air for combustion. Do not alter or extend the vent outlet. The venting system is designed for proper operation under all weather conditions and for winds up to 40 mph. (See page 11 for locating vent)

Gas Piping and Pressures



WARNING

THIS HEATER IS EQUIPPED FOR A MAXIMUM GAS SUPPLY PRESSURE OF 1/2 POUND, 8 OUNCES OR 14 INCHES WATER COLUMN. SUPPLY PRESSURE HIGHER THAN 1/2 POUND REQUIRES INSTALLATION OF AN ADDITIONAL LOCKUP-TYPE SERVICE REGULATOR EXTERNAL TO THE UNIT.

Gas piping external to the unit must include: a manual shutoff valve with 1/8" NPT plugged tapping (for test gauge connection), drip leg and ground union fitting.

If the supply air from the unit is ducted to space(s) outside the space containing the unit, the return air must be ducted from outside the space containing the unit and sealed to the unit cabinet return air opening.

Pressure Testing Supply Piping

Test Pressures Above 1/2 PSI: Disconnect the heat manual valve from the gas supply line that is to be tested. Cap or plug the supply line.

Test Pressures Below 1/2 PSI: Before testing, close the manual valve on the heater.

All piping must be in accordance with requirements outlined in the National Fuel Gas Code ANSI/Z223,1a (latest edition) or CAN/ CGA-B149.1 and B149.2. Gas supply piping installation should conform with good practice and the local codes. Support gas piping with pipe hangers, metal strapping or other suitable material; do not rely on the heater to support the gas pipe.

CAPACITY OF PIPING												
Cubic Feet Per hour Based on 0.3" w.c. Pressure Drop												
Specific Gravity for Natural Gas - 0.6 (Natural Gas - 1000 BTU/Cubic Feet)												
Specific Gravity for Propane Gas - 1.6 (Propane Gas - 2550 BTU/Cubic Feet)												
LENGTH OF PIPE	DIAMETER OF PIPE											
	1/2"		3/4"		1"		1 1/4"		1 1/2"		2"	
	NATURAL	PROPANE	NATURAL	PROPANE	NATURAL	PROPANE	NATURAL	PROPANE	NATURAL	PROPANE	NATURAL	PROPANE
20'	92	107	190	116	350	214	730	445	1100	671	2100	1281
30'	73	45	152	93	285	174	590	360	890	543	1650	1007
40'	63	38	130	79	245	149	500	305	760	464	1450	885
50'	56	34	115	70	215	131	440	268	670	409	1270	775
60'	50	31	105	64	195	119	400	244	610	372	1105	674
70'	46	28	96	59	180	110	370	226	560	342	1050	641
80'	43	26	90	55	170	104	350	214	530	323	990	604
90'	40	24	84	51	160	98	320	195	490	299	930	567
100'	38	23	79	48	150	92	305	186	460	281	870	531
125'	34	21	72	44	130	79	275	168	410	250	780	476
150'	31	19	64	39	120	73	250	153	380	232	710	433
160'	28	17	59	36	110	67	225	137	350	214	650	397
170'	26	16	55	34	100	61	210	128	320	195	610	372

Note: When sizing lines, consider possibilities of future expansion and increased requirements. Refer to National Fuel Gas Code for additional information on line sizing.

The heater is orificed for operation with natural gas having a heating value of 1000 (+/-50) BTUH per cubic feet or propane gas with a heating value of 2500 (+/-100) BTUH per cubic feet. If the gas at the installation does not meet these specifications, consult the factory for proper orificing. **Pipe joint compounds (pipe dope) shall be resistant to the action of liquefied petroleum gas or any other chemical constituents of the gas being supplied.**

Install a ground joint union and manual shut off valve upstream of the unit control system, as shown in Figure 2. The 1/8" plugged tapping in the shut off valve provides connection for a supply line pressure test gauge**. The National Fuel Gas Code requires the installation of a trap with a minimum 3" drip leg. Local codes may require a minimum drip leg longer than 3" (typically 6"). Gas connection is 1/2". Leak-test all connections by brushing on a leak-detecting solution.



WARNING

ALL COMPONENTS OF A GAS SUPPLY SYSTEM MUST BE LEAK TESTED PRIOR TO PLACING EQUIPMENT IN SERVICE. NEVER TEST FOR LEAKS WITH AN OPEN FLAME. FAILURE TO COMPLY COULD RESULT IN PERSONAL INJURY, PROPERTY DAMAGE OR DEATH.

Valve Outlet Gas Pressure Setting

Measuring valve outlet gas pressure cannot be done until the heater is in operation. Normally adjustments should not be necessary to the factory preset regulator (also, see paragraph on high altitude operation). If adjustment is necessary, the following warnings and instructions apply.



WARNING

VALVE OUTLET GAS PRESSURE MUST NEVER EXCEED 3.5" W.C. FOR NATURAL GAS AND 10" W.C. FOR PROPANE GAS.

Gas Connection and View

Figure 2

Access Panels and Heat Exchanger Inspection Panel

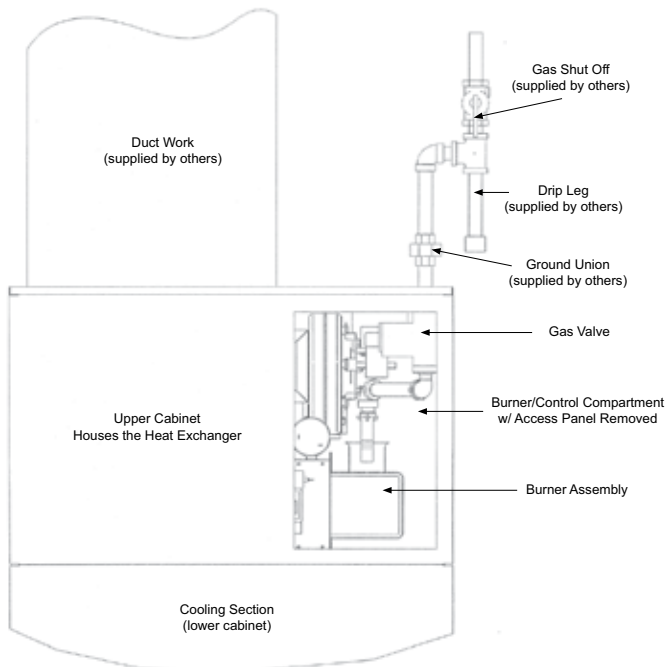

*Install the heat exchanger inspection panel in the ductwork in such a manner that will prevent air leaks.

**1/8" NPT plugged tapping for test gauge not permitted in the Massachusetts.

For Natural Gas: When the heater leaves the factory, the combination gas valve is set so that the valve outlet gas pressure is regulated to 3.5" w.c. Inlet supply pressure to the valve for natural gas must be a minimum of 5" w.c. and a maximum of 14" w.c. Normally, field adjustment should not be required.

For Propane Gas: When the heater leaves the factory, the combination gas valve is set so that the valve outlet gas pressure is regulated to 10" w.c. Inlet supply pressure to the valve for propane gas must be a minimum of 11" w.c. and a maximum of 14" w.c. Normally, field adjustment should not be required.

Before attempting to measure or adjust valve outlet gas pressure, the inlet supply pressure **must** be within the specified range both when the heater is in operation and on standby.

Incorrect inlet pressure could cause excessive valve outlet gas pressure immediately or at some future time. If natural gas supply pressure is too high, install a regulator in the supply line before it reaches the heater. If natural gas supply pressure is too low, contract your gas supplier.

Instructions on How to Check Valve Outlet Pressure

(Can only be done after heater is installed):

1. With the manual valve positioned to prevent flow to the main burner, connect a manometer to the 1/8" pipe outlet pressure tap in the valve. NOTE: A manometer (fluid-field gauge) is recommended rather than a spring type gauge due to the difficulty of maintaining calibration of a spring type gauge.
2. Open the valve and operate the heater. Measure the gas pressure at the outlet of the automatic gas valve. Normally adjustments should not be necessary to the factory-preset regulator. If adjustment is necessary, set pressure to correct settings

by turning the regulator screw IN (clockwise) to increase pressure. Turn regulator screws OUT (counterclockwise) to decrease pressure. (See Figure 4 on Page 24)



CAUTION

ROUTE THE WIRES SO THAT THEY DO NOT CONTACT THE FLUE GAS COLLECTION BOX OR VENTER HOUSING. CONSULT THE WIRING DIAGRAM SUPPLIED WITH YOUR HEATER.

IF ANY OF THE ORIGINAL WIRES AS SUPPLIED WITH THE APPLIANCE MUST BE REPLACED, IT MUST BE REPLACED WITH WIRING MATERIAL HAVING A TEMPERATURE RATING OF AT LEAST 105°C, EXCEPT FOR LIMIT CONTROL, FLAME ROLLOUT SWITCH AND SENSOR LEAD WIRES, WHICH MUST BE 150°C. PLEASE SEE “HAZARD INTENSITY LEVELS”.

Ignition System

This heater is equipped with a direct spark integrated control system. The system monitors the safety devices and controls the operation of the blower and venter motors and the gas valve between heat cycles. It also controls the blower for cooling.

Ignition System Operating Sequence

– On a call for heat from the thermostat, the system energizes the venter motor and goes through a 30-second prepurge. The system verifies that the pressure switch, the high limit and the flame rollout switch are in the closed state. The gas valve is then energized and the ignition system provides the high voltage spark to the electrode to ignite the main burner gas. Burner flame is electronically sensed by the control upon carry over of flame. (A separate solid metal probe is used as the flame sensing function. A low voltage electrical signal is imposed on the metal probe that is electrically isolated from ground. When the flame impinges on the flame sensing probe, the flame acts as a conduction path to ground. The flame rectifies and completes the DC circuit and the ignition system acknowledges the flame.) The fan motor is energized by the system after 20 seconds of flame sensing. After the thermostat has been satisfied, the system de-energizes the gas valve, the venter motor goes through a 30-second post-purge and the fan motor remains energized for an additional time.

NOTE: This is a three trial system. Should the unit not sense burner flame, two additional tries will be made. If the unit does not sense flame in three tries, it will lockout for one hour before initiating another 3-sequence trial for ignition. To initiate another trial for ignition before the one hour elapses requires that either the thermostat be reset or the power to the unit be interrupted for 30 seconds. The user should not continue to try resetting the system. Contact a qualified service agency.

Combustion Air Proving Switch

The combustion air proving switch is a pressure sensitive switch that monitors air pressure to ensure that proper combustion air flow is available. The switch is a single pole/normally open device that closes when a decreasing pressure is sensed in the venter housing.

On start-up when the heater is cold, the sensing pressure is at the most negative level, and as the heater warms up, the sensing pressure becomes less negative. After the system has reached equilibrium (about 10 minutes), the sensing pressure levels off.

If a restriction causes the sensing pressure to be outside the switch setpoint, the pressure switch will function to shut off the main burner. The main burner will remain off until the system has cooled and/or the resistance is reduced. The Table below lists the approximate water column negative pressure readings and switch setpoints for sea level operating conditions.

START-UP COLD	1.0 +/- .1
EQUILIBRIUM	.72 +/- .05
SETPOINT “OFF”	.55
SETPOINT “ON”	.65

Limit Switch

All units are equipped with a temperature activated auto reset limit control. The control is factory set and is non-adjustable. If the setpoint is reached, the limit control acts to interrupt the electric supply to the gas valve. This safety device provides protection in the case of motor failure or lack of airflow due to a restriction at the inlet or outlet.

Flame Rollout Switch

All units are equipped with a temperature activated manually reset switch. The flame rollout switch is located centrally on the top of the burner assembly. It is factory set and is non-adjustable. If the setpoint is reached, the flame rollout acts to interrupt the electric supply to the gas valve. If the flame rollout switch activates, identify and correct the cause before resetting the switch. Refer to the Maintenance Section for information on probable causes and instructions on resetting the flame rollout switch.

Burner

The heater has a one-piece burner designed to provide controlled flame stability without lifting or flashback with either natural or propane gas. The burner can be removed as a unit for inspection or service the flame rollout acts to interrupt the electric.

Gas Valve

The heater has a one-piece burner designed to provide controlled flame stability without lifting or flashback with either natural or propane gas. The burner can be removed as a unit for inspection or service. the flame rollout acts



WARNING

THE OPERATING VALVE IS THE PRIME SAFETY SHUTOFF. ALL GAS SUPPLY LINES MUST BE FREE OF DIRT OR SCALE BEFORE CONNECTING THE UNIT TO ENSURE POSITIVE CLOSURE. SEE HAZARD INTENSITY LEVELS, PAGE 5.

Start Up

Check Installation - Check the installation prior to start-up:

1. Unit must be secure and level.
2. Verify proper clearances from combustibles.
3. Check vent and combustion air systems to be sure that they are not blocked.
4. Check piping for leaks and proper gas line pressure. Bleed gas lines of trapped air.
5. Check electrical wiring. Be sure all wire gauges are as recommended. A service disconnect switch should be used. Verify that fusing or circuit breakers are adequate for the load use.

6. Verify that the return air duct connection is physically sound, sealed to the unit cabinet and terminates outside of the space containing the furnace.
7. Check that the vent connector is in place and is physically sound without holes or excessive corrosion.
8. Check that flue product carrying areas external to the furnace are clear and free of obstructions.
9. Check that there are no obvious signs of deterioration of the furnace.
10. Check that the physical support of the unit and furnace are sound without sagging, cracks, gaps, etc., around the base so as to provide a seal between the support and the base

These examinations should be done by qualified service personnel prior to initial start-up, and then at least on a yearly basis.

Heater Start-Up

SAFETY WARNINGS

WARNINGS: FOR YOUR SAFETY, READ BEFORE OPERATING. IF YOU DO NOT FOLLOW THESE INSTRUCTIONS EXACTLY, A FIRE OR EXPLOSION MAY RESULT CAUSING PROPERTY DAMAGE, PERSONAL INJURY OR LOSS OF LIFE.

- This appliance does not have a pilot. It is equipped with an ignition device that automatically lights the burner. Do not try to light the burner by hand.
- Before operating, smell all around the appliance area for gas. Be sure to smell next to the floor because some gas is heavier than air and will settle on the floor.

WHAT TO DO IF YOU SMELL GAS?

(See next page)

WHAT TO DO IF YOU SMELL GAS.

- Do not try to light any appliance.
- Do not touch any electrical switch; do not use any phone in your building.
- Immediately call your gas supplier from a neighbor's phone. Follow the gas supplier's instructions..
- If you cannot reach your gas supplier, call the fire department
- Do not touch any electrical switch; do not use any phone in your building.
- Use only your hand to turn the gas control ON/OFF knob on the gas valve. Never use tools. If the valve ON/OFF knob will not turn by hand, do not try to repair it. Call a qualified service technician. Force or attempted repair may result in a fire or explosion.
- Should overheating occur, or the gas supply fail to shut off, turn off the manual gas valve to the appliance before shutting of the electrical supply.
- Do not use this appliance if any part has been under water. Immediately call a qualified service technician to inspect the appliance and to replace any part of the control system and any gas control that has been under water

Operating Instructions and Operating Sequence

1. Set thermostat at lowest setting.
2. Turn off all electric power to the appliance.
3. This appliance is equipped with an ignition device that automatically lights the burner. Do not try to light the burner by hand. Open the access door and locate the gas control (ON/OFF) knob on the gas valve.
4. Turn the gas control knob clockwise to "OFF."
5. Wait five (5) minutes to clear for any gas. Then smell for gas, including near the floor. If you smell gas, STOP! and follow the steps in the WARNINGS above or on the Operating Label on the heater. If you do not smell gas, proceed to the next step.
6. Turn the gas control knob counterclockwise to "ON." Close the access door.

7. Turn on the electric power to the heater.
8. Set the thermostat to the desired setting.
 - Thermostat calls for heat, energizes venter motor.
 - Venter pressure switch closes, firing the unit.
 - Burner flame is sensed and in 30 seconds, the fan motor is energized.
 - If the flame is extinguished during the main burner operation, the integrated control system closed the main valve and must be reset by interrupting power to the control circuit (see lighting instructions on the heater).

NOTE: IF THE APPLIANCE DOES NOT OPERATE, FOLLOW THE INSTRUCTIONS "TO TURN OFF GAS TO APPLIANCE" (BELOW) AND CALL YOUR SERVICE TECHNICIAN.

To Turn Off Gas To The Appliance

1. Set thermostat to lowest setting.
2. If service is to be performed, turn off all electrical power to the appliance.
3. Open the access door.
4. Turn the gas control knob clockwise to "OFF."
Do not force.
5. Close the access door.

Check Installation After Start-Up

- If the heater is being derated for high altitude operation, follow the instructions to adjust the valve outlet pressure. Be sure to complete the "change pressure" tag and adhere it to the heater close to the gas valve.
- If unit is not being derated, measure to verify valve outlet gas pressure.
- Inspect the venting system. Determine that there is no blockage or restriction or leakage.
- Turn the unit off and on, pausing two minutes between each cycle. Observe for smooth ignition.

Special Notes for Extremely Cold Weather Areas (below - 20°F/-29°C

In areas where extremely cold outdoor temperatures can be expected, some additional installation and operating precautions

Installation Manual for Comfort Pack Gas Non Condensing Furnace

should be taken to prevent possible vent system ice blockage that could result in safety shutdown of the burners:

1. Adjust to the highest achievable temperature rise within the rise and static pressure ranges specified on the rating plate.
2. Make sure there are no leaks of outside air into the return air system.
3. Keep the outside louver grill as free as possible of any ice that may form and obstruct the flue outlet.



DANGER

THE GAS BURNER IN THIS GAS-FIRED EQUIPMENT IS DESIGNED AND EQUIPPED TO PROVIDE SAFE AND COMPLETE COMBUSTION. HOWEVER, IF THE INSTALLATION DOES NOT PERMIT THE BURNER TO RECEIVE THE PROPER SUPPLY OF COMBUSTION AIR, COMPLETE COMBUSTION MAY NOT OCCUR. THE RESULT IS INCOMPLETE COMBUSTION THAT PRODUCES CARBON MONOXIDE, A POISONOUS GAS THAT CAN CAUSE DEATH. SAFE OPERATION OF DIRECT-FIRED GAS BURNING EQUIPMENT REQUIRES A PROPERLY OPERATING VENT SYSTEM THAT VENTS ALL FLUE PRODUCTS TO THE OUTSIDE ATMOSPHERE. FAILURE TO PROVIDE VENTING WILL RESULT IN A HEALTH HAZARD WHICH COULD CAUSE SERIOUS PERSONAL INJURY OR DEATH. ALWAYS COMPLY WITH THE COMBUSTION AIR REQUIREMENTS IN THE INSTALLATION CODES. COMBUSTION AIR AT THE BURNER SHOULD BE REGULATED ONLY BY MANUFACTURER-PROVIDED EQUIPMENT. NEVER RESTRICT OR OTHERWISE ALTER THE SUPPLY OF COMBUSTION AIR TO ANY HEATER.

Figure 4: Gas Control

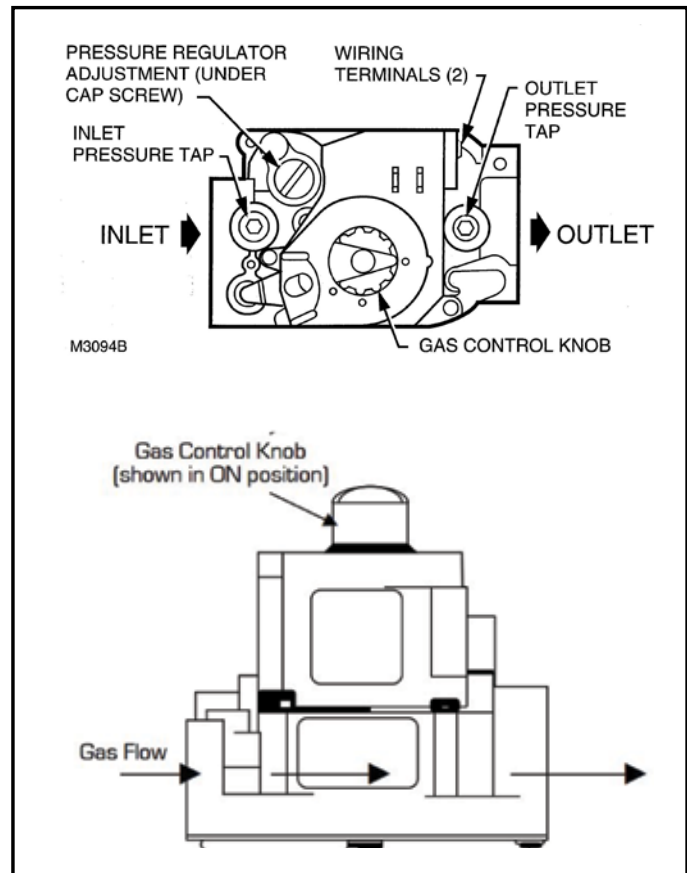

Maintenance and Service

The 16" x 25" x 1" filter on the cooling chassis must be maintained regularly to assure that the unit provides optimal performance and energy efficiency. The intervals between replacing depends entirely on the cleanliness of the return air to the unit and the time that the indoor blower operates. The air filter is accessible by removing the lower access panel. The filter should be inspected and replaced as needed and is not washable. Substituting the air filter with media other than the type provided with the unit is not recommended, since other materials may cause additional static pressure, which could reduce the air delivery of the unit. **The unit should never be operated without the air filter and access panels in place.**

Cooling Chassis

The cooling chassis contains all items related to the cooling functions of the unit, and also contains the indoor blower and motor for the heating function. For extensive servicing, qualified personnel may choose to remove the cooling chassis from the unit and take it to a work area. Spare chassis are recommended so that extensive servicing can be performed outside the living space. This will prevent introducing dirt or doing damage in the living area, and could help to eliminate significant disruption of the air conditioning and heating functions in the living areas.

The indoor blower motor and the outdoor fan motor have permanently lubricated bearings and do not require routine service. The refrigeration system is sealed and factory charged with R-410A so that routine maintenance is not required. The electrical controls do not require routine service. Cleaning of the outdoor coil, indoor coil,

Installation Manual for Comfort Pack Gas Non Condensing Furnace

drain pan, and inside the bottom of the chassis are recommended at least once a year, and more often if the equipment is operated in a dusty or hostile environment. The outdoor coil is an aluminum microchannel condensing coil with an anti-corrosion coating that requires specific precaution when cleaning. It is recommended to rinse the coil using a low pressure hose (less than 70 psi) to prevent buildup of dirt and debris. Rinse from the outside of the coil in, making sure to protect the condenser motor from water damage during the cleaning process. Leaves, twigs, and other large debris should be removed with a soft, non-metallic bristle brush prior to rinsing of the coil to prevent debris from being forced between the fins. Care should be taken not to use the brush horizontally across the fins as they are easily damaged.

DO NOT USE CHEMICALS, HOUSEHOLD BLEACH, OR ACID CLEANERS AS THEY WILL ACCELERATE CORROSION ON THE COIL. AVOID USING PRESSURE WASHERS, HIGH PRESSURE HOSES, OR HIGHLY COMPRESSED AIR TO CLEAN THE COIL. DOING SO CAN PERMANENTLY DAMAGE THE COIL, REDUCE UNIT PERFORMANCE, AND VOID THE WARRANTY.

Power to the unit should always be turned off before performing service or removing the cooling chassis from the unit. One power connector and one control circuit connector are provided for easy disconnecting and re-connecting of the wires between the cooling chassis and cabinet. The controls enclosure cover must be removed to allow access to the screws holding the indoor blower cover plate to the cooling chassis and cabinet. **After reinstalling the cooling chassis, the indoor blower cover plate and controls enclosure cover must be reinstalled.**



WARNING

IF YOU TURN OFF POWER SUPPLY, TURN OFF THE GAS. SEE HAZARD LEVELS, PAGE 3. THE MATERIAL CONTAINED IN THE MAINTENANCE AND SERVICE SECTION OF THIS MANUAL IS DESIGNED TO AID A QUALIFIED SERVICE PERSON IN MAINTAINING AND SERVICING THIS EQUIPMENT. THIS UNIT WILL OPERATE WITH MINIMUM MAINTENANCE. TO ENSURE LONG LIFE AND SATISFACTORY PERFORMANCE, A HEATER THAT IS OPERATED UNDER NORMAL CONDITIONS SHOULD BE INSPECTED AND CLEANED AT THE START OF EACH HEATING SEASON. IF THE HEATER IS OPERATING IN AN AREA WHERE AN UNUSUAL AMOUNT OF DUST, SOOT OR OTHER IMPURITIES ARE PRESENT IN THE AIR, MORE FREQUENT MAINTENANCE IS RECOMMENDED. WHEN ANY SERVICE IS COMPLETE, BE CAREFUL TO REASSEMBLE CORRECTLY TO ENSURE THAT NO UNSAFE CONDITIONS ARE CREATED. WHEN RE-LIGHTING, ALWAYS FOLLOW THE LIGHTING INSTRUCTIONS ON THE HEATER.

Maintenance Schedule

At least every six weeks check the filter. Clean or replace as necessary. A clean filter in addition to providing a comfortable environment ensures fuel-efficient operation and long heat exchanger life. Do the following procedures at least annually.

- Clean all dirt, lint, and grease from the combustion air openings and venter motor.
- Inspect the heat exchanger. Clean if needed.
- Check the burner for scale, dust, or lint accumulation. Clean if needed.
- Check the vent system for soundness. Replace any parts that do not appear sound.
- Check the wiring for any damaged wire. Replace damaged wiring.

NOTE: USE ONLY FACTORY-AUTHORIZED REPLACEMENT PARTS.

Burner/Control Compartment

Heat Section Burner/Control Compartment

Showing Locations of Burner Assembly and Controls

NOTE: Unit side panel is removed for clarity; side panel is not removable. Access to the burner/control compartment is through the small rear access panel as illustrated below.

Figure 5

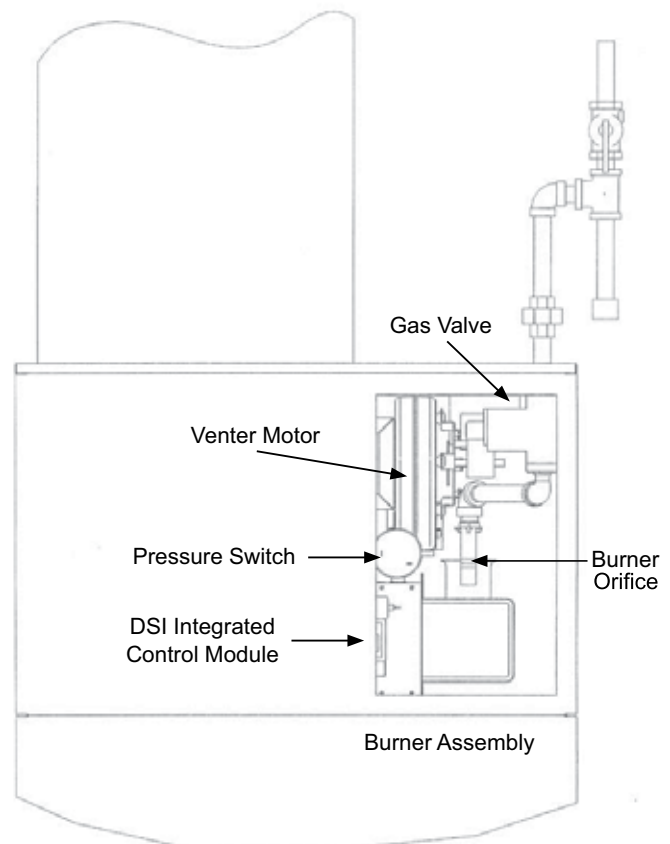

Inspect the Heat Exchanger

Remove the heat furnace baffle panel (see page 29). Remove any dirt or dust accumulation. Visually check the heat exchanger for cracks and holes. If a crack or hole is observed, replace the heat exchanger. Thorough inspection of the heat exchanger can be done with furnace slid out of the cabinet. (See pages 29 & 30)

Burner Service

Inspect the burner/control compartment annually to determine if cleaning is necessary. Open the burner/control compartment and on the burner housing, clean the compartment and follow the instructions below to remove and clean the burner.

Instructions for Burner Removal

Note: Components may be more easily accessed with the furnace removed from cabinet. (See page 29 & 30)

1. Shut the gas supply off ahead of the combustion valve.
2. Turn off electric supply.
3. Remove the upper cabinet panel to expose the heat exchanger section and the burner/control compartment (see Figure 2).
4. Carefully loosen and remove the gas valve and gas train from the side panel and burner orifice bracket.
5. Mark and disconnect the pressure switch wires. Disconnect the tubing and remove the pressure switch.
6. Locate the secondary air shield end cap. Remove the four screws holding it to the air shield and remove the end cap.
7. Locate the upper burner brackets (one on each side). Remove the two screws (one on each side) that attach the burner assembly to the secondary air shield assembly.
8. Tilt the burner assembly slightly and lift it free from the retaining track under the burner assembly. Remove the burner assembly from the cabinet.

Figure 6A

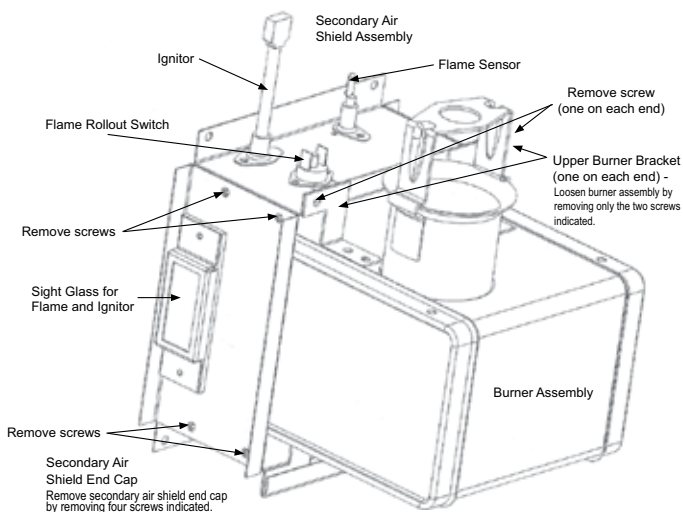

Inspect and Clean the Burner

With the burner assembly removed, shine a flashlight on the burner ribbons. Look for carbon buildup, scale, dust, lint, and/or anything that might restrict flow through the spaces between the burner ribbons. Holding the burner assembly so that any foreign material will fall away from the burner, use a stiff bristle brush to loosen and remove any foreign material(s). If the burner is excessively dirty, refer to Figure 6A and remove one of the burner end caps. Remove the four screws that hold the end cap to the burner housing. Lightly tap the end cap to remove it.

Clean all foreign material from the burner and venturi. After the burner is thoroughly clean, replace the end cap making certain that it is tight against the burner housing.

NOTE: IF ANY OF THE BURNER COMPONENTS ARE DAMAGED OR DETERIORATED, REPLACE THE BURNER ASSEMBLY.

Inspect the Lower Portion of the Heat Exchanger (with burner assembly removed)

At the burner flame entrance of each tube, shine a bright light into each heat exchanger section. If any light is observed, replace the heat exchanger.

Instructions for Burner Installation

1. With lower burner brackets going inside the retaining track, set the fully assembled, clean burner in the unit.
2. Secure the upper burner brackets to the secondary air shield assembly.
3. Replace the secondary air shield end cap.
4. Attach and reconnect the pressure switch.
5. Reinstall the gas train and gas valve to the burner orifice bracket and side panel.
6. Turn on the electric and the gas. Operate the furnace. Check gas supply lines with a liquid leak detector or soap solution. After it has been determined that there are no gas leaks and the burner is operating satisfactorily, replace the cabinet panel and the burner/control compartment panel.

Figure 6B

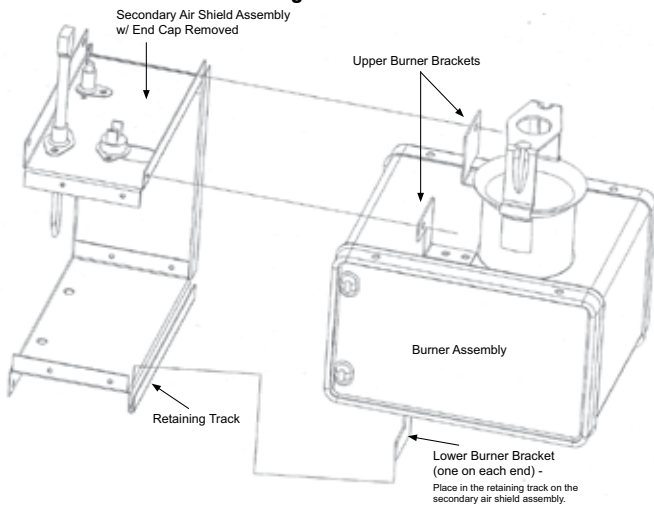

Burner Orifice

Burner orifice only needs to be replaced when a change in gas is made. When ordering a replacement orifice, give BTUH content and specific gravity of gas, as well as the model and serial number of the unit. To prevent dropping the orifice into the burner housing, block the venturi with something the size of a credit card when removing the burner orifice. Be careful not to damage the venturi tube and/or the bracket.

Ignition System

Igniter - Refer to Figure 6A and locate the igniter. Disconnect the wire; remove the screw and the igniter. Clean the igniter assembly with an emery cloth. Spark gap must be maintained to 1/8" (See Figure 7) below.

Flame Sensor - Refer to Figure 6A and locate the flame sensor. Disconnect the wire; remove the screw and the flame sensor. Clean with an emery cloth.

Figure 7

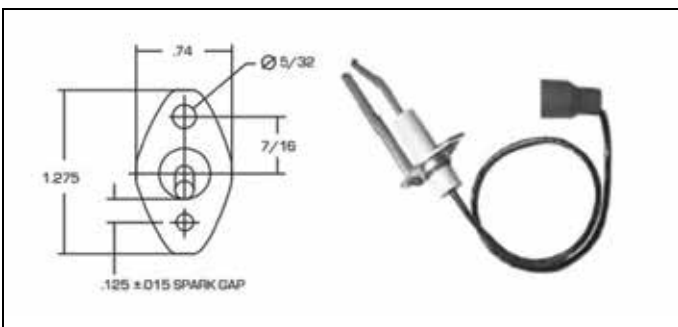

CAUTION

DUE TO HIGH VOLTAGE ON THE SPARK WIRE AND ELECTRODE, DO NOT TOUCH WHEN ENERGIZED. SEE HAZARD LEVELS, PAGE 5.

DSI Integrated Control Module - The module monitors the operation of the heater including ignition. The only replaceable component is the 3 amp fuse. If the fuse is blown, the problem is most likely an external overload. Correct the problem and replace the fuse. Do not attempt to disassemble the control module. However, each heating season check the lead wires for insulation deterioration and good connections.

Proper operation of the direct spark ignition system requires a minimum flame signal of 1.0 microamps as measured by a microammeter.

For further information and check out procedure on the direct spark ignition system, refer to the circuit board manufacturer's instructions supplied with the heater.

Venter Motor and Wheel Assembly

Remove dirt and grease from the motor casing. Venter motor bearings are permanently lubricated. The DSI Integrated Control Module controls and monitors operation of the venter motor. If the contacts fail to close the venter motor will not run. If the contacts fail to open, the venter motor will not shut off, preventing the combustion air pressure switch from opening.

Follow these instructions for replacement of the venter motor and wheel assembly. Keep all hardware removed to be used in reassembling and installing the replacement parts.

1. Turn off the gas and disconnect the electric power.
2. Open the burner/control compartment access panel.
3. Disconnect the three venter motor wires at their terminal block connections.
4. Holding the motor, remove the three screws that attach the venter motor mounting plate to the venter housing. Remove the motor and wheel assembly from the heater.
5. Re-assemble with the replacement venter motor and wheel assembly.
6. Follow the wiring diagram to connect the venter wires.
7. Restore power to the heater and turn on the gas. Light, following the instructions plate. Check for proper operation. Replace the access panel.

Limit Control

If it is determined that a limit control needs replacing, use only the factory-authorized replacement part that is designed for the size of heater. The limit control is accessible in the control compartment. For approximate limit control location (see Figure 1).

Gas Valve

The gas valve requires no field maintenance except careful removal of external dirt accumulation and checking of wiring connections. Instructions for testing pressure settings are in paragraph entitled "Gas Piping and Pressures."



CAUTION

THE OPERATING VALVE IS THE PRIMARY SAFETY SHUTOFF. ALL GAS SUPPLY LINES MUST BE FREE OF DIRT OR SCALE BEFORE CONNECTING TO THE UNIT TO ENSURE POSITIVE CLOSURES. SEE HAZARD INTENSITY LEVELS, PAGE 3.

Pressure Switch

If it is determined that the pressure switch needs replacing, use only the factory-authorized replacement part that is designed for this heater. For approximate location (see Figure 5).

NOTE: A unit operating above 6000 ft elevation requires a high altitude pressure switch, P/N 14208325 (see page 17).

Flame Rollout Switch

For approximate location (see Figure 6A). The cause of a flame rollout switch activating must be determined. Activation of the manually reset flame rollout switch could be caused by one or more of the following: • Restricted or plugged heat exchanger. • Pressurization of the heat exchanger. • Restricted combustion air inlet or exhaust outlet in combination with a defective pressure switch. • Electrical power interruption during operation. If a flame rollout switch trips, inspect the burner/control compartment for signs of excessive heat and burned wiring.

If the compartment appears normal, reset by depressing the red button on the switch. 15 to 20 minutes are required for the switch to cool sufficiently for resetting. A distinct click will be felt when the switch resets. Operate the furnace. If the flame rollout switch trips again, determine and correct the cause before resetting the switch.

If there is damage to the burner/control compartment, repairs must be made before resetting the switch.

If it is determined that the flame rollout switch needs replacing, use only the factory-authorized replacement part that is designed for that size of heater.

Vent System

Check at least once a year. Inspect all joints and seams. Replace any defective parts.

Troubleshooting

Check the DSI Integrated Control Module (Circuit Board) - The Integrated Circuit Board monitors the operation of the heater and includes an LED signal that indicates normal operation and various abnormal conditions. If the heater fails to operate properly, check this signal to determine the cause and/or to eliminate certain causes.

Do not attempt to repair the DSI integrated control module; the only field replaceable component is the fuse.

CONTROL STATUS	GREEN LED
STEADY ON	Normal operation, no call for heat
FAST FLASH	Normal operation, call for heat
1 FLASH	In lockout from failed ignition or flame loss
2 FLASH	Pressure switch does not close for 240 seconds
3 FLASH	Limit switch or rollout switch open
4 FLASH	Limit switch is closed before venter is energized
STEADY OFF	Internal control fault or no power
FLAME STATUS	YELLOW LED
STEADY ON	Flame sensed
SLOW FLASH	Weak flame (current below 1.0 microamps = +/-50%)
FAST FLASH	Undesired flame (valve open and no call for heat)

Installation Manual for Comfort Pack Gas Non Condensing Furnace

Directions to Slide Out the Furnace (After removing front panels)

1. Remove the (4) screws indicated at the right

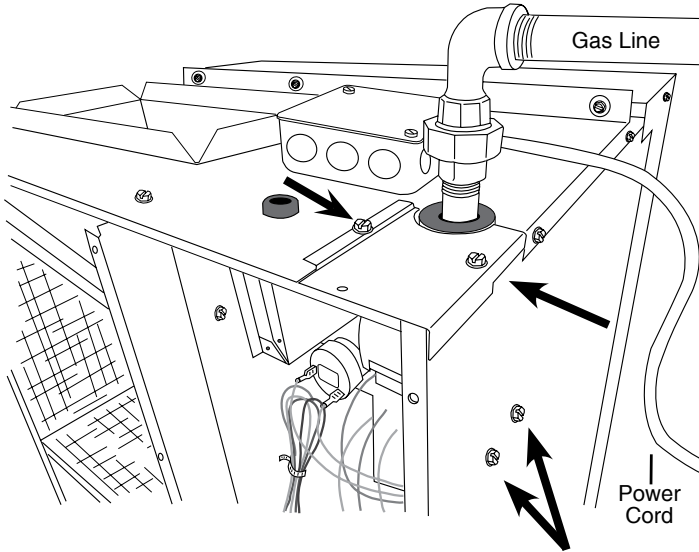

3. Remove (2) right side screws and remove the front furnace baffle.

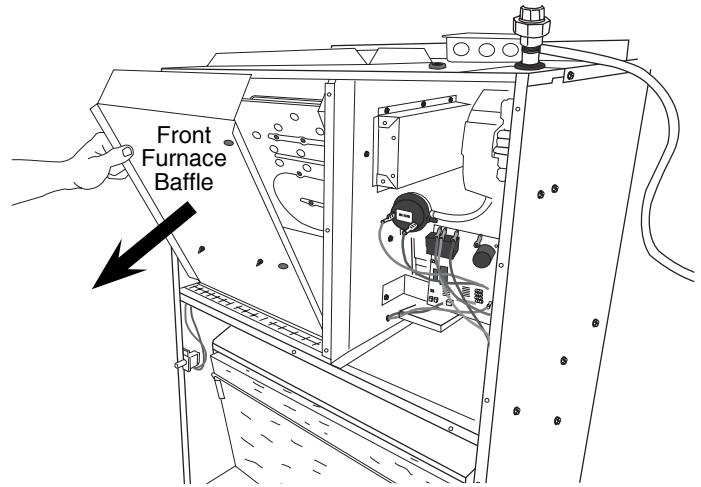

2. Remove the patch plate

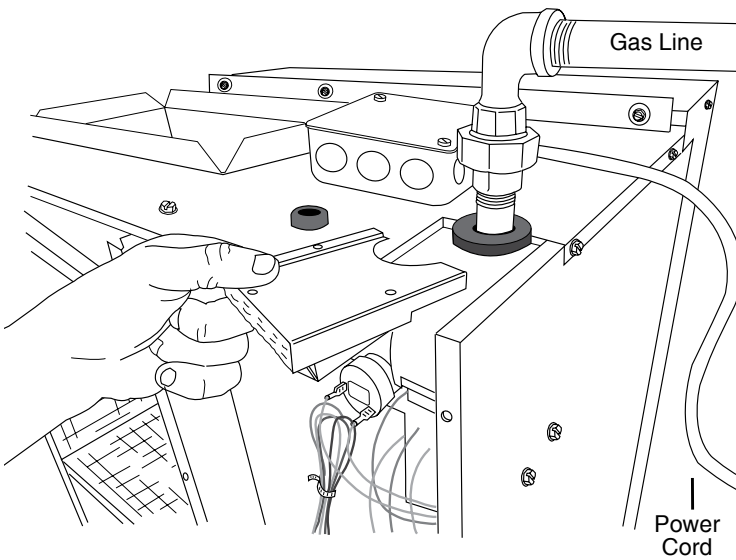

Installation Manual for Comfort Pack Gas Non Condensing Furnace

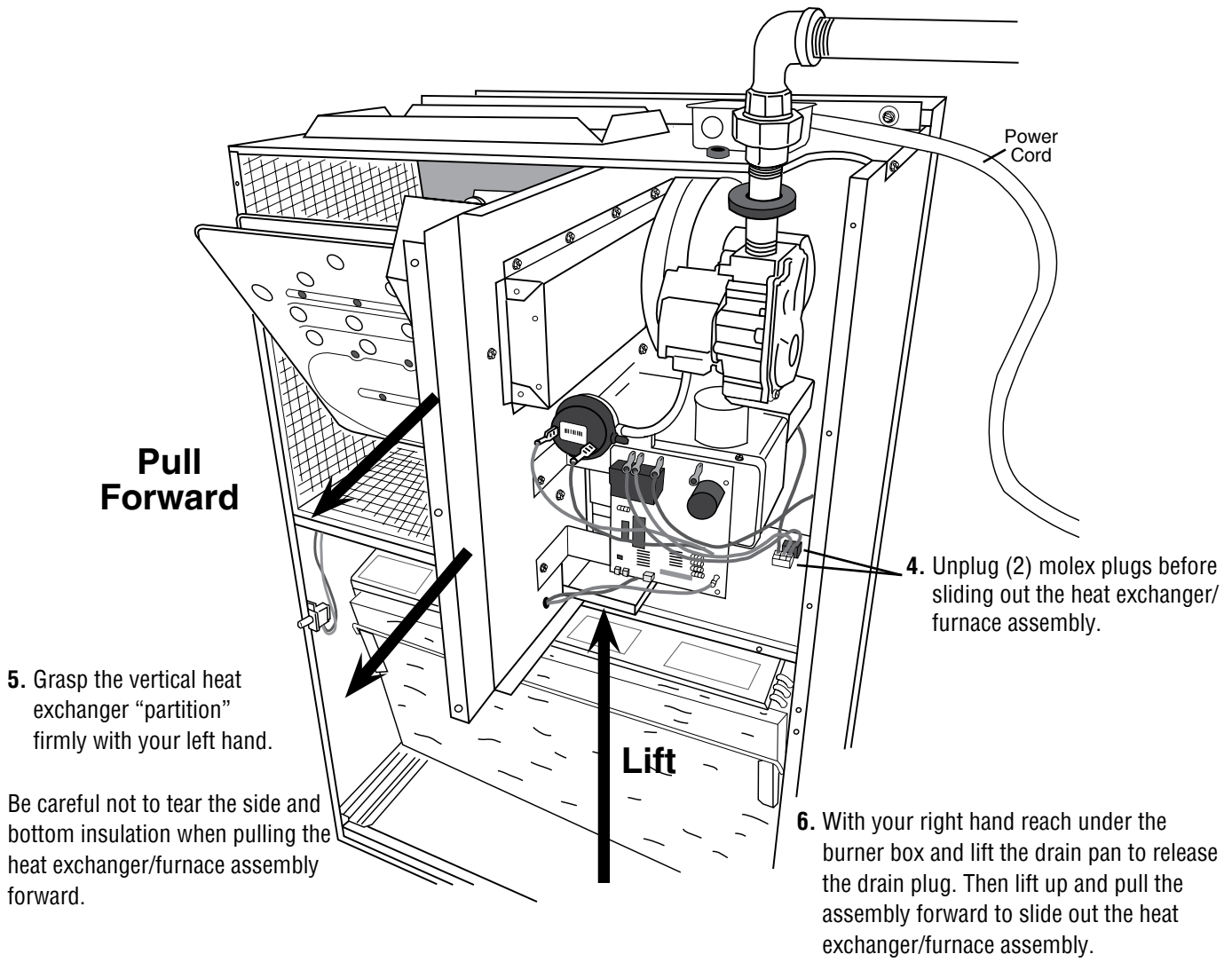

Installation Manual for Comfort Pack Gas Non Condensing Furnace

Performance Data | 12 SEER – 80% AFUE

Models	Nominal Cooling Tons	Cooling BTU	Heating BTU Input	Heating BTU Output
CPG41128-U	1	12,000	28,000	22,400
CPG41138-U	1	12,000	38,000	30,400
CPG41728-U	1.5	17,500	28,000	22,400
CPG41738-U	1.5	17,500	38,000	30,400
CPG41751-U	1.5	17,500	51,000	40,800
CPG41764-U	1.5	17,500	64,000	51,200
CPG42328-U	2	22,000	28,000	22,400
CPG42338-U	2	22,000	38,000	30,400
CPG42351-U	2	22,000	51,000	40,800
CPG42364-U	2	22,000	64,000	51,200

Electrical Data

Models	Voltage	Compressor		Outdoor Fan Motor			Indoor Blower Motor		Total Amps	Minimum Circuit Amps	Maximum Overcurrent Protector
		RLA	LRA	HP	FLA	LRA	HP	FLA			
CPG41128-U	208-230/60/1	4.7	29.5	1/4	2.4	–	1/3	3.0	10.1	11.3	15
CPG41138-U	208-230/60/1	4.7	29.5	1/4	2.4	–	1/3	3.0	10.1	11.3	15
CPG41728-U	208-230/60/1	6.5	37.5	1/4	1.8	3.6	1/3	3.0	11.3	13	15
CPG41738-U	208-230/60/1	6.5	37.5	1/4	1.8	3.6	1/3	3.0	11.3	13	15
CPG41751-U	208-230/60/1	6.5	37.5	1/4	1.8	3.6	1/3	3.0	11.3	13	15
CPG41764-U	208-230/60/1	6.5	37.5	1/4	1.8	3.6	1/3	3.0	11.3	13	15
CPG42328-U	208-230/60/1	8.4	37	1/4	2.4	–	1/2	3.9	14.7	16.8	25
CPG42338-U	208-230/60/1	8.4	37	1/4	2.4	–	1/2	3.9	14.7	16.8	25
CPG42351-U	208-230/60/1	8.4	37	1/4	2.4	–	1/2	3.9	14.7	16.8	25
CPG42364-U	208-230/60/1	8.4	37	1/4	2.4	–	1/2	3.9	14.7	16.8	25

Part No.

Description

CPWS	Comfort Pack Wall Sleeve
CPSG-P	Comfort Pack Stamped Grille Painted
CPLG	Comfort Pack Architectural Louver Grille
CPLG-S	Comfort Pack Architectural Louver Grille for Sleeve (Attaches to Wall Sleeve Only)
CPLG-P	Comfort Pack Architectural Louver Grille Painted (Attaches to Units Only)
CPLG-SP	Comfort Pack Architectural Louver Grille Sleeve Painted (Attaches to Wall Sleeve Only)
A	Omit Stamped Grilles
B	Slotted Filter Door
C	Combination of both A & B
14208343	LP Kit (38 MBTU)
14208344	LP Kit (51 MBTU)
14208345	LP Kit (64 MBTU)

NOTE: National Comfort Products offers Architectural Louver Grilles for all models. Outdoor grilles provided by others must be approved by National Comfort Products to maintain unit performance and warranty coverage. See *Architectural Options Specification Sheet* for more details.

Check Your Temperature Rise

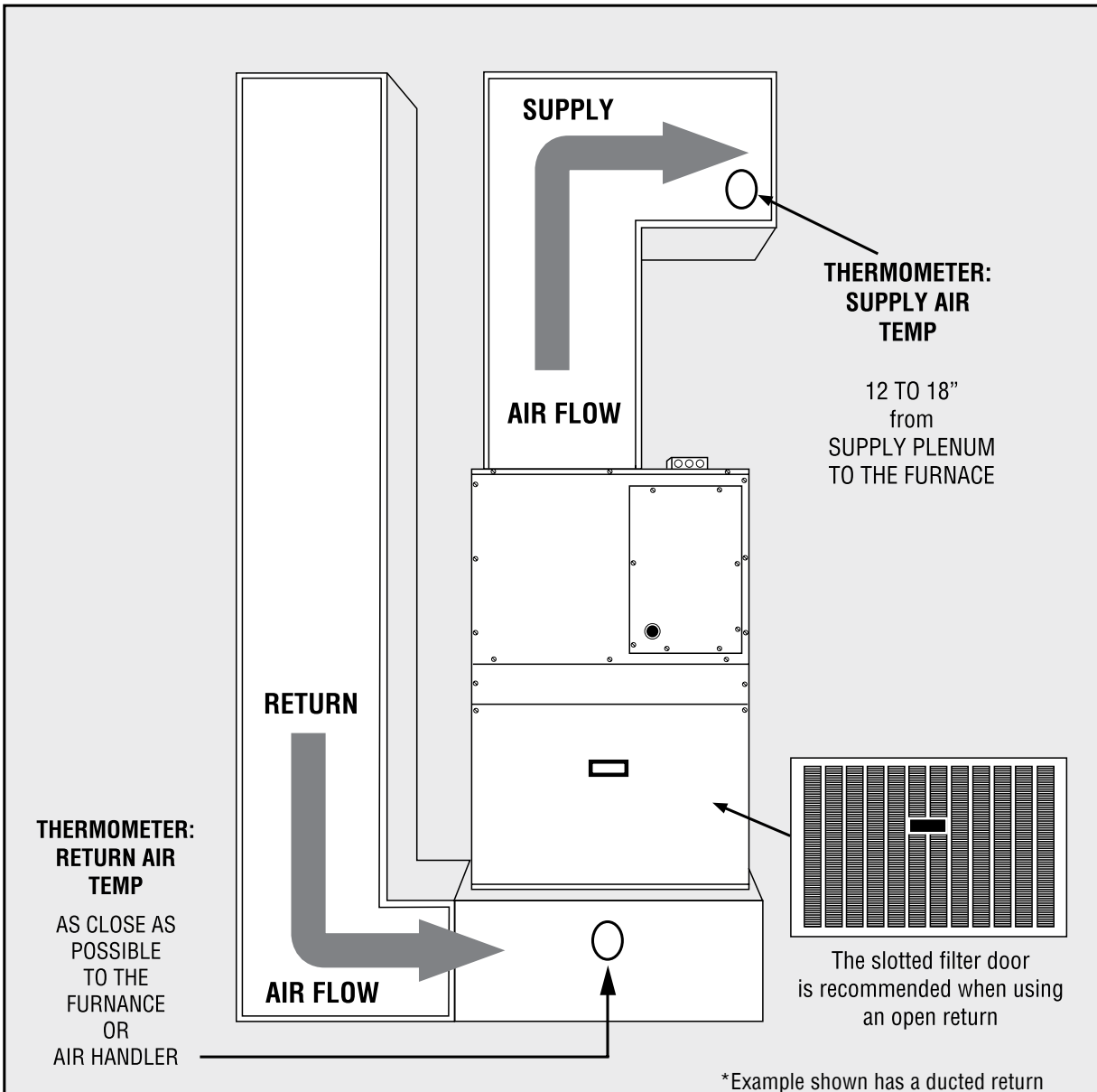

The temperature rise should be as follows

28MBTU = 52.5°F Nominal (45°F to 60°F)

38MBTU = 52.5°F Nominal (45°F to 60°F)

51MBTU = 55°F Nominal (45°F to 65°F)

64MBTU = 67°F Nominal (60°F to 80°F)

In order to calculate CFM use the formula

$CFM = BTU \text{ Output} / (1.08 \times \text{Temp. Rise})$

See page 35 for airflow data.

Installation Manual for Comfort Pack Gas Non Condensing Furnace

Comfort Pack Gas CFM and Temperature Rise 28,000 BTU Input												
UNIT SIZE	COLOR	SPEED	.1" w.c.	TD	.2" w.c.	TD	.3" w.c.	TD	.4" w.c.	TD	.5" w.c.	TD
CPG41128	Red	1	780	26.6	770	26.9	760	27.3	725	28.6	680	30.5
	Yellow	2	715	29.0	690	30.1	660	31.4	620	33.5	560	37.5
	Blue	3	620	33.5	580	35.8	520	39.9	450	46.1	380	54.6
	Black	4	550	37.7	500	41.5	430	48.2	340	61.0	240	86.4
	Orange	5	415	50.0	325	63.8	225	92.2	n/a	n/a	n/a	n/a
CPG41728	Red	1	780	26.6	770	26.9	760	27.3	725	28.6	680	30.5
	Yellow	2	715	29.0	690	30.1	660	31.4	620	33.5	560	37.0
	Blue	3	620	33.5	580	35.8	520	39.9	450	46.1	380	54.6
	Black	4	550	37.7	500	41.5	430	48.2	340	61.0	240	86.4
	Orange	5	415	50.0	325	63.8	225	92.2	n/a	n/a	n/a	n/a
CPG42328	Red	1	850	33.1	833	24.9	815	25.4	803	25.8	790	26.3
	Yellow	2	750	37.5	730	28.4	710	29.2	698	29.7	685	30.3
	Blue	3	635	44.3	613	33.8	590	35.2	576	36.0	562	36.9
	Black	4	555	50.7	533	38.9	510	40.7	493	42.1	475	43.7
	Orange	5	405	51.2	378	54.9	350	59.3	328	63.2	305	68.0

Comfort Pack Gas CFM and Temperature Rise 38,000 BTU Input												
UNIT SIZE	COLOR	SPEED	.1" w.c.	TD	.2" w.c.	TD	.3" w.c.	TD	.4" w.c.	TD	.5" w.c.	TD
CPG41138	Red	1	780	36.1	770	36.6	760	37.0	725	38.8	680	41.4
	Yellow	2	715	39.4	690	40.8	660	42.6	620	45.4	560	50.3
	Blue	3	620	45.4	580	48.5	520	54.1	450	62.6	380	74.1
	Black	4	550	51.2	500	56.3	430	65.5	340	82.8	240	117.3
	Orange	5	415	67.8	325	86.6	225	125.1	n/a	n/a	n/a	n/a
CPG41738	Red	1	780	36.1	770	36.6	760	37.0	725	38.8	680	41.4
	Yellow	2	715	39.4	690	40.8	660	42.6	620	45.4	560	50.3
	Blue	3	620	45.4	580	48.5	520	54.1	450	62.6	380	74.1
	Black	4	550	51.2	500	56.3	430	65.5	340	82.8	240	117.3
	Orange	5	415	67.8	325	86.6	225	125.1	n/a	n/a	n/a	n/a
CPG42338	Red	1	850	33.1	833	33.8	815	34.5	803	35.1	790	35.6
	Yellow	2	750	37.5	730	38.6	710	39.6	698	40.3	685	41.1
	Blue	3	635	44.3	613	45.9	590	47.7	576	48.9	562	50.1
	Black	4	555	50.7	533	52.8	510	55.2	493	57.1	475	59.3
	Orange	5	405	69.5	378	74.5	350	80.4	328	85.8	305	92.3

*FACTORY SETTING

*OUTSIDE OF SYSTEM OPERATING CONDITIONS

*WITHIN OPERATING CONDITION

* ALL DATA IS APPROXIMATE, OPERATE UNIT WITHIN APPROPRIATE TEMPERATE RISE LOCATED ON PAGE 32

Installation Manual for Comfort Pack Gas Non Condensing Furnace

Comfort Pack Gas CFM and Temperature Rise 51,000 BTU Input												
UNIT SIZE	COLOR	SPEED	.1" w.c.	TD	.2" w.c.	TD	.3" w.c.	TD	.4" w.c.	TD	.5" w.c.	TD
CPG41751	Red	1	780	48.4	770	49.1	760	49.7	725	52.1	680	55.6
	Yellow	2	715	52.8	690	54.8	660	57.2	620	60.9	560	67.5
	Blue	3	620	60.9	580	65.1	520	72.6	450	84.0	380	99.4
	Black	4	550	68.7	500	75.6	430	87.9	340	111.1	240	157.4
	Orange	5	415	91.0	325	116.2	225	167.9	n/a	n/a	n/a	n/a
CPG42351	Red	1	850	44.4	833	45.4	815	46.4	803	47.0	790	47.8
	Yellow	2	750	50.4	730	51.8	710	53.2	698	54.1	685	55.2
	Blue	3	635	59.5	613	61.6	590	64.0	576	65.6	562	67.2
	Black	4	555	68.1	533	70.9	510	74.1	493	76.6	475	79.5
	Orange	5	405	93.3	378	99.9	350	107.9	328	115.2	305	123.9

Comfort Pack Gas CFM and Temperature Rise 64,000 BTU Input												
UNIT SIZE	COLOR	SPEED	.1" w.c.	TD	.2" w.c.	TD	.3" w.c.	TD	.4" w.c.	TD	.5" w.c.	TD
CPG41764	Red	1	780	60.8	770	61.6	760	62.4	725	65.4	680	69.7
	Yellow	2	715	66.3	690	68.7	660	71.8	620	76.5	560	84.7
	Blue	3	620	76.5	580	81.7	520	91.2	450	105.3	380	124.8
	Black	4	550	86.2	500	94.8	430	110.2	340	139.4	240	197.5
	Orange	5	415	76.5	325	145.9	225	210.7	n/a	n/a	n/a	n/a
CPG42364	Red	1	850	55.8	833	56.9	815	58.2	803	59.0	790	60.0
	Yellow	2	750	63.2	730	64.9	710	66.8	698	67.9	685	69.2
	Blue	3	635	74.7	613	77.3	590	80.4	576	82.3	562	84.4
	Black	4	555	85.4	533	88.9	510	93.0	493	96.2	475	99.8
	Orange	5	405	117.1	378	125.4	350	135.4	328	144.5	305	155.4

*FACTORY SETTING

*OUTSIDE OF SYSTEM OPERATING CONDITIONS

*WITHIN OPERATING CONDITION

* ALL DATA IS APPROXIMATE, OPERATE UNIT WITHIN APPROPRIATE TEMPERATE RISE LOCATED ON PAGE 32

Installation Manual for Comfort Pack Gas Non Condensing Furnace

Comfort Pack Gas 80% Air Flow Data

Model	Color	Speed Tap	ESP (in. wc) / CFM				
			0.1	0.2	0.3	0.4	0.5
CPG411	Red	1	780	770	760	725	680
	Yellow	2	715	690	660	620	560
	Blue	3	620	580	520	450	380
	Black	4	550	500	430	340	240
	Orange	5	415	325	225	X	X
CPG417	Red	1	780	770	760	725	680
	Yellow	2	715	690	660	620	560
	Blue	3	620	580	520	450	380
	Black	4	550	500	430	340	240
	Orange	5	415	325	225	X	X
CPG423	Red	1	850	833	815	803	790
	Yellow	2	750	730	710	698	685
	Blue	3	635	613	590	576	562
	Black	4	555	533	510	493	475
	Orange	5	405	378	350	328	305

Installation Manual for Comfort Pack Gas Non Condensing Furnace

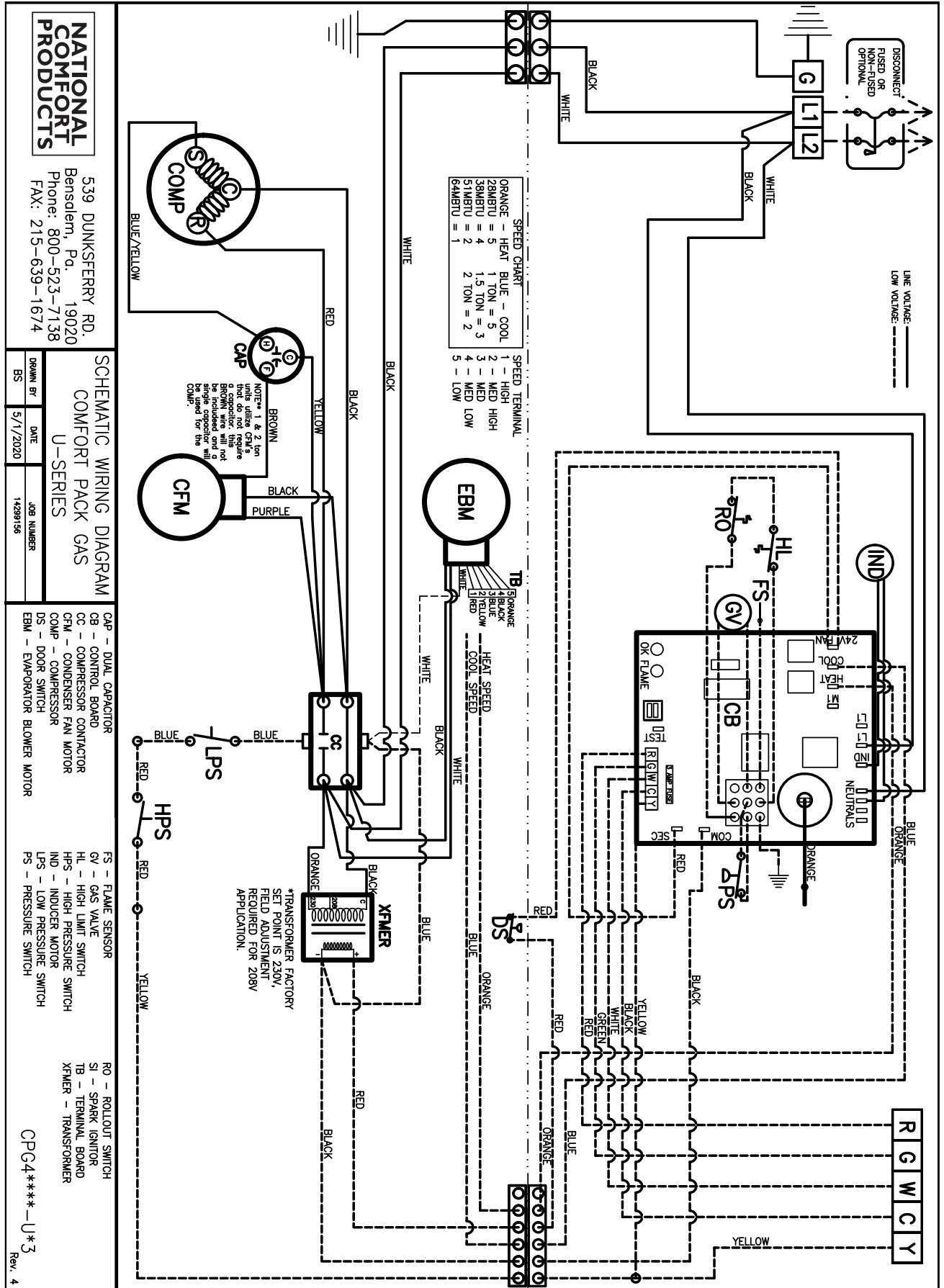

Installation Manual for Comfort Pack Gas Non Condensing Furnace

DSI INTEGRATED CONTROL MODULE	
CONTROL STATUS	GREEN LED
STEADY ON	Normal operation, no call for heat
FAST FLASH	Normal operation, call for heat
1 FLASH	In lockout from failed ignition or flame loss
2 FLASH	Pressure switch does not close for 240 seconds
3 FLASH	Limit switch or rollout switch open
4 FLASH	Pressure switch is closed before venter is energized
STEADY OFF	Internal control fault or no power
FLAME STATUS	YELLOW LED
STEADY ON	Flame sensed
SLOW FLASH	Weak flame (current below 1.0 microamps = +/-50%)
FAST FLASH	Undesired flame (valve open and no call for heat)

FAN OFF DELAY		
TIME	SWITCH	
	1	2
90	OFF	ON
120	OFF	OFF
160	ON	OFF
45	ON	ON

FIELD CONTROL WIRING		
TOTAL WIRE LENGTH	DISTANCE FROM UNIT TO CONTROL	MIN. RECOMMENDED WIRE GAUGE
150'	75'	#18 GAUGE WIRE
250'	125'	#16 GAUGE WIRE
350'	175'	#14 GAUGE WIRE

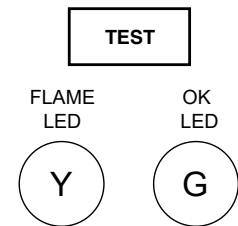

Operation Sequence

1. Set thermostat at lowest setting.
2. Turn on manual gas valve.
3. Turn on power to unit.
4. Set thermostat at desired setting.
5. Thermostat calls for heat, energizing the venter motor.
6. Venter pressure switch closes, firing unit.
7. Burner flame is sensed, and in 20 seconds the fan motor is energized.
8. If the flame is extinguished during main burner operation, the integrated control system closes the main valve and must be reset by interrupting power to the control circuit (see lighting instructions).

Notes

1. The following control is a field-installed option: thermostat.
2. Dotted wiring installed by others.
3. Caution: if any of the original wiring as supplied with the appliance must be replaced, it must be replaced with wiring material having a temperature rating of at least 105°C except for sensor lead wire and limit wiring which must be 150°C.
4. Use 18 gauge wire for all low voltage wiring on the unit or follow chart above.
5. Line and fan motor branch wire sizes should be of a size to prevent voltage drops beyond 5% of supply line voltage.
(Use copper conductors only).
6. Ground wire must be used.

Installation Manual for Comfort Pack Gas Non Condensing Furnace

TROUBLESHOOTING		
PROBLEM	PROBABLE CAUSE	REMEDY
Venter motor will not start	<ol style="list-style-type: none"> 1. No power to unit 2. No 24 volt power to integrated circuit board. 3. Integrated circuit board fuse blown. 4. Integrated circuit board defective. 5. Defective motor. 	<ol style="list-style-type: none"> 1. Turn power, check supply fuses or circuit breaker 2. Turn up thermostat; check control transformer output 3. Correct cause. Replace fuse (type ATC, 24VAC, 3A) 4. Replace integrated circuit board 5. Replace motor
Burner will not light	<ol style="list-style-type: none"> 1. Manual valve not open 2. Air in the gas line 3. Gas pressure too high or too low 4. No spark: <ol style="list-style-type: none"> a. Loose wire connections b. Transformer failure c. Incorrect spark gap. d. Spark cable shorted to ground e. Spark electrode shorted to ground f. Burner not grounded g. Circuit board not grounded h. Integrated circuit board fuse blown i. Faulty integrated circuit board 5. Lockout device interrupting control circuit by above causes 6. Faulty combustion air proving switch 7. Main valve not operating <ol style="list-style-type: none"> a. Defective valve b. Loose wire connections 8. Integrated circuit board does not power main valve <ol style="list-style-type: none"> a. Loose wire connections b. Flame sensor grounded c. Incorrect gas pressure d. Cracked ceramic at sensor 	<ol style="list-style-type: none"> 1. Open manual valve 2. Bleed gas line (initial startup only) 3. Correct supply pressure is 5" - 14" w.c. for natural gas or 11" - 14" w.c. for propane gas 4. <ol style="list-style-type: none"> a. Be certain all wire connections are solid b. Be sure 24 volts are available c. Maintain spark gap at 1/8" d. Replace worn or grounded spark cable e. Replace if ceramic spark electrode is cracked or grounded f. Make certain integrated circuit board is grounded to ignitor g. Make certain integrated circuit board is grounded to furnace chassis h. Correct cause; replace fuse (type ATC, 24VAC, 3A) i. If 24 volt is available to the integrated circuit board and all other causes have been eliminated, replace board 5. Reset lockout by interrupting control at the thermostat or main power 6. Replace combustion air proving switch 7. <ol style="list-style-type: none"> a. If 24 volt is measured at the valve connections and valve remains closes, replace valve b. Check and tighten all wiring connections 8. <ol style="list-style-type: none"> a. Check and tighten all wiring connections b. Be certain flame sensor lead is not grounded or insulation or ceramic is not cracked. Replace as required c. Correct supply pressure is 5" -14" w.c. for natural gas or 11" - 14" w.c. for propane gas d. Replace sensor
Burner cycle on and off	<ol style="list-style-type: none"> 1. Gas pressure too high or too low 2. Burner not grounded 3. Circuit board not grounded 4. Faulty integrated circuit board 5. Faulty combustion air proving switch 6. Flame sensor grounded 7. Cracked ceramic at sensor 	<ol style="list-style-type: none"> 1. Correct supply pressure is 5" -14" w.c. for natural gas or 11" - 14" w.c. for propane gas 2. Make certain integrated circuit board is grounded to ignitor 3. Make certain integrated circuit board is grounded to furnace chassis 4. If 24 volt is available to the integrated circuit board and all other causes have been eliminated, replace board 5. Replace combustion air proving switch 6. Be certain flame sensor lead is not grounded or insulation or ceramic is not cracked; Replace as required 7. Replace sensor
No heat (heater operating)	<ol style="list-style-type: none"> 1. Incorrect valve outlet pressure or orifice 2. Cycling on limit control 3. Improper thermostat location or adjustment 	<ol style="list-style-type: none"> 1. Check valve outlet pressure 2. Check air throughput 3. See thermostat manufacturer's instructions
Cold air delivered	<ol style="list-style-type: none"> 1. Incorrect valve outlet pressure 	<ol style="list-style-type: none"> 1. Check valve outlet pressure
Unit blower motor will not run	<ol style="list-style-type: none"> 1. Circuit open 2. Defective Integrated circuit board 3. Defective motor 	<ol style="list-style-type: none"> 4. Check wiring and connections 5. Replace board 6. Replace motor
Unit blower motor turns on and off while burner is operating	<ol style="list-style-type: none"> 1. Motor overload device cycling on and off 	<ol style="list-style-type: none"> 1. Check motor lead against motor rating plate; replace motor if needed
Unit blower motor cuts out on overload	<ol style="list-style-type: none"> 1. Low or high voltage supply 2. Defective motor 3. Poor air flow 4. Defective bearing or lubrication 	<ol style="list-style-type: none"> 1. Correct electric supply 2. Replace motor 3. Clean motor, fan, fan guard, filter and coils 4. Lubricate bearings or replace motor

Installation Manual for Comfort Pack Gas Non Condensing Furnace

Replacement Parts Guide

To assure accuracy when ordering replacement parts, please provide the following information:

EXAMPLE:

Unit Model:

Serial #:

Part #:

Replacement Parts Guide | Cabinet and Furnace Parts

Cabinet Parts					Furnace Parts				
Part Description	Part Number				Part Description	Part Number			
	28 MBH	38 MBH	51 MBH	64 MBH		28 MBH	38 MBH	51 MBH	64 MBH
Top Mount Angle	14256101				Gas Furnace	14208378	14208379	14208380	14208381
Top Panel	14256421				Plate Deflector Long	14256675	14256675	14256677	N/A
Patch Plate	14256422				Plate Deflector Short	14256676	14256676	14256678	N/A
Upper Intake Grille	14256438				Natural Gas Orifice	14208382	14208336	14208337	14208338
Lower Discharge Grille	14256437				LP Gas Conversion Kit	N/A	14208343	14208344	14208345
Right Side Panel	14256420				Heat Exchanger Assembly	14208329	14208329	14208330	14208331
Left Side Panel	14256419				Full Burner Body	14208332	14208332	14208333	14208334
Bottom Panel	14256600				LP Gas Orifice	N/A	14208339	14208340	14208341
Rail	14256605				Flame Rollout Switch	14208314			
Horizontal Air Divider	14256670				Orifice Adapter	14208315			
Vertical Air Divider	14256671				Orifice Adapter Lock Nut	14208316			
Cabinet Air Seal	14256813				DSI Electrode Assembly	14208317			
Indoor Blower Cover	14256812				Flame Sensor	14208318			
Blower Cover Mtg. Strap	14256811				Control Board	14208607			
Upper Front Left Panel	14256026				High Limit Control	14208320			
Upper Front Right Panel	14256027				Pressure Switch	14208324			
Furnace Filler Plate	14256028				High Altitude Pressure Switch	14208325			
Lower Access Panel	14256123-01				Combination Gas Valve	14208326			
Side Seal Retainer	14256125				Ventor Tube Assembly	14208327			
Front Air Baffle	14256665				Ventor Blade	14208347			
Front Baffle Strip	14256671				Ventor Blade & Motor Assembly	14208328			
Rear Air Baffle	14256666				Control Plug Assembly	14208335			
Rear Baffle Strip	14256667				Pressure Switch Tube	14231030			
Baffle Channel	14256664								
Mfg. Bracket - Switch	14256156								
Side Seal	14231012								
Interlock Switch	14265025								
Power Connection Pin	14230027								
Control Connection Plug	14230025								
Furnace Channel	14256663								

(Continued on next page)

Installation Manual for Comfort Pack Gas Non Condensing Furnace

Replacement Parts Guide Chassis Parts			
Part Description	Part Number		
	1 Ton	1.5 Ton	2 Ton
Chassis Model	CP41.0-UH1.1	CP41.5-UH1.1	CP42.0-UH1.1
Base Pan	14256431	14256431	14256435
Indoor Coil	14208305	14208301	14208301
Outdoor Coil	14208388	14208389	14208389
Compressor	14210249	14210251	14210252
Compressor Accessories	RECHI 272 ACCESS	RECHI 382 ACCESS	RECHI 492 ACCESS
Capacitor	14225387	14225395	14225397
TXV	14275100	14275117	14275118
Outdoor Fan Motor	14270057	14270044	14270057
Outdoor Coil Mount	14256430	14256434	
Drier	14275947		
Outdoor Fan	14214042		
Outdoor Motor Mount	14270101		
Indoor Blower Motor	14270055		14270059
Blower Wheel	14214022		
Blower Housing	14214023		
Indoor Motor Mount	14270105		
Air Divider	14256415		
Indoor Coil Cover	14256647		
Indoor Coil Drain Pan	14256098		
Air Filter	14232002		
Wire Harness Controls	14230024		
Power Connection Plug	14230026		
Compressor Harness	14230057		
Contactora	14262082		
Transformer 208/240-24V	14262087		
5-Pole Terminal Board	14263062		
Low Pressure Switch	14265026		
High Pressure Switch	14265029		
3/4" ID Drain Tube	14275616		



IMPORTANT!!!

**BEFORE REMOVING A WARRANTY COMPRESSOR,
PLEASE FILL OUT THE FOLLOWING
AND CALL (800) 523-7138.**

**REMOVAL OF COMPRESSOR WITHOUT FACTORY VERIFICATION
CAN LEAD TO WARRANTY CREDIT BEING DENIED**

1. Incoming Voltage to Compressor at Contactor is: _____ Volts AC \sim
2. Compressor Starting AMP Draw: _____ $\frac{R}{R}$
3. Compressor Winding OHM Reading between Terminals C & S: _____ Ω
4. Compressor Winding OHM Reading between Terminals C & R: _____ Ω
5. Compressor Winding OHM Reading between Terminals R & S: _____ Ω
6. Compressor Winding OHM Reading between Terminals C & Ground: _____ Ω
7. Compressor Winding OHM Reading between Terminals R & Ground: _____ Ω
8. Compressor Winding OHM Reading between Terminals S & Ground: _____ Ω

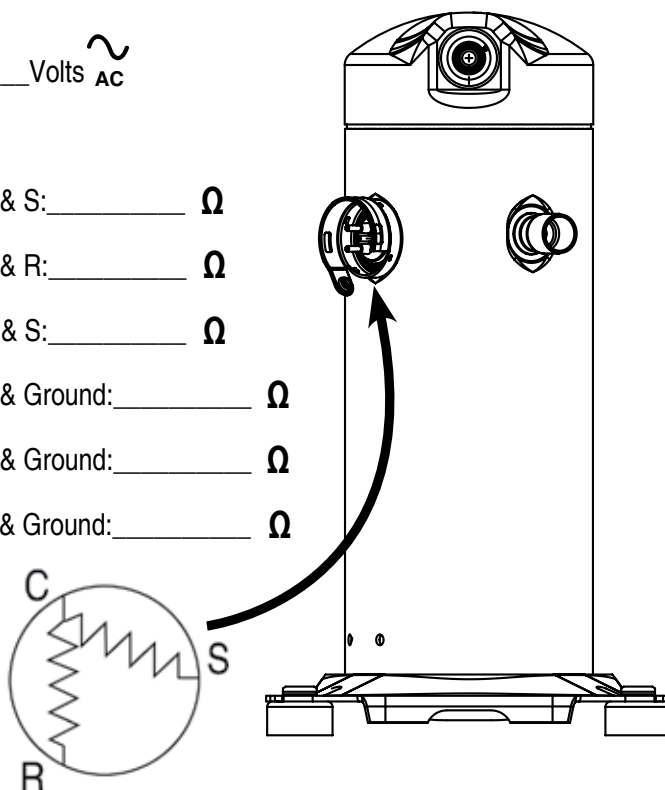

9. Run Capacitor Reading from HERM to COM: _____ $\frac{+}{\mu F}$
10. Start Capacitor Reading if Used: _____ $\frac{+}{\mu F}$

TOP VIEW OF CAPACITOR

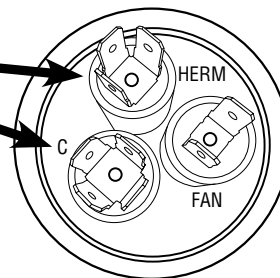

11. If the Compressor is Operating Please Indicate the Following:

Suction Pressure: _____ psig Discharge Pressure: _____ psig
 Super Heat: _____ F Subcooling: _____ F



A Division of National Refrigeration & Air Conditioning Products, Inc.

539 Dunksferry Road | Bensalem, PA 19020 | 215-244-1400 | 1-800-523-7138 | Fax: 215-639-1674

COMFORT PACK LIMITED WARRANTY

1. National Comfort Products warrants to its customers that its product shall be free from defects in material and workmanship under normal use and regular service and maintenance as follows:

HEAT EXCHANGERS (Gas units only): for ten years from the date of original installation.

ALL OTHER PARTS: For all other parts except the Heat Exchanger, for five years from the date of original installation.

Customer must register the product within 60 days of purchase. If Customer cannot adequately document date of installation, then, for purposes of determining the warranty period, the date of installation shall be 60 days from the date of purchase.

2. This warranty does not extend to any damages or losses due to misuse, accident, abuse, neglect, normal wear and tear, negligence (other than National Comfort's), unauthorized modification or alteration; use beyond rated capacity; unsuitable power sources or environmental conditions; improper installation, repair, handling, maintenance or application; damage as a result of fire, wind, floods, lightning, or corrosive conditions; or any other cause not the fault of National Comfort. By way of example and without limitation, the following do not constitute a defect in workmanship and materials and are not covered by this warranty: slugging of liquid refrigerant or oil, unstable line voltage, lightning, operating without proper lubrication, and operating without factory provided safeties. Any installation that impairs or impedes air flow negatively impacts performance and causes premature equipment failure that voids this warranty. For example, installation behind a brick façade or the addition of a brick pattern façade, i.e. pigeon holes impedes air flow and shall void this warranty. No warranty will apply if the input section exceeds the rated input as indicated on the nameplate by more than 5%, or if the heat section in the judgement of the manufacture has been subject to misuse, negligence, accident, corrosive atmospheres, atmospheres contacting any contaminant (silicone, aluminum oxide, etc.), excessive thermal shock, physical damage, impact, abrasion, unauthorized alterations, or operation contrary to the manufacture's printed instructions, or if the serial number has been altered, defaced, or removed.

3. SOLE WARRANTY

The warranties identified herein constitute National Comfort's sole and exclusive warranties with respect to the goods and are in lieu of and exclude all other warranties, express or implied, arising by operation of law or otherwise, including without limitation, merchantability and fitness for a particular purpose whether or not the purpose or use has been disclosed to National Comfort in specifications, drawings or otherwise, and whether or not National Comfort's goods are specifically designed and/or manufactured by National Comfort for Customer's use or purpose.

4. LIMITATION OF REMEDY

The sole and exclusive remedy for breach of any warranty hereunder (other than the warranty provided herein) shall be limited to repair, replacement, credit or refund of the purchase price to distribution as set forth herein.

National Comfort is not responsible for any other item including but not limited to local transportation, freight, removal of any compressor or part, any labor associated therewith, service or diagnosis calls, refrigerant, or costs for returning any defective compressor or part.

5. LIMITATION OF WARRANTY

NATIONAL COMFORT MAKES NO OTHER WARRANTIES, EXPRESS OR IMPLIED, ORAL OR WRITTEN, RELATED TO THE GOODS, INCLUDING ANY WARRANTY OF MERCHANTABILITY OF FITNESS FOR A PARTICULAR PURPOSE, WHICH ARE EXPRESSLY DISCLAIMED. NATIONAL COMFORT SHALL NOT BE LIABLE FOR SPECIAL, INCIDENTAL, OR CONSEQUENTIAL DAMAGES OR LOSSES FROM ANY CAUSE WHATSOEVER, INCLUDING, WITHOUT LIMITATION, LOSS OF USE, COMMERCIAL PROFITS, OR CUSTOMER GOODWILL, AND ANY OTHER CLAIMS BASED ON CONTRACT OR TORT, WHETHER OR NOT ARISING FROM NATIONAL COMFORT'S NEGLIGENCE.

National Comfort shall not be liable for damages caused by delay in performance and the remedies of Customer set forth in this agreement are exclusive. In no event, regardless of the form of the claim or cause of action (whether based in contract, infringement, negligence, strict liability, other tort or otherwise) shall National Comfort's liability to Customer and/or its customers exceed the price paid by Customer for the specific goods or portion of the goods provided by National Comfort giving rise to the claim or cause of action, and Customer shall indemnify and hold harmless National Comfort for any damages incurred by National Comfort in excess thereof. Customer agrees that in no event shall National Comfort's liability to Customer and/or its customers extend to include incidental, consequential, or punitive damages.

Continued on next page

Installation Manual for Comfort Pack Gas Non Condensing Furnace

The term “consequential damages” shall include, but not be limited to, loss of anticipated profits, business interruption, loss of use, revenue, reputation and data, costs incurred, including without limitation, for capital, fuel, power and loss or damage to capital or equipment. Customer agrees that all instructions and warnings supplied by National Comfort will be passed on to those persons who use the Goods. National Comfort’s Goods are to be used in their recommended applications and all warning labels adhered to the Goods by National Comfort are to be left intact.

It is expressly understood that any technical advice furnished by National Comfort before or after delivery in regard to the use or application of the Goods is furnished without charge, and National Comfort assumes no obligation or liability for the advice given or results obtained, all advice being given and accepted at Customer’s sole risk.

6. WARRANTY PROCEDURE

For All Warranty Claims. Customer must register the product with National Comfort within 60 days from purchase. Failure to timely register the product may void the warranty. Any claim for warranty shall be made within thirty days of discovery and in any event, within thirty days from removal of the compressor or part from the unit. Failure to make a timely claim shall void the warranty. Prior authorization from National Comfort is required for all warranty claims. Any claim for warranty must be first reported to National Comfort in writing specifying the unit, serial number, date of purchase and date of original installation. Customer shall also request a Return Material Authorization (“RMA”) from National Comfort to initiate the warranty claim process. Issuance of an RMA by National Comfort is not an acknowledgment that the defect is covered by this Warranty. Any replacement compressor or part is warranted for the original product warranty, or for one year from the date of shipment of the replacement compressor/part, whichever is later.

A. Heat Exchangers. In addition to the above-reference requirements, customer is also required to purchase a replacement heat exchanger and return the original heat exchanger to National Comfort at National’s discretion, freight prepaid. If National Comfort determines that there is a defect in material or workmanship in the heat exchanger that is covered by this Warranty, then National Comfort shall credit Customer for the cost of the new replacement heat exchanger. If National Comfort determines that the defect in material or workmanship is not covered by this Warranty, then no credit shall be issued. A copy of the invoice of the replacement heat exchanger and completed RMA must accompany the original heat exchanger for which warranty is claimed. National Comfort reserves the right to request additional documentation. The failure to follow this procedure shall render the warranty void. .

B. Compressors. In addition to the above-referenced requirements, Customer is also required to purchase a replacement compressor and return the original compressor to National Comfort at National’s discretion. If the defect is reported to National Comfort within one year from the date of original installation or within 20 months from the date of manufacture of the compressor (as determined by the compressor serial number), whichever occurs first, then Customer may take the compressor to any Authorized Copeland Distributor for replacement of said compressor. If the defect is reported to National Comfort after one year from the date of installation or after 20 months from the date of manufacture of the compressor (as determined by the compressor serial number), whichever occurs first, but before the expiration of five years from the date of installation, then the compressor should be returned to National Comfort at National’s discretion and Customer shall purchase a new compressor. If National Comfort determines that there is a defect in material or workmanship that is covered by this Warranty, then National shall credit Customer for the cost of the new replacement compressor. If National Comfort determines that the defect in material or workmanship is not covered by this Warranty, then no credit shall be issued. A copy of the invoice of the replacement compressor and completed RMA must accompany the compressor. National Comfort, at its sole discretion, may also require Customer to supply the compressor tag. The failure to follow this procedure shall render the warranty void.

B. Other Parts. In addition to the above-referenced requirements, Customer is required to purchase a replacement part for the original part for which Customer is making a warranty claim. The original part for which warranty is claimed is to be returned to National Comfort at National’s discretion, freight prepaid. If National Comfort determines that there is a defect in material or workmanship in the part that is covered by this Warranty, then National Comfort shall credit Customer for the cost of the new replacement part. If National Comfort determines that the defect in material or workmanship is not covered by this Warranty, then no credit shall be issued. A copy of the invoice of the replacement part and completed RMA must accompany the original part for which warranty is claimed. National Comfort reserves the right to request additional documentation. The failure to follow this procedure shall render the warranty void.

7. SHIPPING INSTRUCTIONS

A. Compressors. Returned compressors must be totally secured by use of shipping lugs taken from the replacements compressors and clearly marked with the RMA number. Do not use tape, rags or putty to seal the compressor. Line connections should be sealed with rubber plugs. All scroll compressors must be securely bolted, banded, and stretch wrapped to a skid in the upright position.

B. Parts. All other returned parts must be securely packaged and clearly marked with its corresponding RMA number provided from NCP.



**NATIONAL
COMFORT
PRODUCTS**
HEATING & A/C EQUIPMENT

National Comfort Products®
A Division of National Refrigeration & Air Conditioning Products, Inc.

539 Dunksferry Road | Bensalem, PA 19020

1-800-523-7138 | Fax: (215) 639-1674

www.NationalComfortProducts.com

