

LOW PROFILE BASE

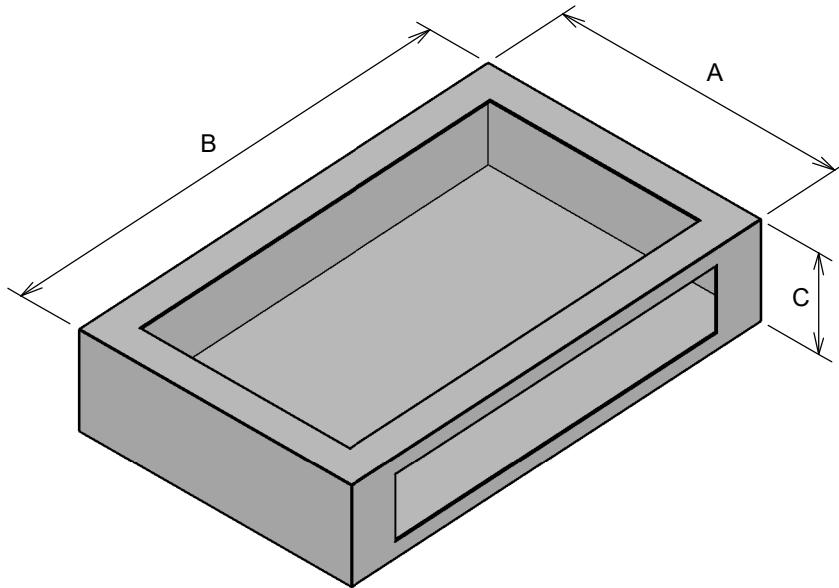

	Dimension A (Width)	Dimension B (Depth)	Dimension C (Height)
RAB Low Profile 14	14"	28.5"	6"
RAB Low Profile 17.5	17.5"	28.5"	6"
RAB Low Profile 21	21"	28.5"	6"
RAB Low Profile 24.5	24.5"	28.5"	6"

- For residential and commercial applications
- Constructed with heavy gauge galvanized steel
- Reversible for left or right installation
- Raises furnace for easier service
- Maximizes airflow by utilizing both bottom and side return to prevent equipment failure (including hi-limit, cracked heat exchanger and premature motor failure) due to restricted air flow
- Great for retrofit and new construction installation
- Can improve airflow throughout duct system
- Improves furnace performance and reduces noise issues