

## 50001194-001 Foot Mount Kit FOR DIRECT COUPLED ACTUATORS

### INSTALLATION INSTRUCTIONS

## APPLICATION

The 50001194-001 Foot Mount Kit is designed for applications where a direct coupled actuator (DCA) will not be mounted directly to the damper shaft. It can be used for both external and internal duct mounting. The kit is designed to mount a wide variety of Honeywell and non-Honeywell actuators in the same mounting locations as common foot-mounted or remote-mounted actuators. See Table 1 for compatibility. The foot mount bracket includes mounting hole patterns to match common Honeywell, Siebe™, Barber-Colman™, Invensys™, and Johnson Controls® actuators for easy retrofit. See Fig. 2.

**Table 1. Actuator Compatibility.**

Compatible Direct Coupled Actuator Families				
Belimo™	Honeywell			Siemens™
NF	MLXX84	MN6120	MS4105, MS4110, MS4120	GMA
AF	MLXX94	MN6134	MS4605, MS4610, MS4620	GEB
AM	MLXX75	MN7220	MS7505, MS7510, MS7520	GCA
	MLXX85	MN7234	MS8105, MS8110, MS8120	GBB
	MLXX95	N20	S05, S10, S20	GIB
		N34		

**Dimensions:** See Fig. 1.

**Operating Temperature:** -40 to 140°F (-40 to 60°C).

### Accessories:

#### Ball Joints:

- 27518 Ball Joint (5/16 in. diameter hole).
- 103598 Ball Joint (1/4 in. diameter hole).

#### Push Rods (5/16 in. diameter):

- 27520A Push Rod (5 in. long).
- 27520B Push Rod (10 in. long).
- 27520C Push Rod (12 in. long).
- 27520D Push Rod (15 in. long).
- 27520E Push Rod (18 in. long).
- 27520G Push Rod (24 in. long).
- 27520H Push Rod (28 in. long).
- 27520J Push Rod (32 in. long).
- 27520K Push Rod (36 in. long).
- 27520L Push Rod (48 in. long).
- 27520Q Push Rod (8 in. long).

### Package Contents (see Fig. 3):

- Self-tapping mounting screws (2).
- Foot mount bracket.
- Bronze bearings (2).
- Crank arm and Drive shaft (single assembly).
- Shaft collar.

#### Mounting Brackets:

- 205649 Mounting Bracket for 150 and 300 lb-in. non-spring and spring return actuators.
- 205784 Mounting Bracket for 25 and 53 lb-in. spring return actuators ("ML" Series).

#### Self-Centering Shaft Adapters:

- 32004254-001 Self-Centering Shaft Adapter for N20.
- 32004254-002 Self-Centering Shaft Adapter for S05, S10, S20.
- 32004254-003 Self-Centering Shaft Adapter for N34.

- 26026G Damper Crank Arm, 1/2 in. damper shaft.
- 32007205-002 Damper Blade Drive Lever (small).
- 32007205-003 Damper Blade Drive Lever (large).



## INSTALLATION

### When Installing this Product...

1. Read these instructions carefully. Failure to follow them could damage the product or cause a hazardous condition.
2. Check ratings given in instructions and on the product to ensure the product is suitable for your application.
3. Installer must be a trained, experienced service technician.
4. After installation is complete, check out product operation as provided in these instructions.

### IMPORTANT

*Always conduct a thorough checkout when installation is complete.*

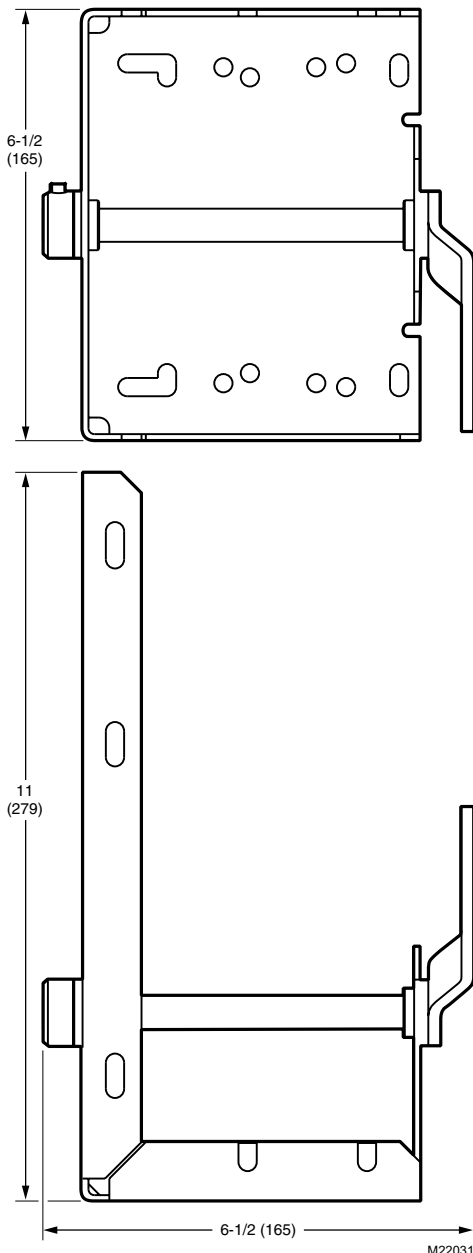

**Fig. 1. Dimensions in in. (mm).**

### Location

Allow enough clearance for installing accessories and actuator servicing when selecting a location (see Fig. 1).

Position the foot mount bracket in:

- New Installations: Planned mounting location.
- Replacing Common Foot-Mount Actuators: Align the bolt pattern with the previous actuator pattern.

### Mounting

Mount the foot mount bracket, actuator, and linkage as follows:

NOTE: Refer to actuator installation literature for further details.

1. Prepare the foot mount bracket by inserting the brass bearings. See Fig. 3
2. Identify the correct anti-rotation hole pattern for the actuator. See Fig. 4.
3. Position the actuator anti-rotation bracket over the desired hole pattern. Mount the anti-rotation bracket using #10 sheet metal screws (provided).

NOTE: It may be required to remove excess portions of the anti-rotation bracket.

4. Place the actuator in the foot mount bracket, properly aligning it relative to the anti-rotation bracket.

NOTE: When using spring return actuators, select proper mounting orientation to achieve desired spring return operation. (Refer to actuator installation literature.)

5. Insert the shaft and crankarm assembly through the bearings and the actuator shaft adapter.
6. Place the collar onto the crankarm shaft and tighten the set screw.
7. Rotate crankarm to the required operating position.
8. Tighten the actuator shaft adapter to the shaft.
9. Position the foot mount bracket/actuator assembly in the best position for proper crankarm/linkage alignment.
10. Mark the foot mount bracket position.
11. Remove the actuator.
12. Fasten the foot mount bracket to the mounting surface.
13. Repeat steps 4 through 8 to mount the actuator.
14. Install the linkage assembly between the damper and actuator crankarms.
15. Cycle the actuator through its operational range to verify correct linkage setup.

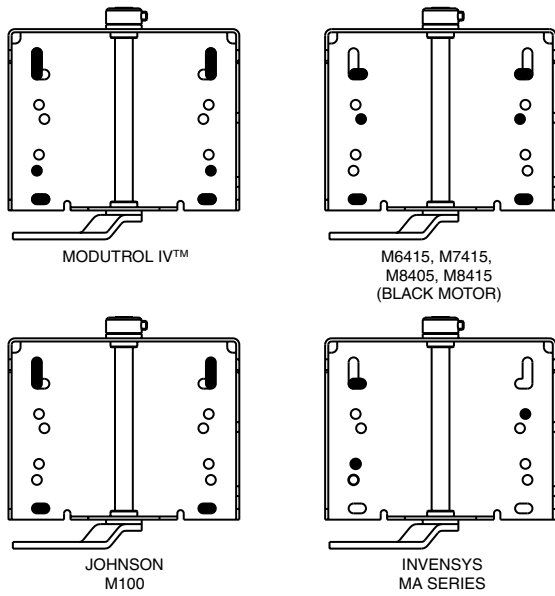

NOTE: DARK AREAS REPRESENT MOUNTING BOLT LOCATIONS THAT EXIST FOR THE INDICATED FAMILY OF MOTORS.

M22029

**Fig. 2. Foot-mount hole usage.**

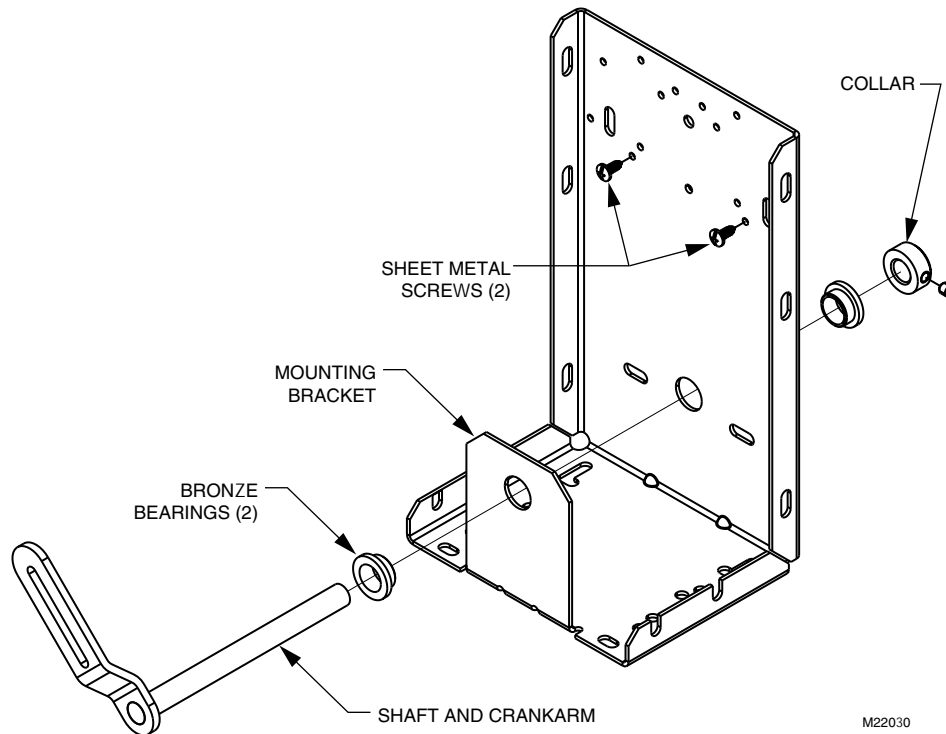

M22030

**Fig. 3. Mounting kit exploded view.**

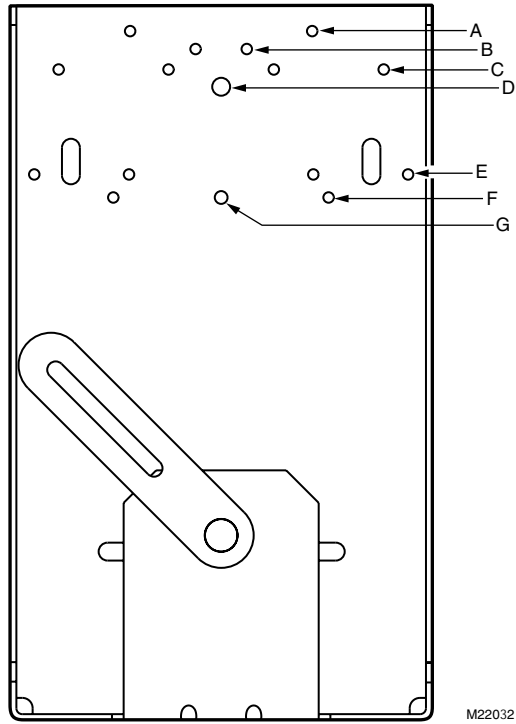

M22032

Holes	For Use with Direct Coupled Actuator
A	ML7295 and Siemens GCA, GBB, GIB
B	Belimo NF, AF
C	S05, S10, S20 Series (MS41XX, MS46XX, MS75XX, MS81XX) and ML7285, ML7284
D	S05, S10, S20 Series using 1/4-20 bolt for anti-rotation
E	Siemens GMA/GEB
F	MN6120, MN6134, MN7220, MN7234, N20, N34 and Belimo AM
G	MN6120, MN6134, MN7220, MN7234, N20, N34 and Belimo AM using #10 bolt for anti-rotation

Fig. 4. Anti-rotation bracket mounting holes.

*Invensys™, Barber-Colman™ and Siebe™ are trademarks of Invensys Building Systems, Inc.*

*Belimo™ is a trademark of Belimo Air Controls, Inc.*

*Johnson Controls® is a registered trademark of Johnson Controls, Inc.*

*Siemens™ is a trademark of Siemens Building Technologies, Inc.*

**Honeywell**

**Automation and Control Solutions**

Honeywell International Inc.  
1985 Douglas Drive North  
Golden Valley, MN 55422

Honeywell Limited-Honeywell Limitée  
35 Dynamic Drive  
Scarborough, Ontario  
M1V 4Z9

By using this Honeywell literature, you agree that Honeywell will have no liability for any damages arising out of your use or modification to, the literature. You will defend and indemnify Honeywell, its affiliates and subsidiaries, from and against any liability, cost, or damages, including attorneys' fees, arising out of, or resulting from, any modification to the literature by you.