



MT VERNON, OH 43050
800-253-8236

SPECIFICATION DATA SHEET

DATE: 7-16-13
PREPARED BY: RL

MODEL NO. 242 SIDE TAKEOFF WITH DAMPER

Standard Model - CENTERED

DIMENSIONS

SIZE								
A	x	B	x	C	D	E	F	G
6"	x	7"	x	4"	8"	9"	4 1/4"	7 1/4"
6"	x	7"	x	5"	8"	9"	4 1/4"	7 1/4"
6"	x	7"	x	6"	8"	9"	4 1/4"	7 1/4"
6"	x	7"	x	7"	8"	9"	4 1/4"	8 1/4"

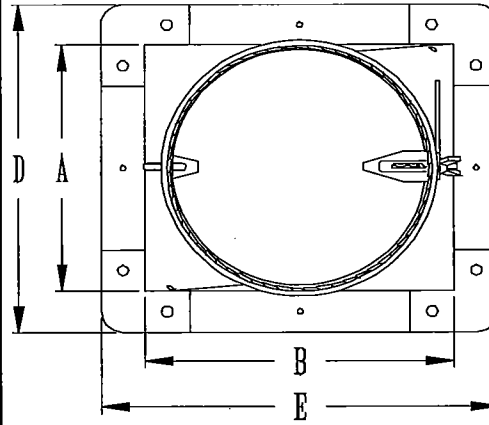

MATERIAL SPECIFICATIONS

HOT DIPPED GALVANIZED STEEL.
PER ASTM A 653 CSB.

BODY & COLLAR GAUGE: 4" - 8" COLLAR = STD GA
9" - 14" COLLAR = 28 GA

DAMPER GAUGE: 4"-8" = 28GA
9"-12" = 26GA
14" = 24GA

ASSEMBLED WITH 1/8" ZINC COATED RIVETS.

WINGNUT: 5/16-18, ZINC PLATED STEEL

DAMPER HANDLE : 18 GA

GASKET IS CROSSLINKED POLYETHYLENE.

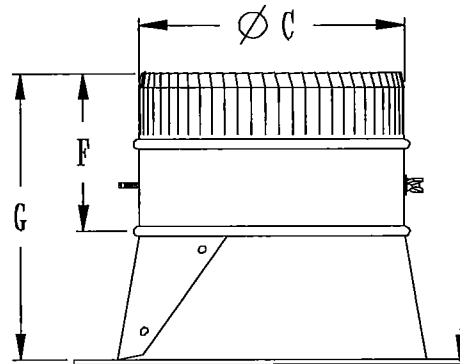

1/8" Thick Gasket

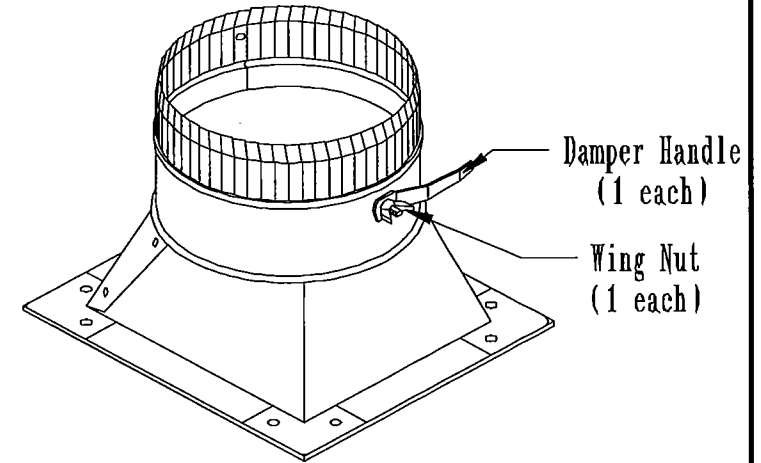

OPTIONS

JOB: _____
 LOCATION: _____
 CONTRACTOR: _____
 ENGINEER: _____
 NOTES: _____



325 COMMERCE DRIVE
 MT VERNON, OH 43050
 800-253-8236

SPECIFICATION DATA SHEET

DATE: 7-16-13
 PREPARED BY: RL

MODEL NO. 242 SIDE TAKEOFF WITH DAMPER

Standard Model - ECCENTRIC

DIMENSIONS

SIZE								
A	x	B	x	C	D	E	F	G
7"	x	16"	x	10"	9"	18"	4 1/4"	10 1/4"
8"	x	10"	x	6"	10"	12"	4 1/4"	7 3/4"
8"	x	12"	x	8"	10"	14"	4 1/4"	10 1/4"
8"	x	12"	x	9"	10"	14"	4 1/4"	10 1/4"
9"	x	18"	x	12"	11"	20"	4 1/4"	10 1/4"
10"	x	10"	x	8"	12"	12"	4 1/4"	10 1/4"
10"	x	12"	x	10"	12"	14"	4 1/4"	10 1/4"
10"	x	20"	x	14"	12"	22"	4 1/4"	11 1/4"

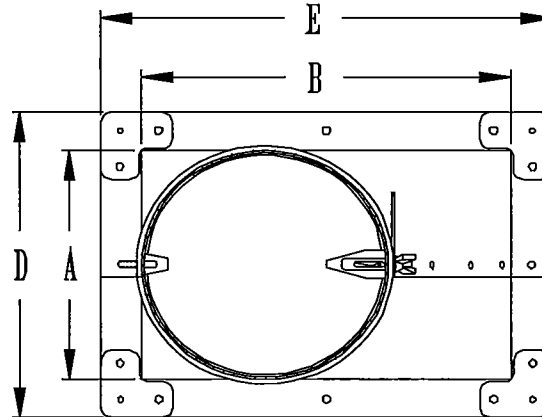

MATERIAL SPECIFICATIONS

HOT DIPPED GALVANIZED STEEL.
 PER ASTM A 653 CSB.

BODY & COLLAR GAUGE: 4" - 8" COLLAR = STD GA
 9" - 14" COLLAR = 28 GA

DAMPER GAUGE: 4"-8" = 28GA
 9"-12" = 26GA
 14" = 24GA

ASSEMBLED WITH 1/8" ZINC COATED RIVETS.

WINGNUT: 5/16-18, ZINC PLATED STEEL

DAMPER HANDLE : 18 GA

GASKET IS CROSSLINKED POLYETHYLENE.

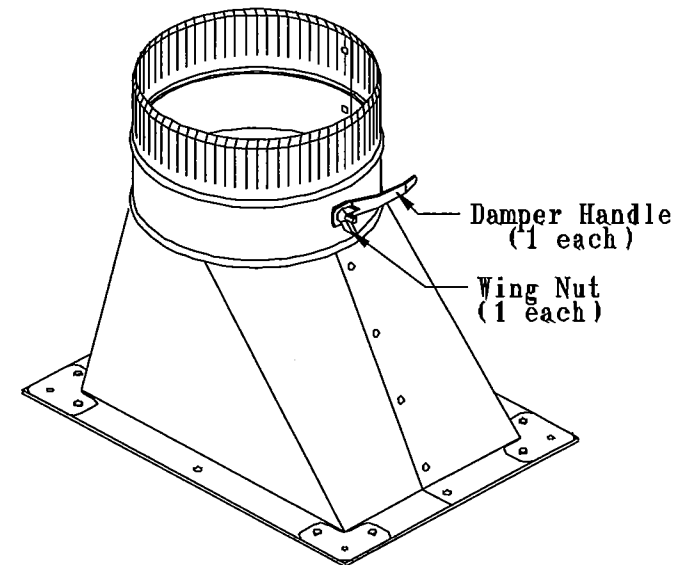
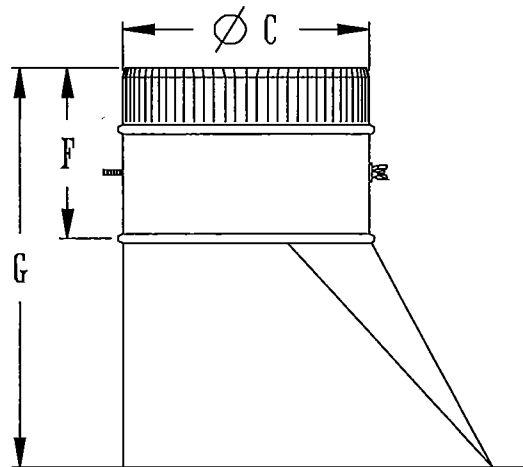

OPTIONS

JOB: _____
 LOCATION: _____
 CONTRACTOR: _____
 ENGINEER: _____
 NOTES: _____