



MAKE UP AIR KIT BAROMETRIC DAMPER + INTAKE HOOD MODEL #SKTL-KIT

FOR USE

- Balancing and adjusting airflow in residential and commercial HVAC systems through an air pressure activated damper

MATERIALS

- DAMPER: Single blade damper made from galvanized steel
- INTAKE HOOD: Screened intake vent made from galvanized steel
- Quality Constructed from 28 -22 gauge Galvanized Steel

FEATURES

- Damper remains closed when furnace is not in operation, preventing unwanted air infiltration
- Weighted swing arm will open when the system is in operation, drawing in fresh air, balancing air quality in the home
- Weights can be adjusted to desired airflow or barometric pressure to ensure slight positive pressure within the home
- Damper is connected via ducting to a screened 6" or 8" intake vent
- Included intake vent hood is screened, keeping out birds and pests

BENEFITS

- Maintains indoor air quality and reduces drafts by keeping the HVAC system balanced, only allowing in fresh air when needed
- Easily adjusted weights allow for precise damper activation
- Hood and damper conveniently in one kit for ease of installation

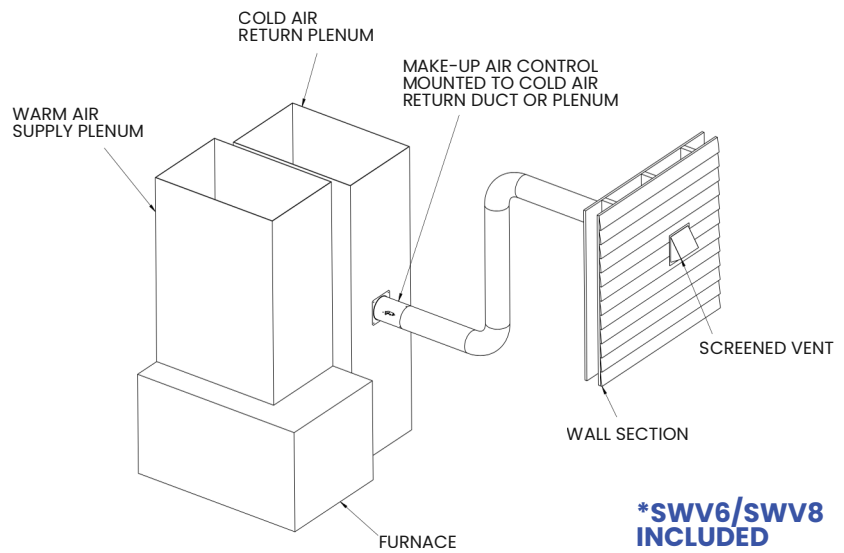
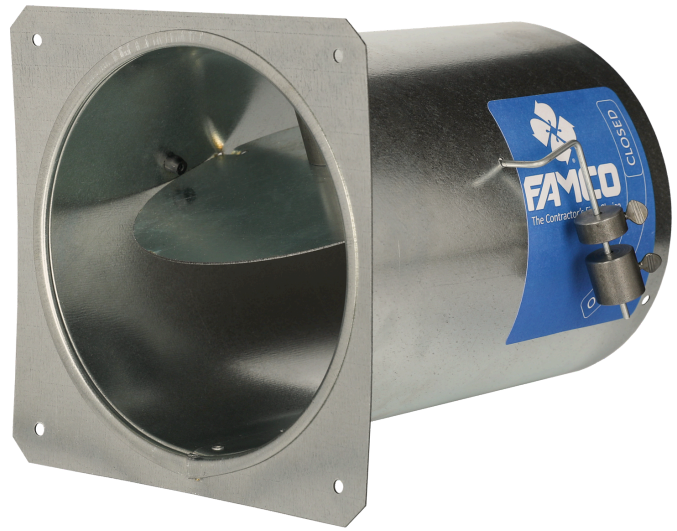

***SWV6/SWV8 INCLUDED**

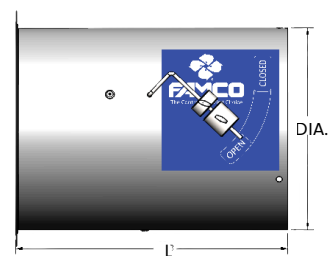
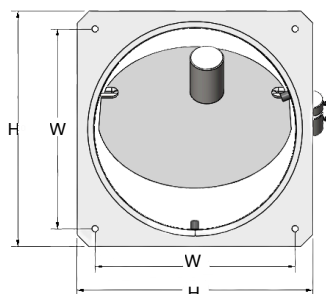

SKU	W	H	L	DIA.	CFM @ 0.05 in.	CFM @ 0.10 in.
SKTL6-KIT	5.94"	7.00"	8.08"	6	167	234
SKTL8-KIT	7.94"	9.00"	8.06"	8	296	416