



WWW.ATMOPHERE.COM

INDUSTRY'S MOST POWERFUL INLINE FANS

When these high performance inline duct blowers were conceived, reliability and efficiency were the main goals. Its more powerful motor combined with its aerodynamically designed shape make Vortex Powerfans the performance leader in its category.

Never seen in the ventilation industry, the Vortex Powerfan VTX Series feature a 10 year warranty.



Easy installation

The VTX Series feature an extended collar and lip allowing easy duct hook-up.

- Brackets included for wall or ceiling mount

Maintenance Free Operation

All VTX Series are made of heavy gauge steel casing with a hammertone powder coat finish making it more sound absorbing, durable and rust proof.

- Permanently lubricated sealed bearings
- External rotor motor with automatic reset thermal overload protection
- Suitable for airstream temperatures up to 140°F (60°C)
- 10 year warranty
- ETL Listed

Features and Benefits

- 4" to 12" duct diameters
- From 198 to 1124 CFM
- Aerodynamic design allowing more air flow
- 100% speed controllable easing air flow adjustment
- Prewired with 120V power cord
- AMCA Air Listed

Typical Residential Applications

Inline fans enhance air quality and reduce point source pollutants in a variety of indoor spaces, such as damp basements, crawl spaces, attics, etc.

Kitchen ventilation

Proper kitchen ventilation is the key to reduce cooking odors, smoke, contaminants and moisture. An inline fan connected to your range hood will increase exhaust performance and ensure clean air in the kitchen area.

Bathroom ventilation

Moisture buildup can create structural damages and cause growth of mold mildew and bacteria. The VTX Series is an efficient and quiet solution for proper bathroom ventilation.

Duct boosting

Inline Fans are ideal for ventilating a new addition or for improving the efficiency of an existing air system.

Garage ventilation

Inline Fans are ideal for removing harmful car fumes and pollutants.

Dryer booster

Ideal clothing dryer venting arrangements with short duct length are often not possible. An inline vent boosting blower is a common solution to this problem.

VTX Series View & Sizes

All dimensions in inches

FAN MODEL	Weight (lbs)**	A*	B	C
VTX400	7.4	4.0	8.5	9.5
VTX600L	8.8	6.0	8.5	9.5
VTX600	10.8	6.0	10.5	13.0
VTX800L	12.0	8.0	10.5	13.0
VTX800	12.2	8.0	10.5	13.0
VTX1000	12.4	10.0	10.5	13.0
VTX1200L	14.4	12.0	12.3	16.0
VTX1200	14.6	12.0	12.3	16.0

** Mounting Brackets included

* Represents Duct Dimensions

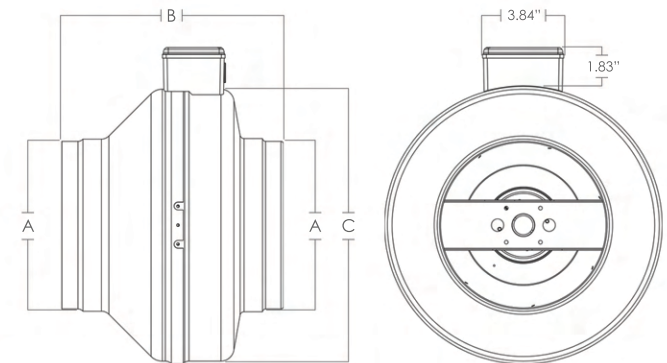

VTX Series Air Performance Graph

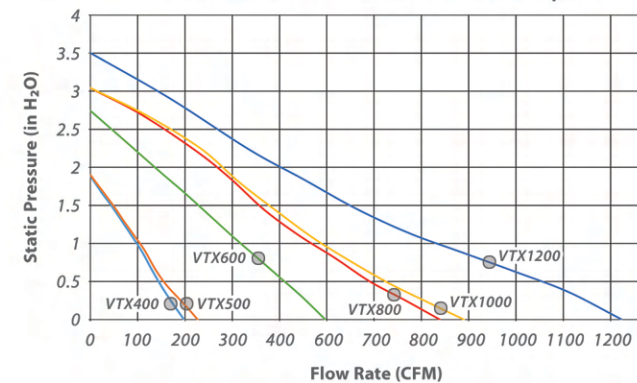

VTX Series "L" Air Performance Graph

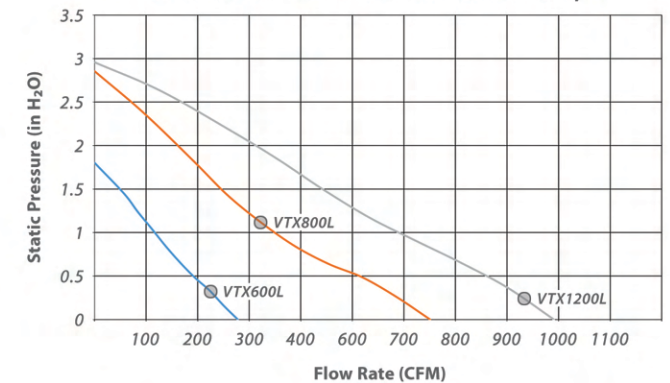

VTX Series Performance Data

ALL VTX PRODUCTS INCORPORATE MOTORS SUITABLE FOR 120 Volts AC 60Hz ELECTRICAL SUPPLY ONLY

FAN MODEL	Duct Dia.	RPM	Volts	Rated Watts	Max Amps	Static Pressure in Inches W.G.											Max Ps
						0"	0.125"	0.2"	0.25"	0.375"	0.5"	0.75"	1"	1.25"	1.5"	2"	
VTX400	4"	2970	120	69	0,57	198	184	175	170	157	144	122	98	71	15	---	1.885"
VTX600L	6"	2950	120	70	0,58	278	256	244	237	215	191	152	117	82	50	---	1.803"
VTX600	6"	3050	120	140	1,28	497	477	465	456	434	411	364	318	273	229	136	2.744"
VTX800L	8"	3000	120	196	1,62	651	621	602	588	555	513	416	349	294	245	162	2.856"
VTX800	8"	3060	120	260	2,29	739	703	681	667	628	591	531	468	408	357	268	3.042"
VTX1000	10"	3070	120	273	2,28	791	748	723	706	664	624	555	489	431	378	280	3.044"
VTX1200L	12"	2970	120	272	2,26	892	864	846	833	799	761	677	590	510	442	313	2.958"
VTX1200	12"	2820	120	393	3,26	1124	1090	1067	1051	1006	954	845	733	631	549	404	3.503"

Performance certified is for installation type D - Ducted inlet, Ducted outlet. Speed (RPM) shown is nominal. Performance is based on actual speed of test. Performance ratings include the effects of appurtenances (accessories) Inlet Duct, Inlet Bell, Outlet Duct



2480 Boul. des Entreprises Terrebonne, Quebec J6X 4J8 CANADA
T: 450.477.1100 F: 514.313.5700 TF: 1.800.489.1301
WWW.ATMOSPHERE.COM

FEBRUARY 2020

Customer support : info@atmosphere.com
Sales inquiries : sales@atmosphere.com

Panasonic is the exclusive distributor of Atmosphere products in the US

Panasonic IAQ Division For Order Information
Two Riverfront Plaza PHONE: 866-292-7299
Newark, NJ 07102 FAX: 888-553-0723
na.panasonic.com/us/iaq ventfans@us.panasonic.com

Design and specifications subject to change without notice.

Pending AMCA Certification