

Specification Submittal Data / Panasonic Mirror Model ERV

Description

Ceiling or wall mount mirror model Energy Recovery Ventilator (ERV) for any climate provides a tempered air supply, humidity control, and a balanced amount of exhaust to help maintain balanced, positive or negative pressure throughout the home. The Panasonic Intelli-Balance ERV is engineered for use in any North America climate zone. Version 2 includes new Hi/Lo Occupant Controlled Boost Capability. Built-in ASHRAE 62.2 Timing function helps ensure code compliance when used as an intermittent air change strategy.

Motor/Blower:

- ERV Supply and Exhaust ventilation rates shall be manually adjustable for 30-50-60-70-80-90-100 CFM.
- ERV shall have Hi/Lo Speed; occupant controlled Control Boost Capability up to 100 CFM
- Two (2) enclosed DC brushless motors rated for continuous run.
- Power rating shall be 120 volts and 60 Hz.
- Motor equipped with thermal cut-off fuse control.
- Removable, permanently lubricated, plug-in motor.

Housing:

- 22 gauge galvanized steel body.
- Four 4" or 6" intake and exhaust ducts.
- Built in dampers on exhaust and Outdoor Air ducts for defrost and recirculation cycling.
- Filters on supply and exhaust air extend the life of the ERV core.
- (4) Pressure ports allow for easy airflow verification.
- Pre-drilled mounting bracket can accommodate 16", 19", or 24" on center.

Maintenance:

- MERV 8 filter included; MERV 8 (FVFL0810VE1) and optional MERV 13 (FVFL1310VE1) replacements available.
- Unobtrusive alarm notifies owner for filter check and maintenance.

Warranty:

- DC Motors: 6 years from original purchase date
- All Parts: 3 Years from original purchase date.

Architectural Specifications:

ERV shall be ceiling or wall mount type with built-in speed selectors for both Supply and Exhaust air. Available in symmetrical duct configurations. Select from 30/50/60/70/80/90/100 with a Hi/Lo speed, occupant controlled Boost capability up to 100 CFM. ERV shall have 102 cfm gross exhaust airflow and 100 cfm net supply airflow at 0.1" w.g. and 0.4" w.g. of static pressure as tested in accordance with HVI 915 and 916 standards. ERV shall have Hi/Lo Speed Occupant Controlled Boost Capability. Power consumption shall be no greater than 81 watts at 0.1" w.g. and 100 watts at 0.4" w.g. static pressure. Adjusted Sensible Recovery Efficiency for heating shall be no less than 83% at 53 CFM net air flow under 32°F (0°C) as tested in accordance with CSA C439-18. Sensible Recovery Efficiency for heating shall be no less than 65% at 57 CFM net air flow under -13°F (-25°C). Total Recovery Efficiency for cooling shall be no less than 60% at 49 CFM net air flow under 95°F (35°C). The supply port damper shall close when outdoor temperatures are < -13°F (-25°C) to prevent freezing of the core. The (2) motors shall be totally enclosed DC brushless motors rated for continuous run. DC motor speed shall automatically increase when the fan senses static pressure to maintain selected CFM. ERV shall incorporate an ASHRAE 62.2 Timing function for code compliance. Power rating shall be 120v/60Hz. Duct diameters shall be no less than 4". ERV can be used to comply with ASHRAE 62.2, Ontario, ENERGY STAR[®] and Novoclimat requirements; LEED, IAP, California Title-24, and WA Energy Code Credits.

Mirror Model ERV Core Technology:

- Indoor and outdoor air passes through Panasonic's capillary core technology. This process tempers supply air while transferring moisture and energy.
- Built in Frost Prevention Mode prevents the core from freezing. Frost Prevention Mode is intuitive and operates without homeowner intervention.
- Core material permeated with anti-mold treatment.

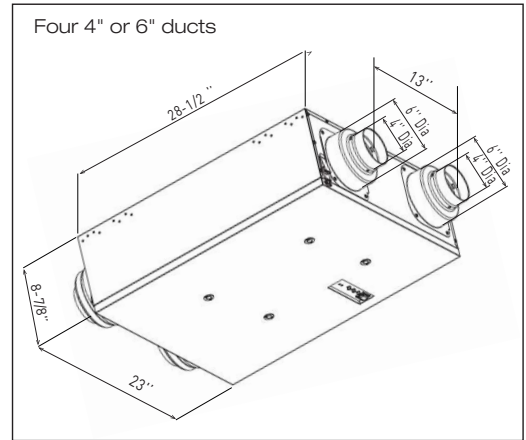

FV-10VEC2R

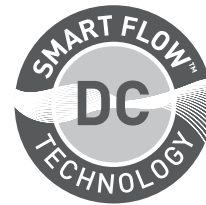
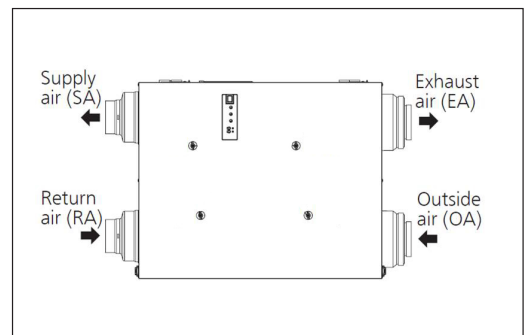

DC Motor Technology

When the ERV senses static pressure, its speed is automatically increased to ensure that the desired CFM is not compromised.

For complete Installation Instructions visit na.panasonic.com/us/iaq

Model	Quantity	Comments	Project:
			Location:
			Architect:
			Engineer:
			Contractor:
			Submitted by:
			Date:

Panasonic IAQ Division

Two Riverfront Plaza
Newark, NJ 07102

na.panasonic.com/us/iaq



*This product meets strict energy efficiency guidelines set by Natural Resources Canada and is ENERGY STAR[®] certified for the Canadian market only.

Panasonic

Specification Submittal Data / Panasonic Mirror Model ERV (Continued)

Specifications: Intelli-Balance 100 FV-10VEC2R			
Static Pressure in inches w. g.	0.1	0.4	
Net Exhaust Air Volume (CFM)	100	100	
Net Supply Air Volume (CFM)	100	100	
Power Consumption (watts)	81	90	
Power Rating (V/Hz)	120/60		
ENERGY STAR [®] Certified	Yes		

Energy Performance: Intelli-Balance 100 FV-10VEC2R							
Supply Temperature		Net Air Flow		Power Consumed (Watts)	Sensible Recovery Efficiency	Adjusted Sensible Recovery Efficiency	Net Moisture Transfer
°C	°F	L/S	CFM				
Heating							
0	32	25	53	29	80	83	78
0	32	31	66	39	77	81	74
0	32	40	85	68	73	77	71
-25	-13	27	57	77	65	67	71
-25	-13	30	64	100	56	60	58
Cooling				Total Recovery Efficiency			
35	95	23	49	32	60		

Performance Curve 4" or 6" duct

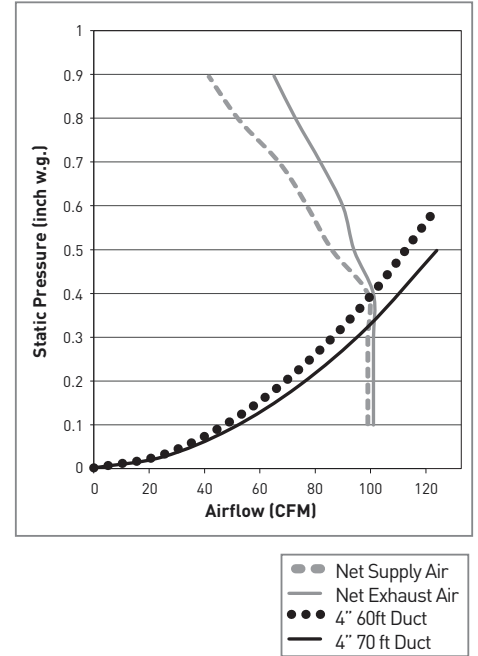

Intelli-Balance 100 Family

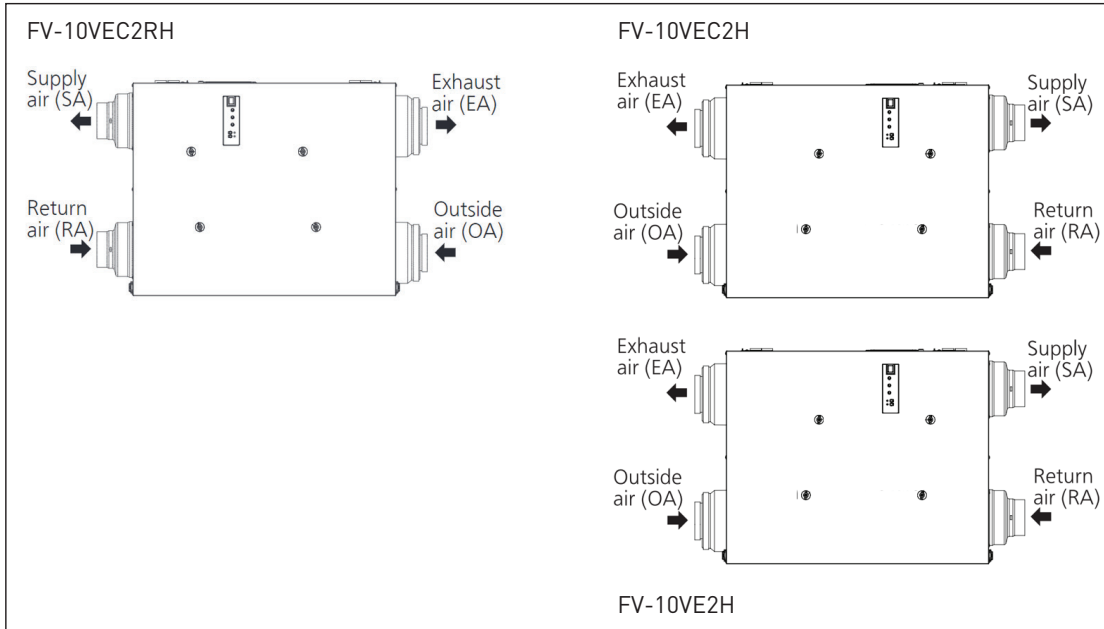

Panasonic
IAQ Division
Two Riverfront Plaza
Newark, NJ 07102
na.panasonic.com/us/iaq



*This product meets strict energy efficiency guidelines set by Natural Resources Canada and is ENERGY STAR[®] certified for the Canadian market only.

Panasonic

Specification Submittal Data / Panasonic Mirror Model ERV (Continued)

Mirrored Installation

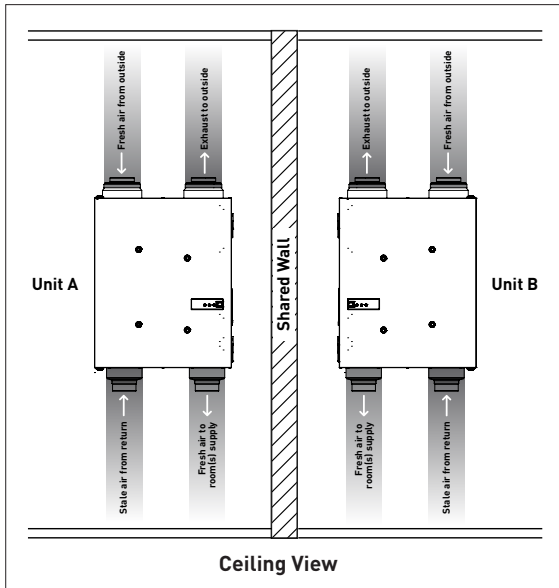

Optional Accessories

WhisperVent[™] Wall Cap

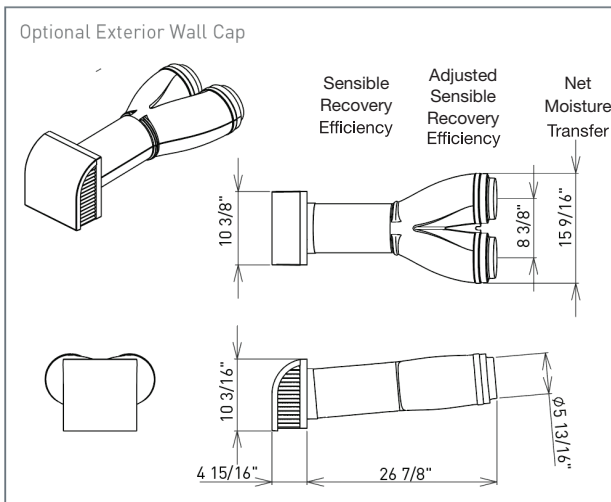

Exterior Wall Cap

FV-WC10VE1 polypropylene wall cap with polystyrene adaptor allows both exhaust (from the right) and supply (from the left) airflow through a 7.5" hole in the building envelope. The dividers inside the bottom portion of the Y shape chamber and the new wall cap shall prevent cross contamination.

Panasonic
IAQ Division
Two Riverfront Plaza
Newark, NJ 07102
na.panasonic.com/us/iaq



*This product meets strict energy efficiency guidelines set by Natural Resources Canada and is ENERGY STAR[®] certified for the Canadian market only.

Panasonic