



WARNING:

Improper installation, setup, modification, operation or maintenance of the heating system can cause personal injury and property damage.

Follow each appliances' instructions precisely.

For assistance or further information, contact a trained and certified installer or service provider.

Application drawings in this manual are conceptual only and do not purport to address all design, installation, code, or safety considerations.

The diagrams in this manual are for reference use by code officials, designers and licensed installers. It is expected that installers have adequate knowledge of national and local codes, as well as accepted industry practices, and are trained on equipment, procedures, and applications involved. Drawings are not to scale.

Bosch Non-Pressurized Flow Centers

NP Series

Part # 7738005098, 7738005099, 7738005102, 7738005103



BOSCH

Installation, Operating, and Maintenance Manual

Table of Contents

General Description	1
Flow Center Sizing	2
Installation	3
Flushing and Purging	5
Start-up12
Maintenance.14
Troubleshooting17
Appendix A: Submittal Data18
Appendix B: Application Drawings.26

Explanation of Symbols

Warnings

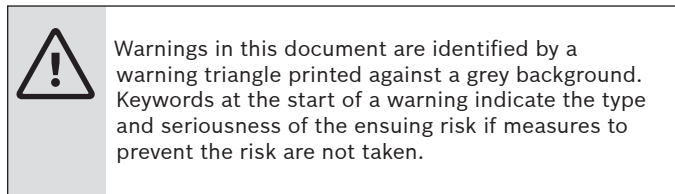

The following keywords are defined and can be used in this document:

- ▶ DANGER indicates a hazardous situation which, if not avoided, will result in death or serious injury.
- ▶ WARNING indicates a hazardous situation which, if not avoided, could result in death or serious injury.
- ▶ CAUTION indicates a hazardous situation which, if not avoided, could result in minor to moderate injury.
- ▶ NOTICE is used to address practices not related to personal injury.

Important information

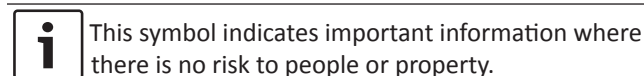

Notes:

This guide provides the installer with instructions specific to NP Series Flow Centers. Please refer to your heat pump manufacturer's instructions or IGSHPA guidelines for additional detailed flushing, purging, and installation information. Please review the entire IOM document before proceeding with the installation.

Bosch Thermotechnology Corp. makes no warranty or representation, expressed or implied, with respect to the accuracy, completeness, or usefulness of this information, nor assumes any liability with respect to the use of any information contained within this document.

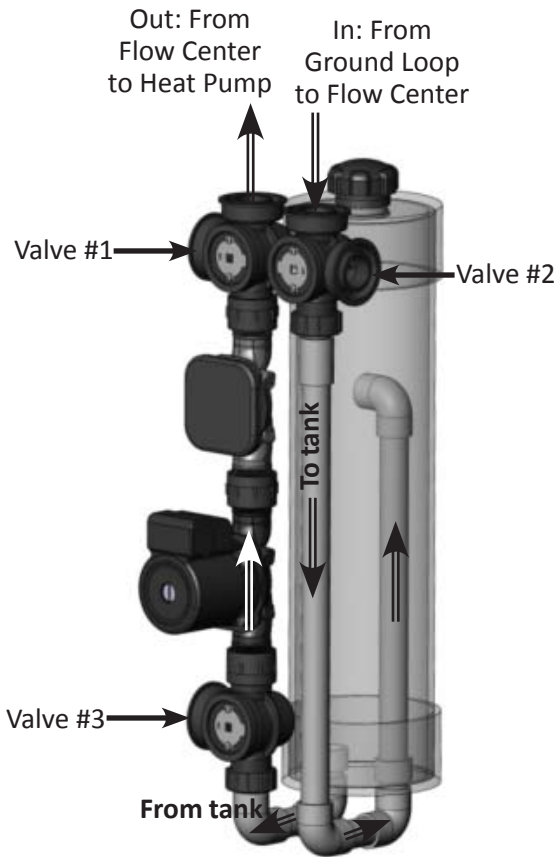

Figure 1: Generalized fluid flow (components inside cabinet)

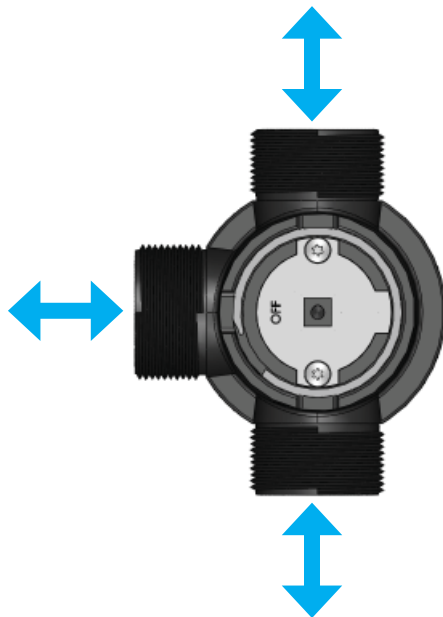

Figure 2: Potential flow paths through 3-way valve

General Description

Flo-Link™ is a trademark of Geo-Flo Products Corporation, Bedford, IN, U.S.A. The NP Series is a family of non-pressurized flow centers used for closed-loop geothermal (ground source) heat pump systems. The NP Series flow centers use a water column to provide the necessary suction head for the circulator pump, and to ensure a flooded pump volute. Each NP Series flow center consists of a fluid reservoir (tank), flush and service valves, and one or more pumps housed in a foam-insulated cabinet. The flow center includes a sealing cap to ensure a closed system while providing integrated pressure and vacuum relief to prevent the reservoir from being over-pressurized or dropping below atmospheric pressure. The NP Series is manufactured with single speed, three speed, and variable speed pumps to provide a variety of options to the contractor and system designer.

Figure 1 shows the fluid flow to and from the NP Series flow center. The valves will be referred to as valve #1, #2, and #3 as labeled in Figure 1 for the purpose of explanation throughout this document. The fluid is pumped from the flow center’s tank on the left side, travels up through the bottom valve (valve #3), through the pump(s), and out the top left valve (valve #1). The fluid returns from the ground loop through the top right valve (valve #2) and is directed to the tank where any air present in the fluid is released. All valves included in the flow center are identical 3-way, 4-position valves. This allows the fluid flow to be stopped or directed as needed for choice of plumbing, flushing/purging, and service. Figure 2 shows the possible flow directions through each valve. The fluid has three potential paths through the valve as indicated by the three threaded ports. The valve spool can be rotated to 4 different positions with a 3/8” square drive tool such as a ratchet wrench. The flow directions on the spool are indicated by the “T” shape on the stainless drive plate. The drive plate is marked with “OFF” which indicates the direction that fluid will not flow. For example, in Figure 2 the OFF position is oriented to the left indicating that flow will not go through this port, and will instead pass straight through the valve. If OFF were turned to the 12 o’clock position, the flow would be directed between the bottom and left side ports.

Flow Center sizing: Performance curves

The specific NP Series flow center should be selected based on the system pressure drop (including the geothermal heat pump, ground loop piping, and interior piping) and desired system efficiency. NP 1 and NP 2 are standard efficiency models while NP V and NP V2 are high efficiency models. The flow center selected should provide at least the minimum amount of flow recommended by the heat pump manufacturer for the heat pump being used. Detailed technical specification documents are available for each NP flow center in Appendix A.

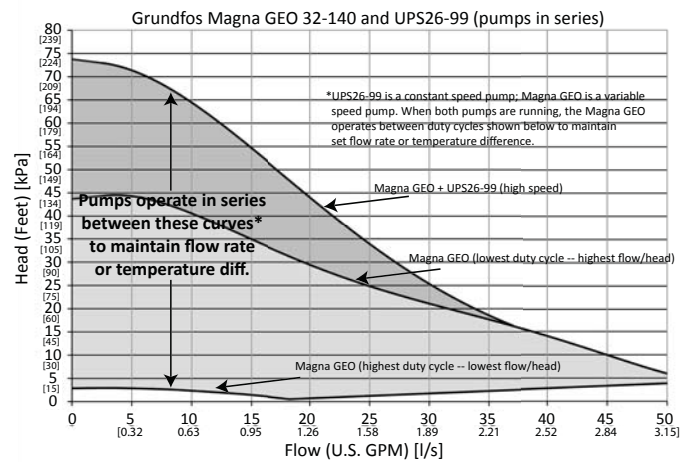
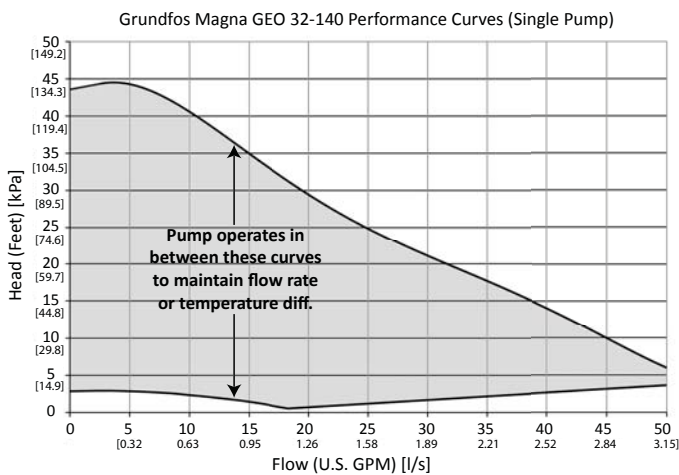
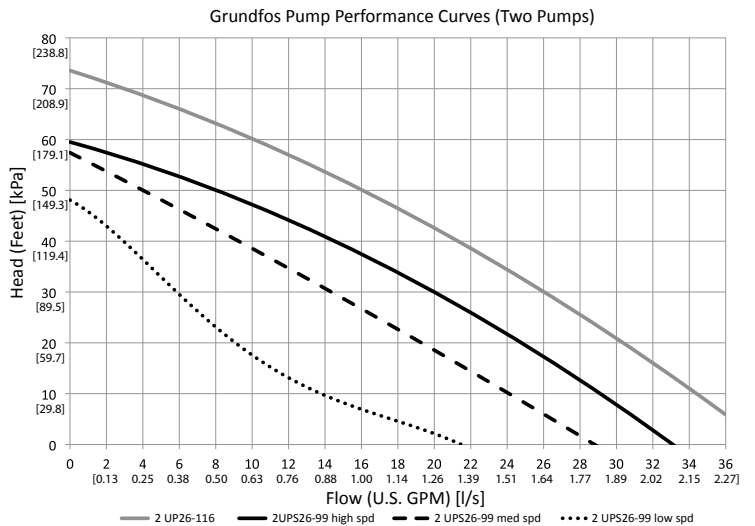
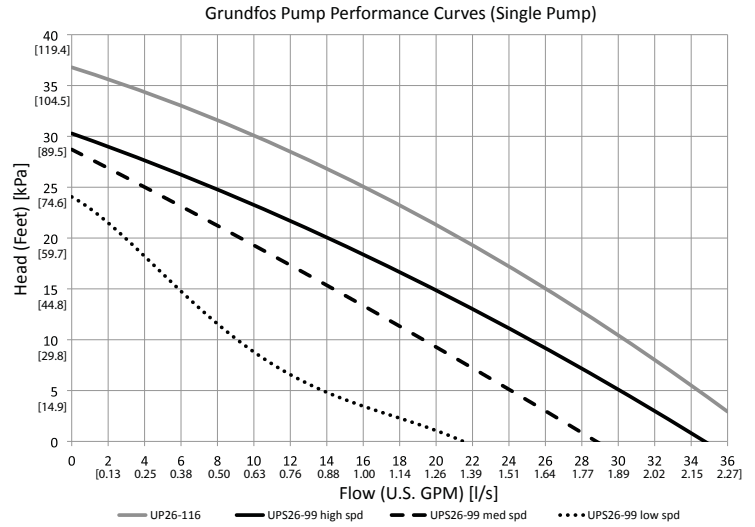

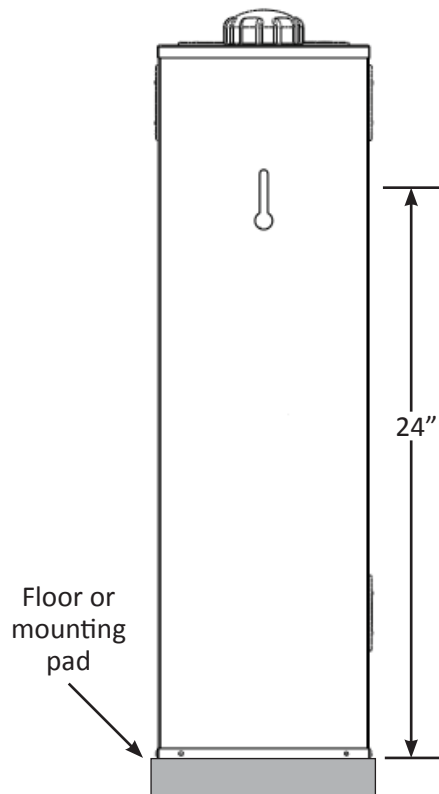

Figure 3: Mounting flow center

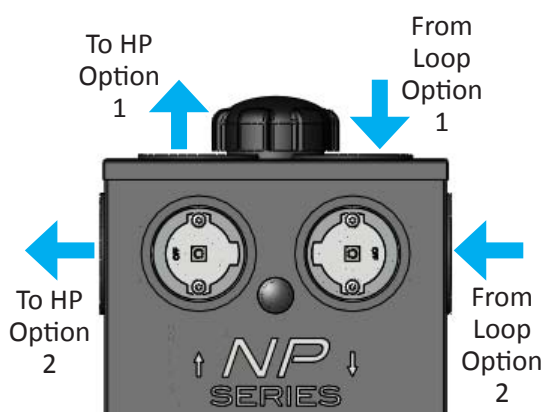

Figure 4: Fluid flow direction options

Installation

Mounting the unit

The NP Series flow center must be mounted on a level surface near the ground source heat pump. The unit can be placed on the floor or on an isolation pad such as a small piece of expanded polystyrene (blue board insulation). A 5/16" lag screw is provided to allow the unit to be secured to a wall. If this method is desired, the screw should be driven into a wall stud approximately 24" above the mounting surface so that a 1/16" gap remains between the wall and base of the screw head (Figure 3). The NP flow center can then be slid into place utilizing the key hole in the back of the unit.

Plumbing Options

The NP flow center can be plumbed with a wide variety of materials including HDPE, PVC, copper, PEX, and flexible hose to provide unlimited options to the installer. The flow directions to and from the flow center are shown in Figure 4. The installer can choose to direct the fluid flow through the top or sides of the flow center depending on how the interior piping is installed. The flow direction is chosen by turning each of the 3-way valves with a 3/8" square drive on a ratchet wrench so that the fluid is directed in the desired way. Flow direction through the 3-way valve is described in the General Description section of this document (page 2).

Figure 5 shows a standard piping configuration utilizing HDPE and a flexible hose transition to the heat pump and unit. This configuration allows simple installation, and vibration isolation between the heat pump, flow center, and ground loop. The optional insulated 3-way valve allows the heat pump to be isolated from the loop, and allows the loop to be flushed independent of the heat pump. This can be useful when the flow center is installed prior to the heat pump. Figure 6 shows a piping configuration utilizing PVC pipe and internal headers. The optional bypass valve(s) allow the ground loop to be isolated from the heat pump. In addition, they allow the ground loop to be flushed independent of the heat pump. Note that the options shown are valid whether inside or outside headers are used.

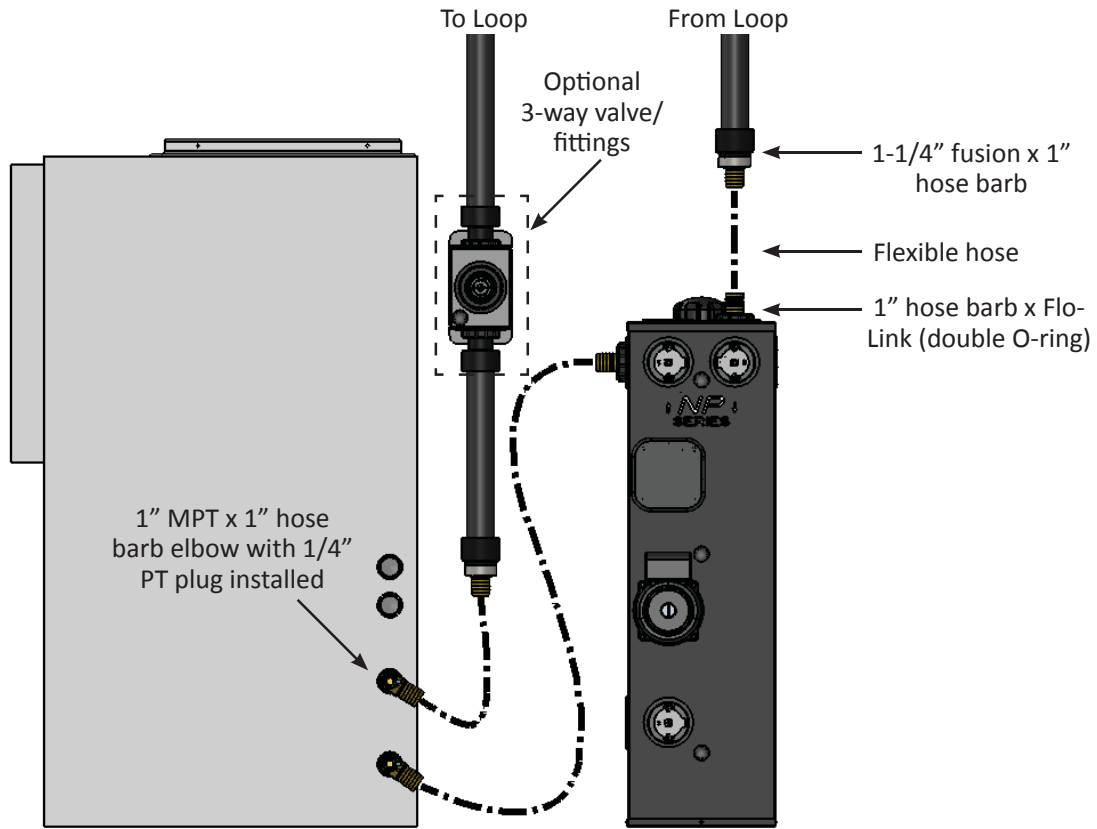

Figure 5: Example of plumbing using a flexible hose transition (hose kit) from the HDPE loop pipe to the NP flow center and heat pump.

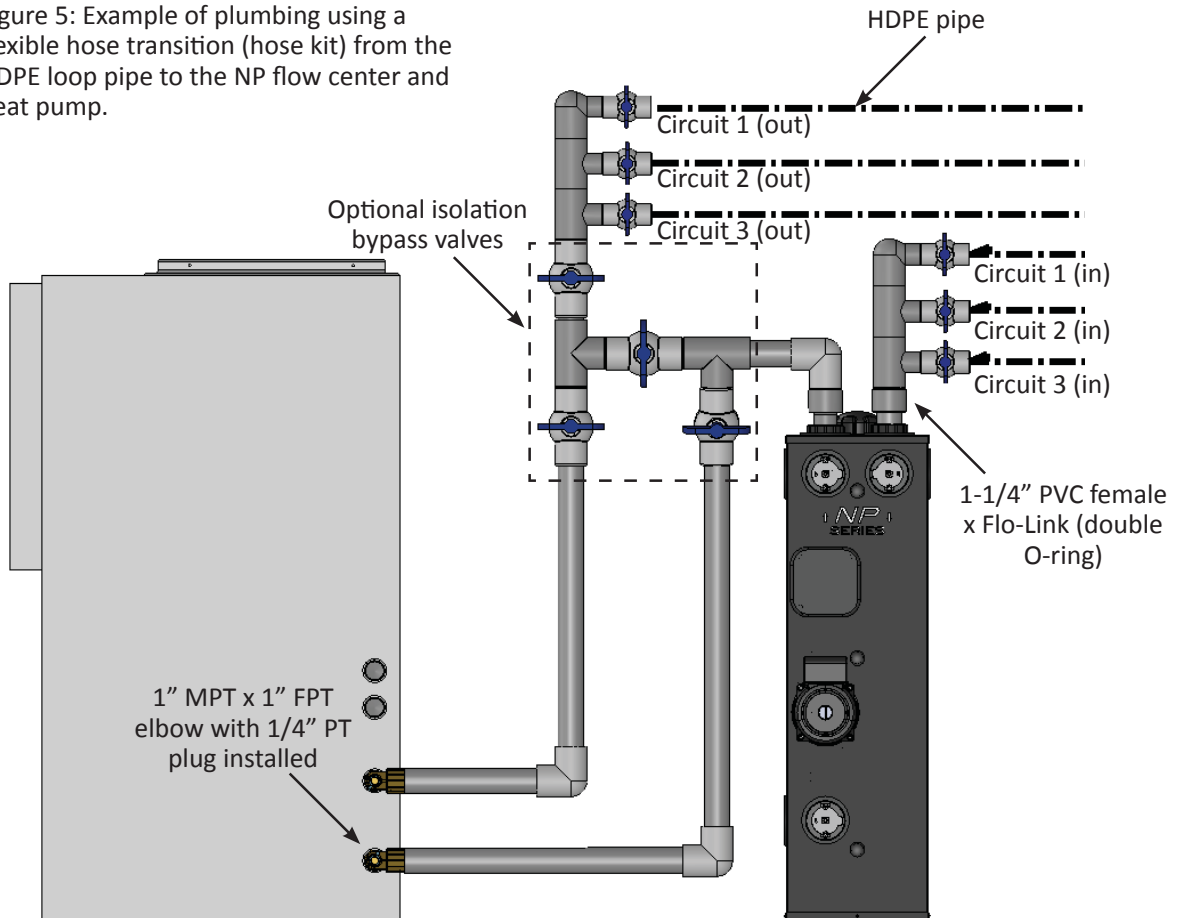

Figure 6: Example of plumbing using PVC for interior piping with inside headers

Flushing and Purging

Flushing with NP Series Flow Center (Outside and Inside Headers)

NOTICE: Using a quality flush cart is the fastest and easiest way to ensure that all air and debris is removed from the ground loop. The flush cart must be able to provide a minimum fluid velocity of 2 ft/s through all piping, provide filtering, and allow power flushing. It is extremely common for construction debris, polyethylene pipe shavings, dirt, sand, rocks, etc. to enter the ground loop piping during installation. The wet rotor circulator pump(s) used during system operation require clean, debris-free fluid to function properly. A small amount of debris in the ground loop could become lodged between the pump's rotor and stator housing causing pump failure a few days to a few years after initial installation. This preventable issue is a common mode of failure for circulators. Although the NP Series flow centers do have the ability to separate air from the loop fluid its pumps are not powerful enough to guarantee that all air and debris can be flushed from every type of loop during the initial loop installation. Bosch recommends flushing all ground loops with a quality flush cart to ensure that the loop is free of air and debris when the loop installation contractor leaves the jobsite.

Many contractors employ non-pressurized flow centers and internal headers to flush the ground loop when a flush cart is not available. Each circuit must be installed with a ball valve to isolate all circuits to allow the flow center pump to flush one circuit at a time. Not all loops may be flushed in this manner, especially those with larger than 3/4" PE circuit piping. The directions in the section Flushing with NP Series Flow Center (Inside Headers) are provided to describe this practice in as thorough manner as possible using the NP Series flow center.

Flushing with Flush Cart



CAUTION:

- ▶ Never dead-head the flush cart pump into the fluid reservoir of the NP Series reservoir tank. Never attempt to flush through the tank using a flush cart Pump. Over-pressurization of the fluid reservoir could be dangerous and will void the warranty.

1. Rotate supply and return valves to bypass the tank. OFF should be in the 6-o'clock position on both valve #1 and #2 (Figure 7).
2. Remove the cap from the NP Series tank. This step is precautionary and intended to protect the flow center from accidental over-pressurization. If the operator places the valves in the incorrect orientation and starts the flush cart, the fluid from the flush cart will quickly fill and overflow the tank.
3. Attach the flush cart to the 3-way valves using Flo-Link double O-ring X 1" CAM fittings (Figure 8). Applying a small amount of lubrication to the O-rings to allow the fittings to be installed and removed with little force (see note on next page). The plastic nuts should be hand-tightened only.



Figure 7: Valve positions for flushing with flush cart. OFF is in 6 o'clock position.

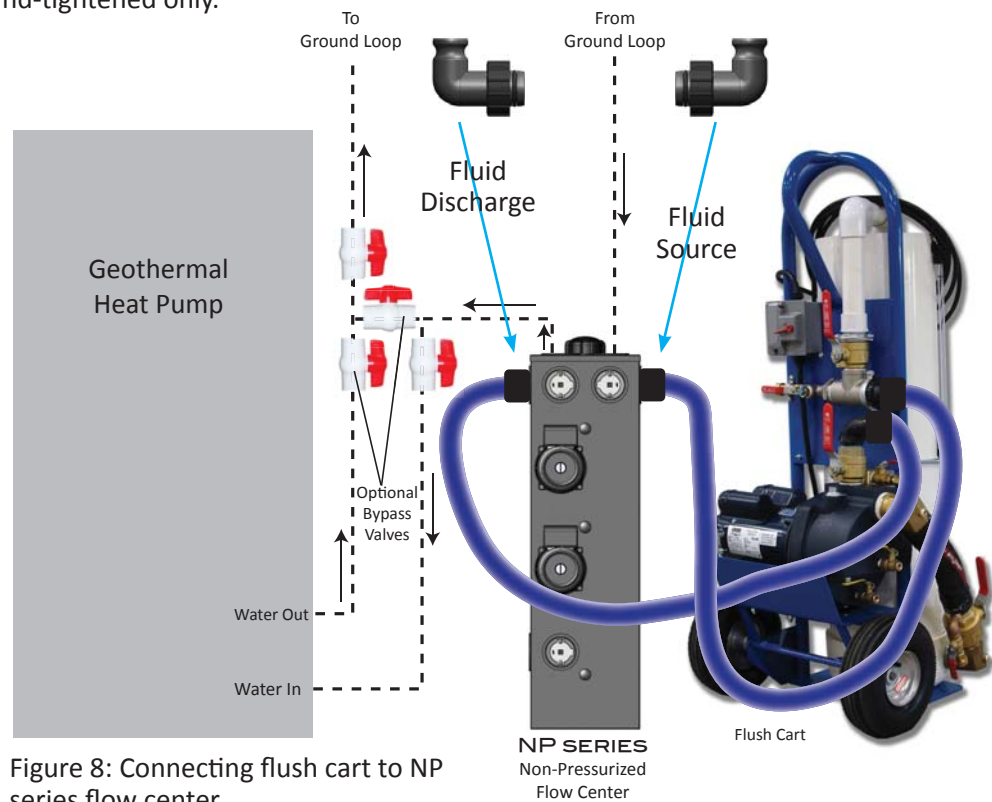

Figure 8: Connecting flush cart to NP series flow center

NOTE: The NBR (nitrile) O-rings used in Bosch valves and on Flo-Link double O-ring fittings are not sensitive to petroleum jelly or silicone based lubricants. However, other types of natural and synthetic rubber can react to petroleum and/or silicone based lubricants. For example, silicone based lubricant should not be used with silicone O-rings or seals. There is no single lubricant than is a perfect solution for every need. Therefore, care should be taken when selecting a lubricant for a particular application.

4. Flush/purge the ground loop and heat pump using a high quality flush cart. The flush cart can be used to flush both the ground loop piping and heat pump/interior piping. The optional bypass valve(s) can be used to flush the ground loop independent of the heat pump if desired.

NOTE: Fluid should not enter the NP Series tank during flushing. If it does, immediately stop the flush cart pump and check to be sure the valves are in the correct orientation as shown in Figure 7.



WARNING:

- ▶ Only use premixed antifreeze in a non-flammable state. Failure to observe safety precautions may result in fire, injury, or death.

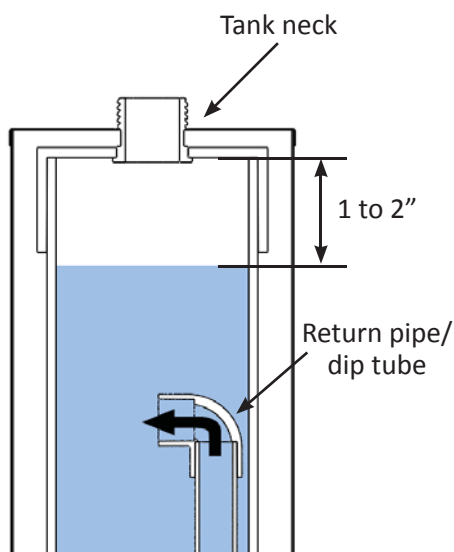

Figure 9: Fluid level of the NP tank (blue shading)

5. Add antifreeze as required.
6. Turn off flush cart. **DO NOT PRESSURIZE LOOP.**
7. Fill the NP Series flow center reservoir with clean, debris free loop fluid. This can be the same pre-mixed fluid that remains in the flush cart after flushing and filling the loop. The tank should be filled to about 1"-2" below the bottom of the tank's neck. Figure 9 shows a cross section of the NP flow center indicating the approximate fluid level.
8. Rotate valves #1 and #2 to the operating position. OFF on the valve face will be turned toward the flush cart connection ports. This could be the top or side ports depending on how the unit is plumbed.
9. Disconnect the flush cart and remove the flush fittings from the flow center.

NOTE: Pull the flush fittings directly out of the valve ports. Do not rock the fittings up and down or side to side or you may crack the valve port and void the warranty.

10. Replace the tank's cap tightening until you hear a "click" similar to an automotive gas cap.

11. Proceed to Start Up section of IOM (page 11)

Flushing with NP Series Flow Center (Inside Headers)

NOTE: If a Geo-Gooser tool is not available, the following procedure can still be followed. However, instead of adding fluid through valve #3, fluid will be added through the top of the tank. In this case, valve #3 will remain in the 9-o'clock position throughout the process. The following instructions assume the NP Flow Center has been plumbed as shown in Figure 5. If the flow center has been plumbed with discharge and/or return pipes in the sides of the flow center, the valve positions described will vary. It is important to understand the flow through the valves before proceeding. See the General Description on page 2 of this IOM for detailed description of the valves' operation.

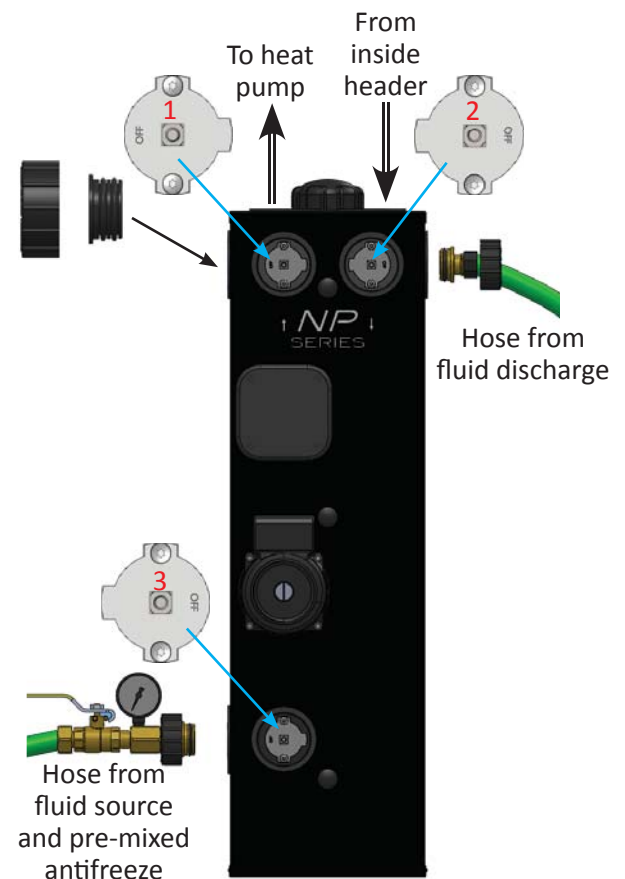

Figure 10: Flushing with inside header



WARNING:

- ▶ Open the main power supply disconnect switch and secure it in an open position prior to performing electrical work. Verify that power has been disconnected prior to wiring the pump(s). Failing to secure the electrical supply could result in serious injury or death.

1. Wire the circulator pump(s) to a control switch to allow the pump to be powered on and off as needed during the flushing process.
2. Remove the cap from the NP Series tank.
3. Cap the unused port on discharge side of the flow center with a double O-ring plug seal and cap (Figure 10). This will prevent accidental discharge through the valve during the flushing process.

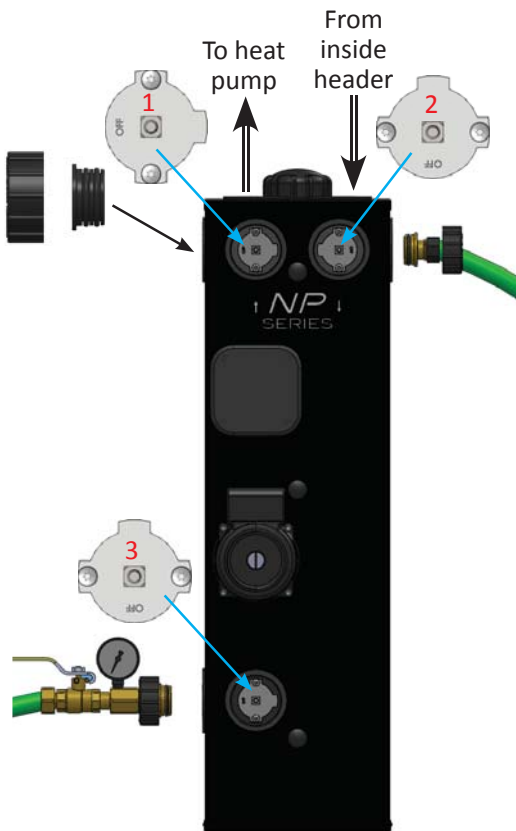

Figure 11: Filling each circuit with fluid

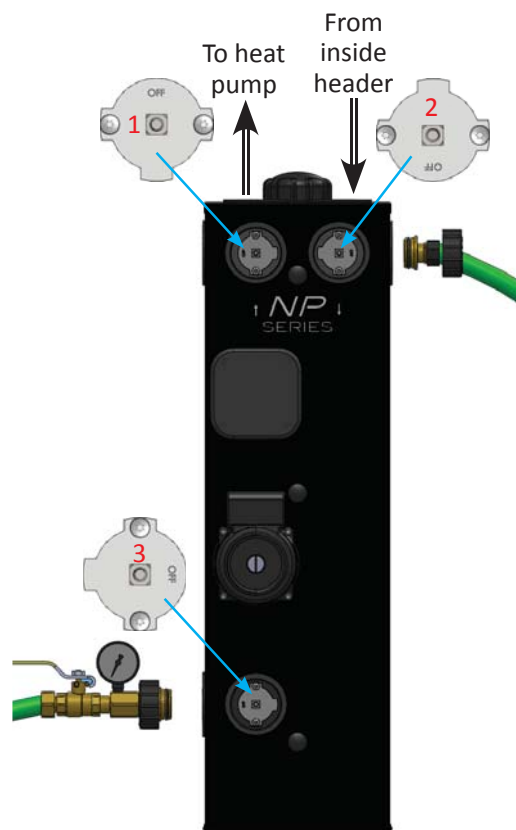

Figure 12: Purging air from the individual circuits

4. Attach a Geo-Gooser tool with garden hose adapter to valve #3 on the flow center and a discharge hose to valve #2 as shown in Figure 10. The supply end of the hose should be connected to a clean water supply source, or to a transfer pump and pre-mixed antifreeze source.
5. Rotate OFF on valve #3 to the 3-o'clock position to allow the tank to be filled with fluid (Figure 10). Open the fluid supply and Gooser ball valve to allow the tank to fill. Once the tank is full, close the Gooser ball valve.
6. Open the vent screw in the center of the UP(S)26 series pump motor with a large flat head screwdriver allowing a few drops of fluid to drip out. Then, retighten the vent screw. If fluid does not exit the vent screw, rotate valve #1 so OFF is at 6-o'clock and open the Gooser ball valve. This pressurizes the plumbing up to valve #1 which will help force fluid from the pump motor.

NOTE: Step #6 is critical. Opening the vent screw and allowing fluid to drip out ensures that all trapped air has exited the pump motor. Skipping this important step could lead to premature pump failure.

7. Close all but one of the loop circuits on the internal header.
8. Rotate valves #1 through #3 as shown in Figure 11. These valve positions will direct the fluid from the source to the loop and back through the discharge hose.
9. Open the Gooser ball valve and fill the loop circuit. Continue filling until fluid returns through the discharge hose and the loop fluid is clean and debris free, and then close the ball valve. Do not direct dirty fluid into the tank.
10. Rotate valve #1 so that OFF is in the 12-o'clock position. This prevents fluid from the loop from returning to the flow center tank (Figure 12).
11. Rotate valve #3 so that OFF is in the 3-o'clock position. This opens the valve to the tank, pump, and supply hose (Figure 12).
12. Direct the discharge hose into the top of the tank, or rotate valve #2 so that OFF is in the 3-o'clock position. Either of these actions directs the return fluid into the tank (Figure 12).

NOTE: The pump(s) can push fluid much more quickly than can be supplied by most domestic water supply sources. Therefore, if valve #1 is completely opened it is possible for the tank to empty very quickly even if the Gooser ball valve is completely open to the source.

13. Energize the pump(s). Slowly open valve #1 by turning counter-clockwise; OFF will go from the 12 o'clock position toward the 9-o'clock position. This allows fluid from the tank to be pumped to the loop circuit. Air will be discharged into the tank as it is pushed from the loop. Monitor the fluid level in the tank and open the Gooser ball valve to supply additional fluid as needed to prevent the tank from being completely emptied.
14. When the fluid level in tank remains constant, close the Gooser ball valve and rotate valve #1 to the 9-o'clock position. This directs the full fluid flow to the loop circuit. If using 3-speed UPS26-99 pump(s), be sure they are running full-speed. If using the Magna GEO variable speed pump, disconnect the control plug to allow the pump to run at full speed.
15. Check the fluid level in the tank and add additional fluid, if necessary, by opening the Gooser valve.
16. While the pump is running, rotate valve #2 counter clockwise to the 12-o'clock position to "dead-head" the pump. If the fluid level drops more than one to two inches, air remains in the circuit and continued flushing is necessary. Rotate valve #2 back to its prior position.

NOTE: Any air in the loop is compressed when the pump(s) is running. Therefore, if air is in the loop and the pump is de-energized the air will expand pushing fluid back into the tank which can cause it to overflow. The pump should only be de-energized when the loop circuit is completely purged of air.

17. Close the individual circuit's ball valve and de-energize the pump(s).
18. Repeat steps 7 through 17 to purge each individual circuit and the heat pump.

19. After each circuit has been flushed individually, open all circuits and allow the pump(s) to run at full speed. Dead-head the pump by rotating valve #2 counterclockwise to the 12 o'clock position while monitoring the fluid level in the tank to be sure all air has been purged. If the fluid level drops more than one to two inches, air remains in the loop and purging must continue. Repeat steps 7 through 17 as needed.
20. De-energize the pump. The fluid in the tank should only rise slightly. If the tank overflows there is air in the loop and purging must continue. It may be necessary to repeat the process of isolating and purging each individual circuit.

**WARNING:**

- ▶ Only use premixed antifreeze in a non-flammable state. Failure to observe safety precautions may result in fire, injury, or death.

21. Add antifreeze to the loop, if necessary. This is accomplished by adding the antifreeze to the loop while removing the same volume of water. Antifreeze is added either through the top of the tank, or via the Gooser tool with garden hose adapter. The antifreeze is pumped to the loop while water is removed through valve #2 and a discharge hose.
22. Proceed to Start Up section of this document.

START-UP



WARNING:

- ▶ Open the main power supply disconnect switch and secure it in an open position prior to performing electrical work. Verify that power has been disconnected prior to wiring the pump(s). Failing to secure the electrical supply could result in serious injury or death.

1. Wire the circulator pump(s) to the heat pump or controller as required.
2. Rotate NP Series flow center valves to the correct operating positions. The positions will depend on which ports were used for plumbing the flow center. OFF for valve #1 will be in either the 9- or 12-o'clock position, OFF for valve #2 will be in the 3- or 12-o'clock position, and OFF for valve #3 will be in the 9-o'clock position.
3. Open the vent screw in the center of the pump motor with a large flat head screwdriver allowing a few drops of fluid to drip out. Then, retighten the vent screw.

NOTE: This step is critical. Opening the vent screw and allowing fluid to drip out ensures that all trapped air has exited the pump motor. Skipping this important step could lead to premature pump failure.

4. Start flow center pump(s) and allow system to operate for several minutes. Remove tank's cap and check fluid level adding additional loop fluid, if necessary, while pump(s) are running. Fluid should be about 2" below the bottom of the tank's neck as shown in Figure 9. Replace the cap and tighten until there is an audible "click" similar to an automobile's gas cap.
5. Measure and record the flow rate using one of the methods described in the following section of this document. If using a NP1-99 or NP2-99 with three speed pumps, the flow can be adjusted by changing the pump(s) speed. The flow rate should be within the range suggested by the heat pump manufacturer.



Figure 13: Valve face cover and plug seal/cap

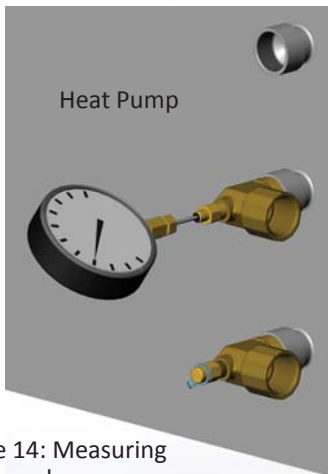

Figure 14: Measuring pressure drop

EWT °F	Flow gpm	WPD	
		PSI	FT
20	3.0	0.9	2.2
	4.5	1.8	4.2
	6.0	2.9	6.8
30	3.0	0.9	2.1
	4.5	1.7	4.0
	6.0	2.8	6.6
40	3.0	0.9	2.0
	4.5	1.7	3.9
	6.0	2.8	6.4
50	3.0	0.9	2.0
	4.5	1.6	3.8
	6.0	2.7	6.2

Figure 15: Example of heat pump manufacturer’s table of pressure drop versus flow rate

6. Verify the performance of the heat pump per the manufacturer’s literature by calculating the heat of extraction and/or rejection (HE-HR). The HE-HR should be within the range specified by the heat pump manufacturer.
7. Replace valve face covers and plug seals (Figure 13). Be sure to lubricate the O-rings on the plug seals to allow for easier removal during future service.

Measuring System Flow Rate

The system flow rate can be determined using two different methods as described below.

Method 1: Flow rate from pressure drop

1. Measure the pressure drop across the heat pump’s heat exchanger via the PT ports located at the water connections of the unit (Figure 14). Use a single large dial face pressure gauge to allow for more precise measurement.
2. Determine the flow rate using the manufacturer’s published tables for pressure drop versus flow (Figure 15).

Method 2: Direct measurement using a Geo-Meter

1. Attach the Geo-Meter to valve #2 using a Flo-Link double O-ring x 1” CAM fitting and direct the flexible hose into the top of the tank (Figure 16).
2. Energize the pump(s).
3. Rotate valve #2 so that OFF is in the 6-o’clock position. This directs the fluid through the Geo-Meter. Be sure the Geo-Meter is vertical.
4. Read the flow rate.



Figure 16: Geo-Meter tool used for flow rate measurement

Maintenance

There is no regularly scheduled maintenance required for the NP Series flow center. However, the fluid level in the tank should be monitored particularly during the first several days after installation or service has been performed.

Replacing circulator pump



WARNING:

- ▶ Open the main power supply disconnect switch and secure it in an open position prior to performing electrical work. Verify that power has been disconnected prior to wiring the pump(s). Failing to secure the electrical supply could result in serious injury or death.

1. Determine whether the circulator pump needs to be replaced. The pump motor should only be replaced after successfully troubleshooting the system and determining that the pump is not functioning. See Troubleshooting section of this document for more information.
2. Rotate OFF on valve #1 to isolate the flow center from the heat pump. This will either be the 9- or 12-o'clock position depending on how the flow center was installed. Remove the cap and plug seal on valve #1.
3. Remove the cap and plug seal on valve #3. Rotate OFF on valve #3 to the 6-o'clock position and capture the fluid that exits valve #3 in a pan. Retain this fluid to add back to the tank after service is complete (Figure 17).
4. Verify that power has been disconnected from the circulator pump(s) using a multimeter.
5. Disconnect wiring from pump.
6. Remove screws holding pump motor to pump housing (volute), and remove the pump motor.
7. Inspect the pump motor and volute for signs that indicate the mode of failure. For example, if debris is present in the pump or

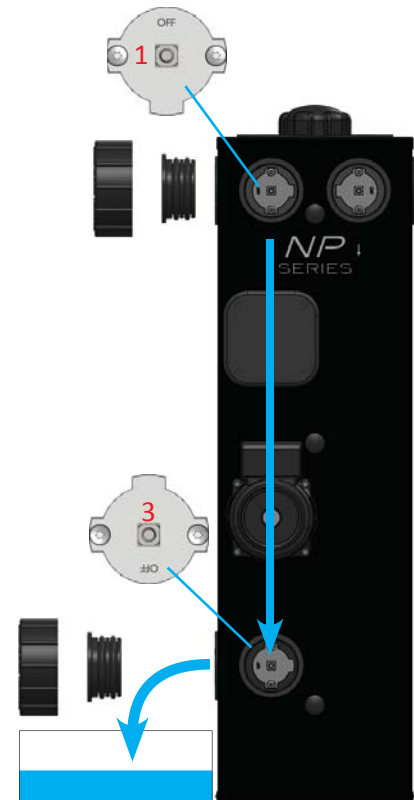

Figure 17: Catching fluid in pump stack when replacing pump motor

volute the ground loop should be re-flushed with a quality flush cart equipped with a filter.

8. Clean the pump seat on the pump housing (volute) with a cloth to remove any debris so that the gasket on the pump will seal properly. Install the new pump motor and reconnect wiring.
9. Replace the plug seal and cap on valve #3. Rotate valve #3 to operating position (OFF in 9-o'clock position). Fluid from the tank will fill the valve/pump stack.
10. Replace the loop fluid that was removed from the system in Step 3. Fill the tank as needed.
11. Rotate valve #1 to the operating position and replace the plug seal and cap on this valve.
12. Open the vent screw in the center of the pump motor just installed with a large flat head screwdriver allowing a few drops of fluid to drip out. Then, retighten the vent screw.

NOTE: This step is critical. Opening the vent screw and allowing fluid to drip out ensures that all trapped air has exited the pump motor. Skipping this important step could lead to premature pump failure.

13. Energize the pump.
14. Verify system performance by checking the flow rate and temperature differential, and comparing the values to the heat pump manufacturer's published data. If installing a UPS26-99, be sure to set the pump speed that provides a flow rate within the manufacturer's recommend range.
15. Remove the tank's cap and check the fluid level. Fluid should be about 2" below the bottom of the tank's neck as shown in Figure 9. Replace the cap and tighten until there is an audible "click" similar to an automobile's gas cap.
16. Replace valve face covers and plug seals as shown in Figure 13. Be sure to lubricate the O-rings on the plug seals to allow for easier removal during future service.

Converting NP1 to NP2 or NPV1 to NPV2

Follow procedure for Replacing Circulator Pump except remove the blank plate instead of the pump motor. Be sure to remove the gasket (Figure 18).

Checking anti-freeze/freeze protection level

The loop fluid may contain antifreeze at concentration high enough to achieve a freeze protection level that is generally 10 degrees lower than the lowest expected entering fluid temperature (EWT) to the heat pump. Antifreeze will be used when the loop fluid entering the heat pump (EWT) is expected to drop below 40 degrees F. The freeze protection level depends on the type and concentration of antifreeze.

Loop fluid can be removed from the NP flow center through one of the three way valves, or through the top of the tank. The specific gravity of the fluid can then be measured with an appropriate specific gravity hydrometer. The specific gravity is used to determine the percentage concentration of antifreeze which is then used to determine the freeze protection level.

Emptying the tank

Valves #1 and #2 should be turned to isolate the NP flow center from the ground loop and heat pump. The tank can be emptied by rotating valve #3 so that OFF is at the 3 o'clock position. A discharge hose can be connected to valve #3 to direct the fluid to a drain or catch basin. Note that the NP Series flow center will hold approximately 3-1/2 gallons of fluid.

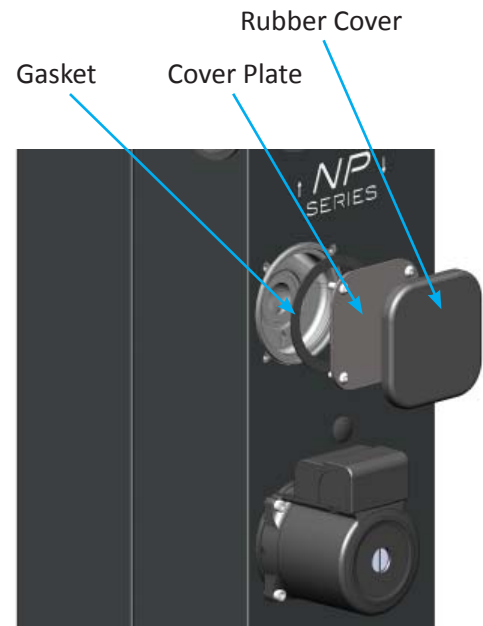



Figure 18: Removing cover plate

Troubleshooting

Problem	Possible Cause	Solution
Water leaks out Cap	Tank over-pressurized	Remove loop fluid
	Cap not sealing	Remove cap; clean reservoir neck and cap gasket; replace cap
		Remove cap; apply lubricant to cap gasket; replace cap
Water leaks out of tank when cap is removed and pump is not energized	Air in loop	Flush system to remove air
	System pressurized	Replace cap quickly; not a problem
Water leaks out valve face	Debris in valve	Rotate valve 360 degrees to dislodge debris
		Remove valve spool; clean valve body and spool; replace O-ring(s) on valve spool if necessary
	Side loading valve spool when rotating with 3/8" drive tool	Rotate valve spool so that no side load is placed on spool
Water drips around O-ring adapter/fittings	Incorrect fitting used (i.e. threaded fitting instead of Flo-Link double O-ring fitting)	Replace incorrect fittings
	Condensation	Insulate piping
	O-ring seal failure	Remove fitting; clean valve port and fittings; replace O-rings if necessary
	Pipe misalignment; side-loading O-rings	Remove fittings; check O-rings and replace if necessary; align piping
Noise in reservoir tank	Air in loop system passing into reservoir	Not a problem. Monitor fluid level; add fluid if necessary
	Low water level in reservoir	Add loop fluid
Low water level in reservoir	Air from loop system deposited into reservoir	Not a problem; add loop fluid
	Pipe expansion	Not a problem; add loop fluid if necessary
	Leak in interior piping	Locate and repair leak
	Leak in ground loop system	Locate and repair leak
No flow to/from tank	Valve(s) in wrong position	Rotate valve(s) to operating position
Air not separating from fluid	Valve(s) in wrong position	Rotate valve(s) to operating position
Pump not operating	No power at pump	Ensure proper power/voltage at pump motor
		Ensure heat pump contacts are operating
		Reset fuse/break in heat pump
	Power at pump but not operating	Remove vent screw and rotate shaft with a small screwdriver. Replace vent screw and re-energize pump.
		Replace pump power head

Appendix A

 	<h3>Submittal Data</h3> NP ¹ non-pressurized flow center, single pump
	Project Name:
	Contractor:
	Engineer:
	Order Number:
Additional Information:	

<h3>Technical Data</h3> Circulator: Grundfos UPS26-99 (3 speed) or UP26-116 (single speed) Cabinet: Powder coated galvanized steel Tank: Polyvinyl chloride (PVC) Insulation: CFC-free polyurethane foam Valves: 1", 3-way, 4-position flushing and isolation/service valve, composite valve body and spool, NBR seals, stainless steel retaining ring		Max. fluid temp.: 140°F [60°C] Min. fluid temp.: 20°F [-7°C] Max. operating press.: 13 psig [89.6 kPa] Max. ambient air temp.: 104°F [40°C]
--	--	--

<h3>Electrical Data</h3> Motor: 230V, 60 Hz, single phase, 2-pole, UL and CSA approved, internal thermal over-load protection, insulation class F								
Part Number	Pump Motor	Speed	Nominal HP	Volts	Amps	Watts	Capacitor	Pump Housing (Volute)
1271	UPS26-99	High	1/6	230	0.9	196	5µF/400V	Cast Iron
		Medium			0.8	179		
		Low			0.7	150		
1273	UP26-116	--	1/6	230	1.8	385	2.5µF/380V	Cast Iron

Approved Antifreeze

- Propylene Glycol
- Methanol
- Ethanol

Mounting

Flow center is designed for indoor installation only.

Flow center must be installed in an upright position as shown to the right.



The pump terminal box should be located in one of the following orientations:

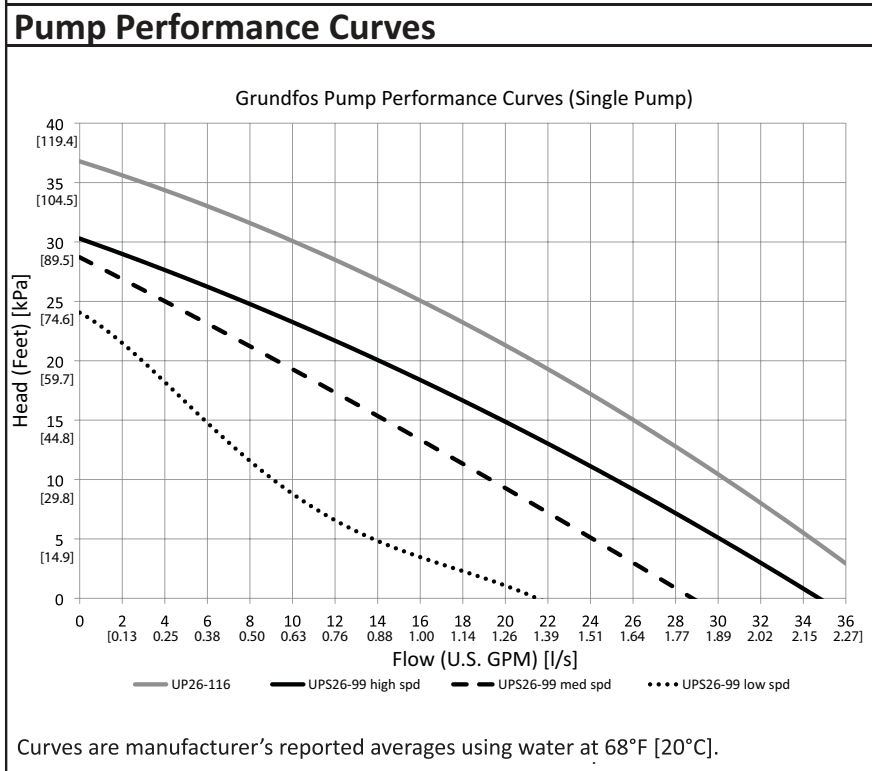
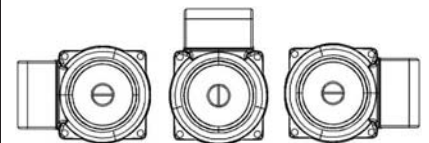





Bosch Thermotechnology Corp.
 50 Wentworth Avenue
 Londonderry, NH 03053
 Tel: 603-552-1100 Fax: 603-965-7581
www.boschheatingandcooling.com

Appendix A

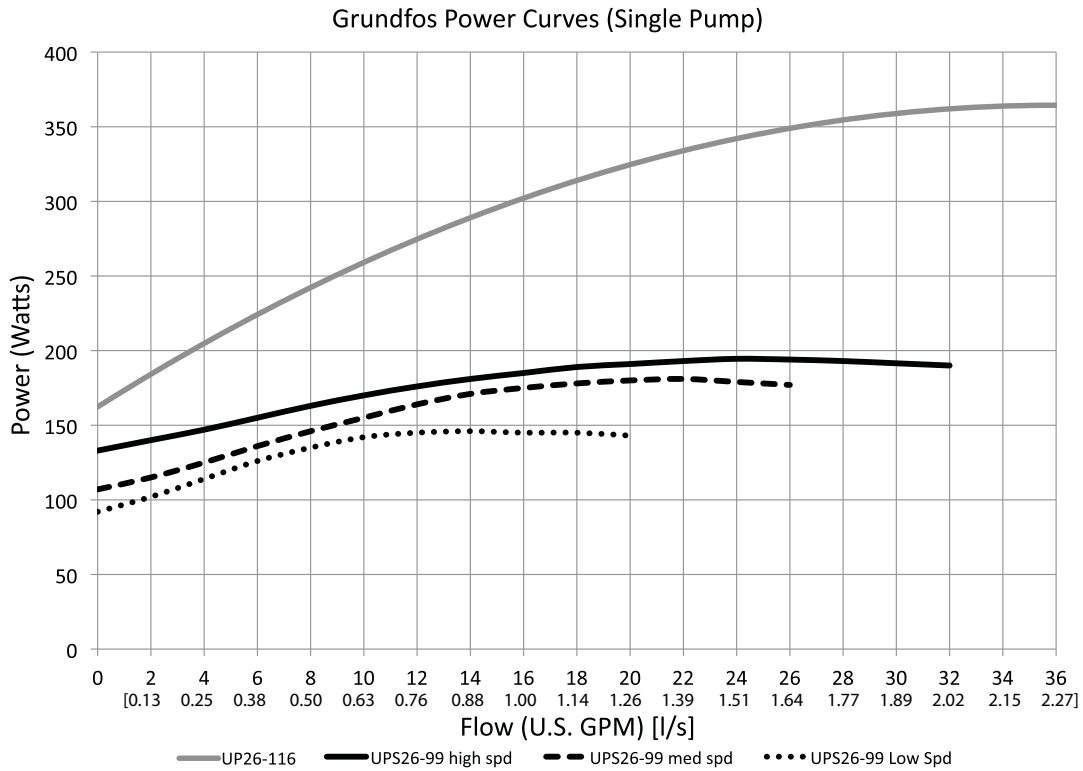
Pump Power Curves



Dimensional Data

	A	B	C	D	E	F	G	H	I	J*	WEIGHT	
Inches	30-1/2	9	11-1/8	16	32	4	9-3/8	24-1/8	4-1/2	3/8" DRIVE SOCKET	LBS	KG
CM	77.4	22.8	28.3	40.7	81.1	10.2	23.9	61.4	11.4		54.0	24.5

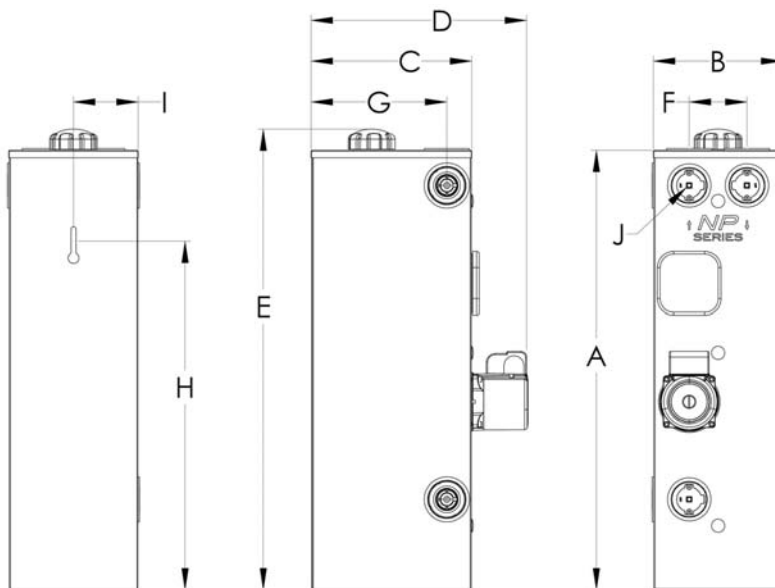

*Requires two Flo-Link™ (double O-ring) transition fittings. Typically, PE fusion or PVC glue fittings are used for the ground loop; a hose kit or PVC glue fitting is used for the heat pump connection.

Flow center may be upgraded to a two pump flow center by removing the blank plate, and adding a second pump.



BOSCH

Bosch Thermotechnology Corp.
 50 Wentworth Avenue
 Londonderry, NH 03053
 Tel: 603-552-1100 Fax: 603-965-7581
www.boschheatingandcooling.com

Appendix A

 <h1 style="color: red; margin: 0;">BOSCH</h1>	<h2 style="margin: 0;">Submittal Data</h2> <p><i>NP²</i> non-pressurized flow center, double pump</p>
	Project Name:
	Contractor:
	Engineer:
	Order Number:
Additional Information:	

<h3>Technical Data</h3>		Max. fluid temp.: 140°F [60°C] Min. fluid temp.: 20°F [-7°C] Max. operating press.: 13 psig [89.6 kPa] Max. ambient air temp.: 104°F [40°C]
Circulators:	Grundfos UPS26-99 (3 speed) or UP26-116 (single speed)	
Cabinet:	Powder coated galvanized steel	
Tank:	Polyvinyl chloride (PVC)	
Insulation:	CFC-free polyurethane foam	
Valves:	1", 3-way, 4-position flushing and isolation/service valve, composite valve body and spool, NBR seals, stainless steel retaining ring	

<h3>Electrical Data</h3>		<h3>Approved Antifreeze</h3>						
Motor: 230V, 60 Hz, single phase, 2-pole, UL and CSA approved, internal thermal over-load protection, insulation class F		Propylene Glycol Methanol Ethanol						
Part Number	Pump Motor	Speed	Nominal HP	Volts	Amps	Watts	Capacitor	Pump Housing (Volute)
1272	UPS26-99 (2 in series)	High	1/6	230	0.9	196	5µF/400V	Cast Iron
		Medium			0.8	179		
		Low			0.7	150		
1274	UP26-116 (2 in series)	--	1/6	230	1.8	385	2.5µF/380V	Cast Iron

NOTE: Above data is maximum per pump.

Approved Antifreeze

Propylene Glycol
Methanol
Ethanol

Mounting

Flow center is designed for indoor installation only.



Flow center must be installed in an upright position as shown to the right.

The pump terminal box should be located in one of the following orientations:

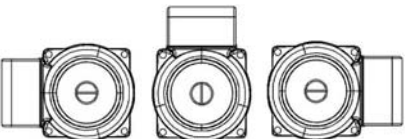

Pump Performance Curves

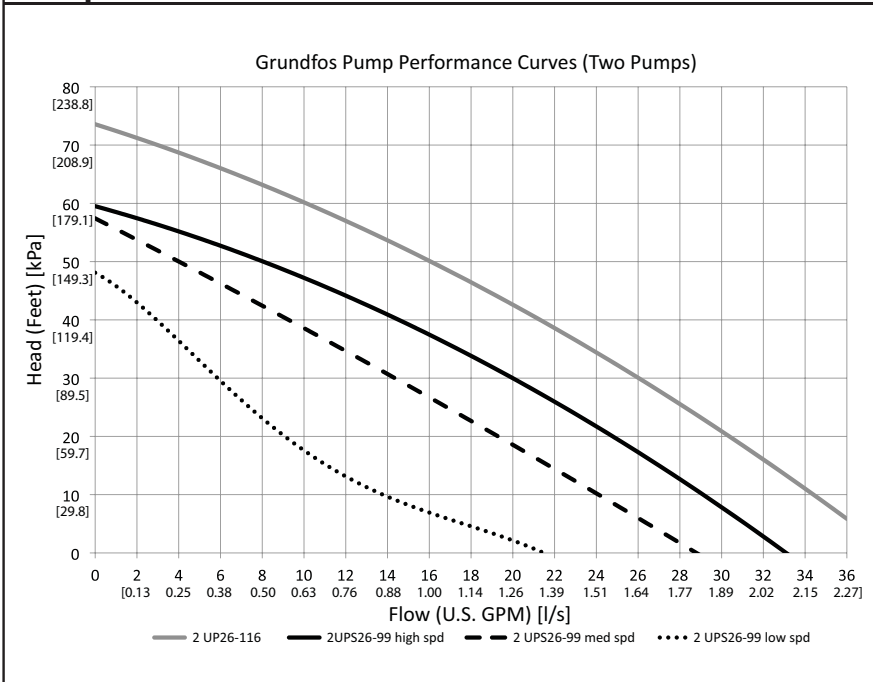

Curves are manufacturer's reported averages using water at 68°F [20°C].



BOSCH

Bosch Thermotechnology Corp.
 50 Wentworth Avenue
 Londonderry, NH 03053
 Tel: 603-552-1100 Fax: 603-965-7581
www.boschheatingandcooling.com

Appendix A

Pump Power Curves

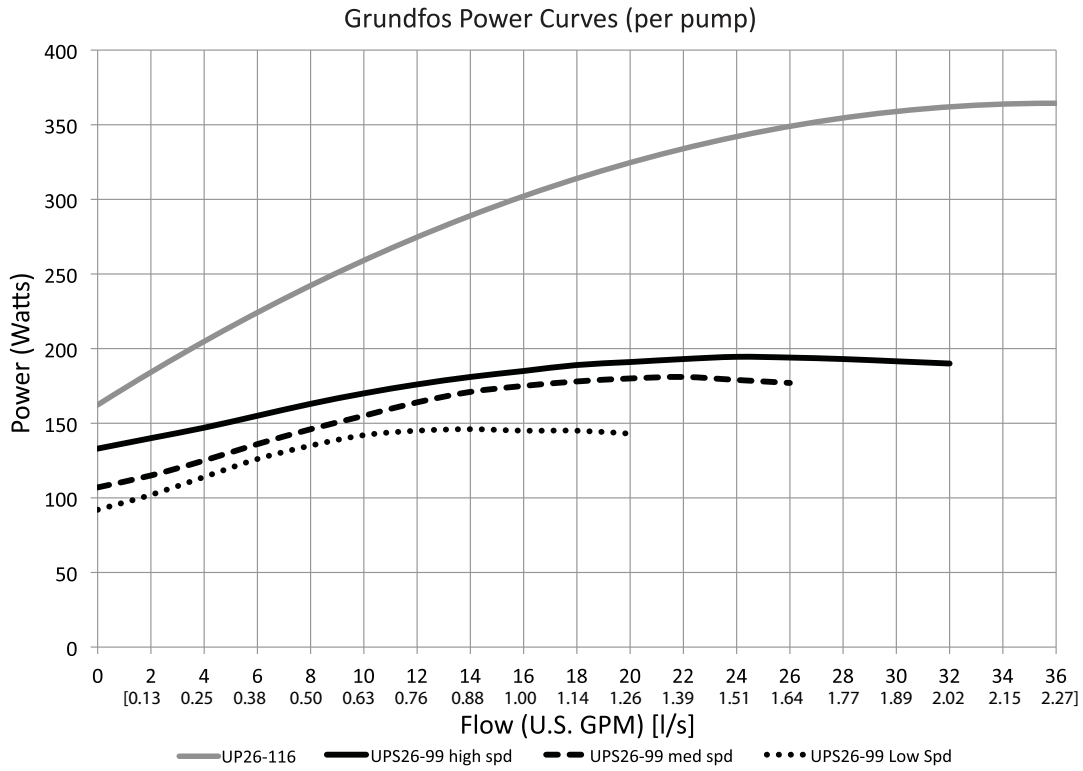

Dimensional Data

	A	B	C	D	E	F	G	H	I	J*	WEIGHT	
Inches	30-1/2	9	11-1/8	16	32	4	9-3/8	24-1/8	4-1/2	3/8" DRIVE SOCKET	LBS	KG
CM	77.4	22.8	28.3	40.7	81.1	10.2	23.9	61.4	11.4		59.0	26.8

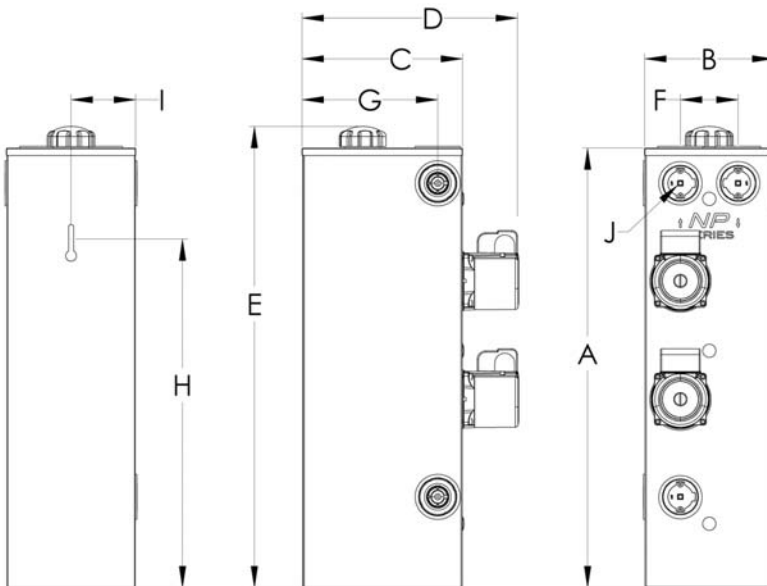

*Requires two Flo-Link™ (double O-ring) transition fittings. Typically, PE fusion or PVC glue fittings are used for the ground loop; a hose kit or PVC glue fitting is used for the heat pump connection.

Flow center may be field modified to a one pump flow center by replacing the second pump with a blank plate.



BOSCH

Bosch Thermotechnology Corp.
 50 Wentworth Avenue
 Londonderry, NH 03053
 Tel: 603-552-1100 Fax: 603-965-7581
www.boschheatingandcooling.com

Appendix A

 <h1 style="margin: 0;">BOSCH</h1>	<h2 style="margin: 0;">Submittal Data</h2> <p style="margin: 0;"><i>NP^V</i> non-pressurized flow center, variable speed pump</p>	
	Project Name:	
	Contractor:	
	Engineer:	
	Order Number:	
Additional Information:		

Technical Data		
Circulator:	Grundfos Magna GEO 32-140 (variable speed--requires controller)	Max. fluid temp.: 140°F [60°C]
Cabinet:	Powder coated galvanized steel	Min. fluid temp.: 14°F [-10°C]
Tank:	Polyvinyl chloride (PVC)	Max. operating press.: 13 psig [89.6 kPa]
Insulation:	CFC-free polyurethane foam	Max. ambient air temp.: 104°F [40°C]
Valves:	1", 3-way, 4-position flushing and isolation/service valve, composite valve body and spool, NBR seals, stainless steel retaining ring	Max. ambient relative humidity: 80%

Electrical and Power Data

Motor: 208-230V, 50/60 Hz, single phase, 2-pole, ETL_{C/US} approved (meets UL and CSA requirements), electronically protected, insulation class F, 0.09 to 1.7 Amps (at 230V)

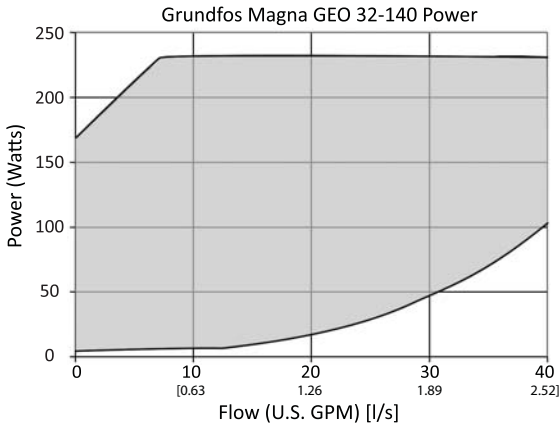

Grundfos Magna GEO 32-140 Power

NOTES: The Magna GEO (variable speed) pump adjusts speed (when used with controller) to maintain flow rate or temperature difference. For Watts based upon a specific flow rate and pressure drop, go to www.geo-flo.com, and use the pump sizing calculator.

Approved Antifreeze
Propylene Glycol
Methanol
Ethanol

Mounting

Flow center is designed for indoor installation only.

Flow center must be installed in an upright position as shown to the right.



The pump terminal box should be located in one of the following orientations:

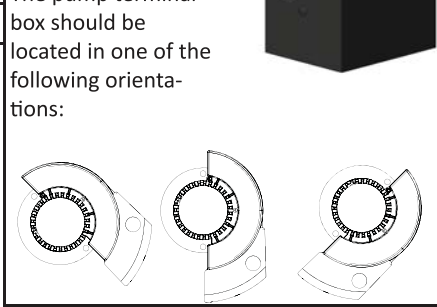

Pump Performance Curves

Grundfos Magna GEO 32-140 Performance Curves (Single Pump)

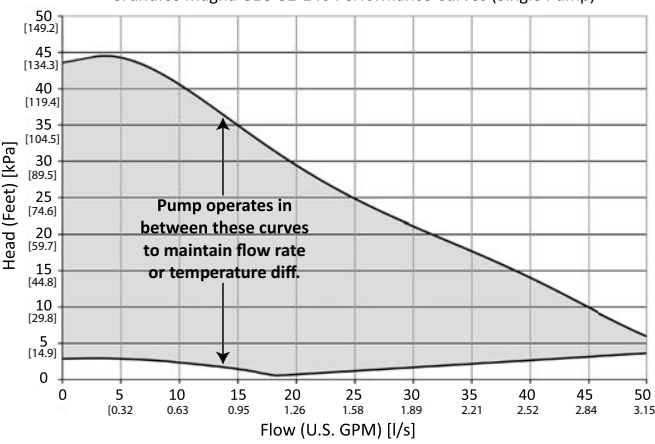

Pump operates in between these curves to maintain flow rate or temperature diff.

Curves are manufacturer's reported averages using water at 68°F [20°C].



BOSCH

Bosch Thermotechnology Corp.
 50 Wentworth Avenue
 Londonderry, NH 03053
 Tel: 603-552-1100 Fax: 603-965-7581
www.boschheatingandcooling.com

Appendix A

Dimensional Data

	A	B	C	D	E	F	G	H	I	J*	WEIGHT	
Inches	30-1/2	9	11-1/8	16	32	4	9-3/8	24-1/8	4-1/2	3/8" DRIVE SOCKET	LBS	KG
CM	77.4	22.8	28.3	40.7	81.1	10.2	23.9	61.4	11.4		51.0	23.1

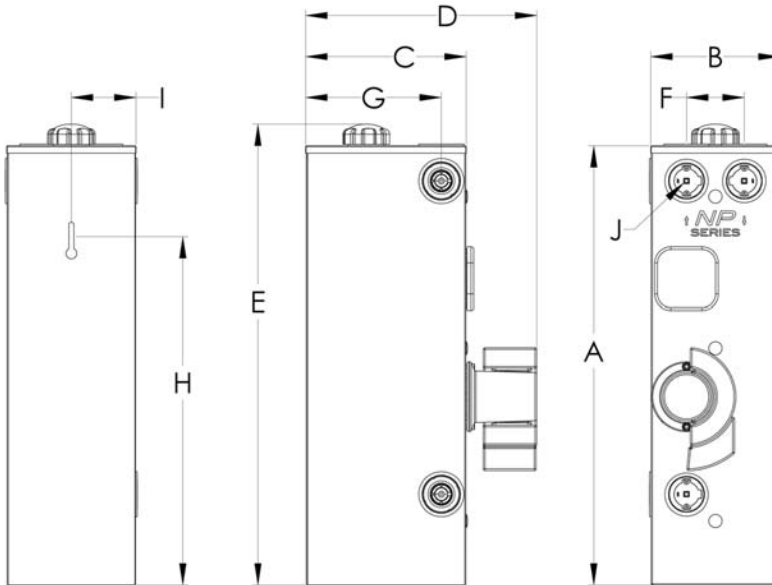

*Requires two Flo-Link™ (double O-ring) transition fittings. Typically, PE fusion or PVC glue fittings are used for the ground loop; a hose kit or PVC glue fitting is used for the heat pump connection.



Flow center may be upgraded to a two pump flow center by removing the blank plate, and adding a second constant speed pump (UPS26-99).



BOSCH

Bosch Thermotechnology Corp.
 50 Wentworth Avenue
 Londonderry, NH 03053
 Tel: 603-552-1100 Fax: 603-965-7581
www.boschheatingandcooling.com

Appendix A

 <h1 style="color: red; margin: 0;">BOSCH</h1>	<h2 style="margin: 0;">Submittal Data</h2> <p><i>NP^{V2}</i> non-pressurized flow center, variable speed, double pump</p>
	Project Name:
	Contractor:
	Engineer:
	Order Number:
	
Additional Information:	

Technical Data

Circulators:	Grundfos UPS26-99 & Magna GEO variable speed (requires controller)	Max. fluid temp.: 140°F [60°C]
Cabinet:	Powder coated galvanized steel	Min. fluid temp.: 20°F [-7°C]
Tank:	Polyvinyl chloride (PVC)	Max. operating press.: 13 psig [89.6 kPa]
Insulation:	CFC-free polyurethane foam	Max. ambient air temp.: 104°F [40°C]
Valves:	1", 3-way, 4-position flushing and isolation/service valve, composite valve body and spool, NBR seals, stainless steel retaining ring	Max. ambient relative humidity: 80%

Electrical Data

UPS26-99 motor: 230V, 60 Hz, single phase, 2-pole, UL and CSA approved, internal thermal over-load protection, insulation class F, three speed

Magna GEO motor: 208-230V, 50/60 Hz, single phase, 2-pole, ETL_{C/US} approved (meets UL and CSA requirements), electronically protected, insulation class F, variable speed

Pump Motor	Speed	Nominal HP	Volts	Amps*	Watts*	Capacitor	Pump Housing (Volute)
UPS26-99	High	1/6	230	0.9	196	5µF/400V	Cast Iron
	Medium			0.8	179		
	Low			0.7	150		
Magna GEO	Variable	1/6	208-230	0.09 to 1.7	5 to 230	N/A	Cast Iron

*At 230V

Approved Antifreeze

Propylene Glycol
Methanol
Ethanol

Mounting

Flow center is designed for indoor installation only.

Flow center must be installed in an upright position as shown to the right.



The pump terminal box should be located in one of the following orientations:

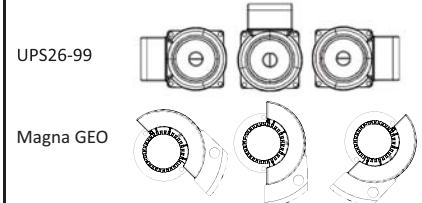

Pump Performance Curves

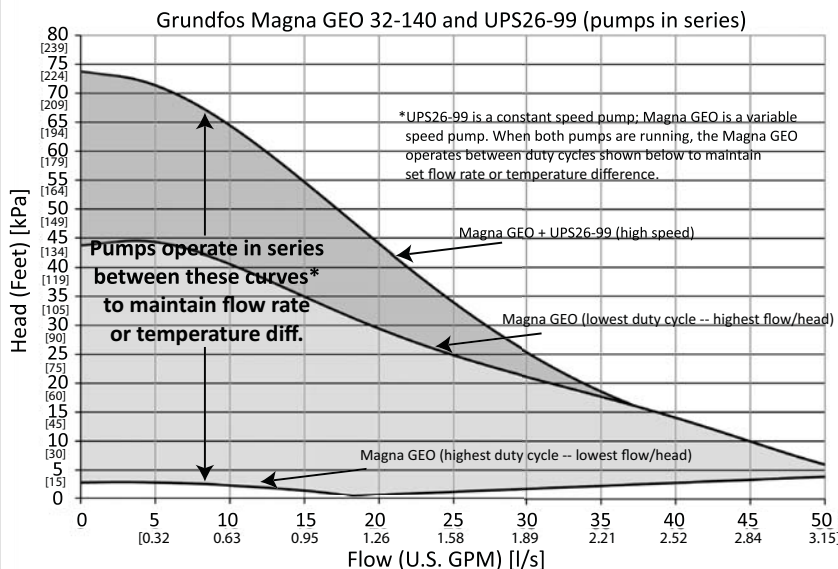

Curves are manufacturer's reported averages using water at 68°F [20°C].



Bosch Thermotechnology Corp.
50 Wentworth Avenue
Londonderry, NH 03053
Tel: 603-552-1100 Fax: 603-965-7581
www.boschheatingandcooling.com

Appendix A

Pump Power Curves

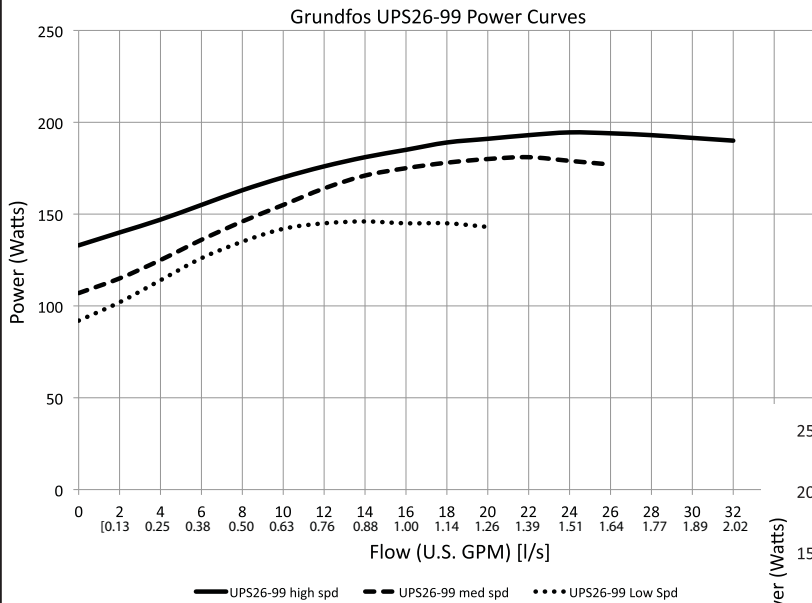

NOTES: The Magna GEO (variable speed) pump adjusts speed (when used with controller) to maintain flow rate or temperature difference. The controller energizes the constant speed pump (UPS26-99) when the Magna GEO cannot meet setpoint, and adjusts the Magna GEO pump accordingly. Total flow center Watts equals constant speed pump Watts plus Magna GEO Watts at design conditions. For Watts based upon a specific flow rate and pressure drop, go to www.geo-flo.com, and use the pump sizing calculator.

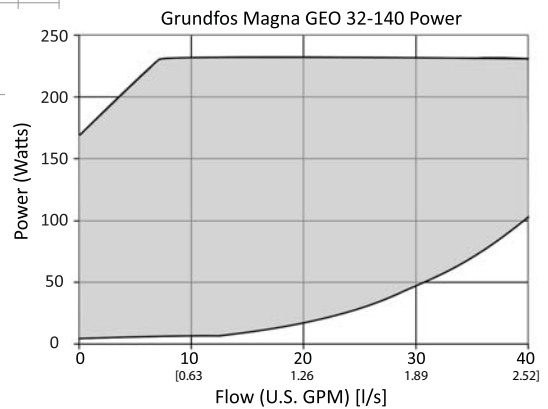

Dimensional Data

	A	B	C	D	E	F	G	H	I	J*	WEIGHT	
Inches	30-1/2	9	11-1/8	16	32	4	9-3/8	24-1/8	4-1/2	3/8" DRIVE SOCKET	LBS	KG
CM	77.4	22.8	28.3	40.7	81.1	10.2	23.9	61.4	11.4		56.0	25.4

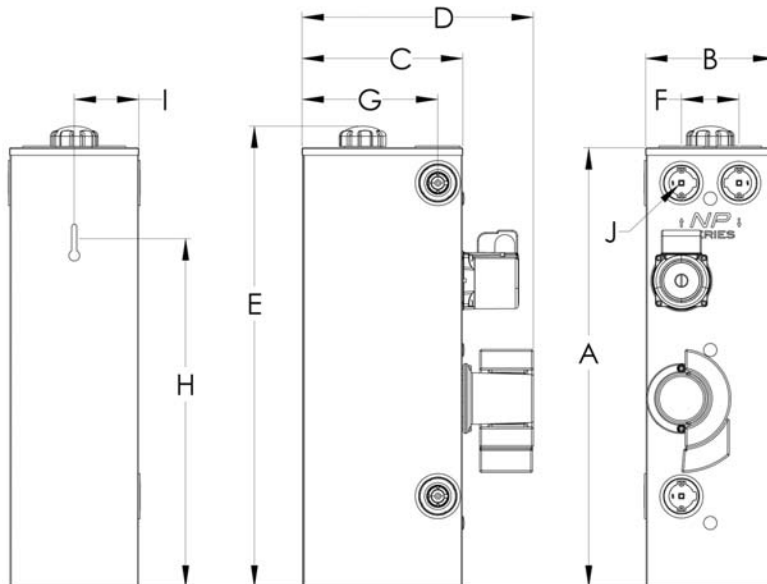

*Requires two Flo-Link™ (double O-ring) transition fittings. Typically, PE fusion or PVC glue fittings are used for the ground loop; a hose kit or PVC glue fitting is used for the heat pump connection.

Flow center may be field modified to a one pump flow center by replacing the upper constant speed pump with a blank plate.



Bosch Thermotechnology Corp.
 50 Wentworth Avenue
 Londonderry, NH 03053
 Tel: 603-552-1100 Fax: 603-965-7581
www.boschheatingandcooling.com

Appendix B: Application Drawings

Outside Header / Hose Kit / Side Connections



Appendix B: Application Drawings

Outside Header / Hose Kit / Side & Top Connections

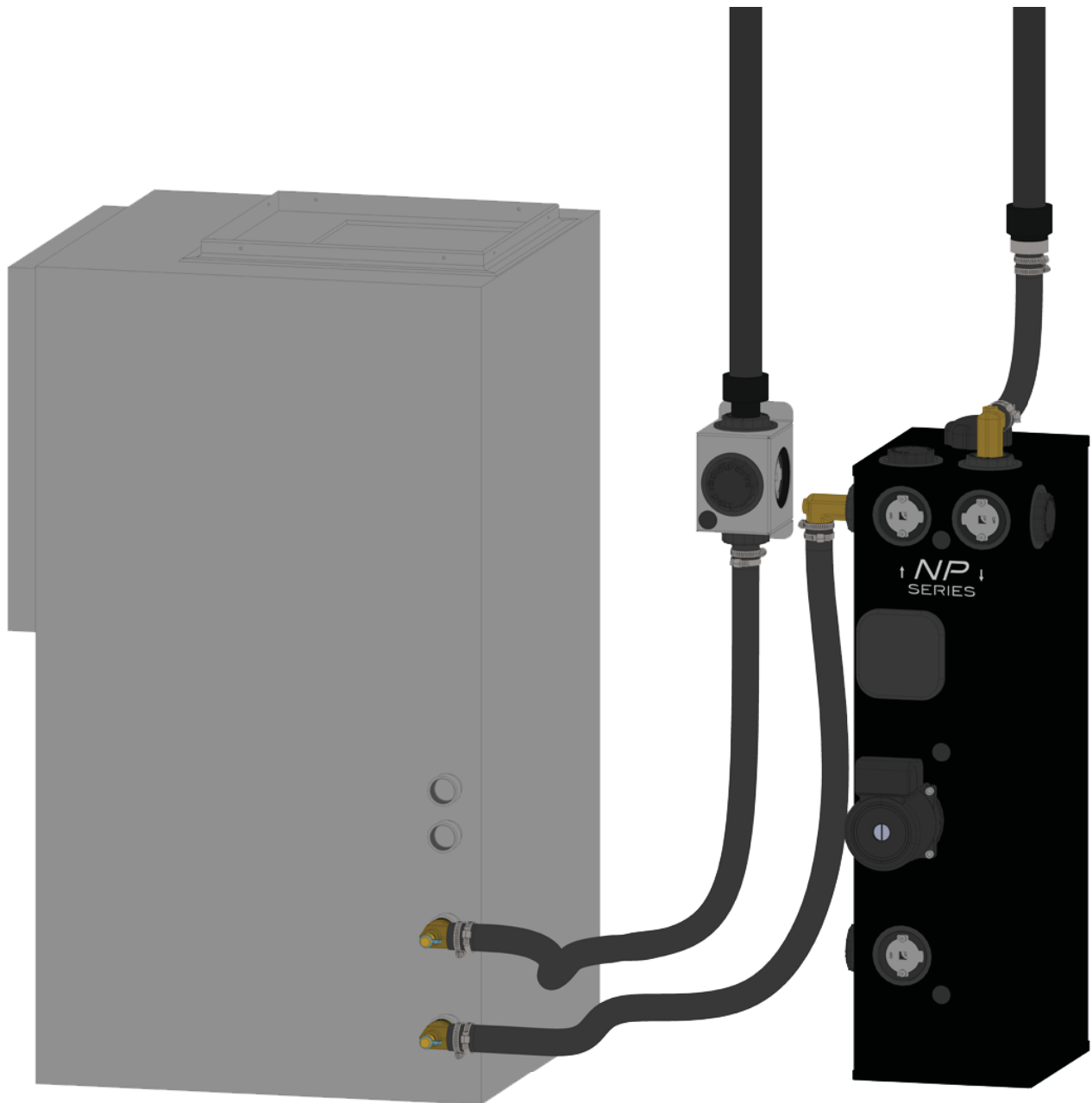

Appendix B: Application Drawings

Inside Header - PVC Piping

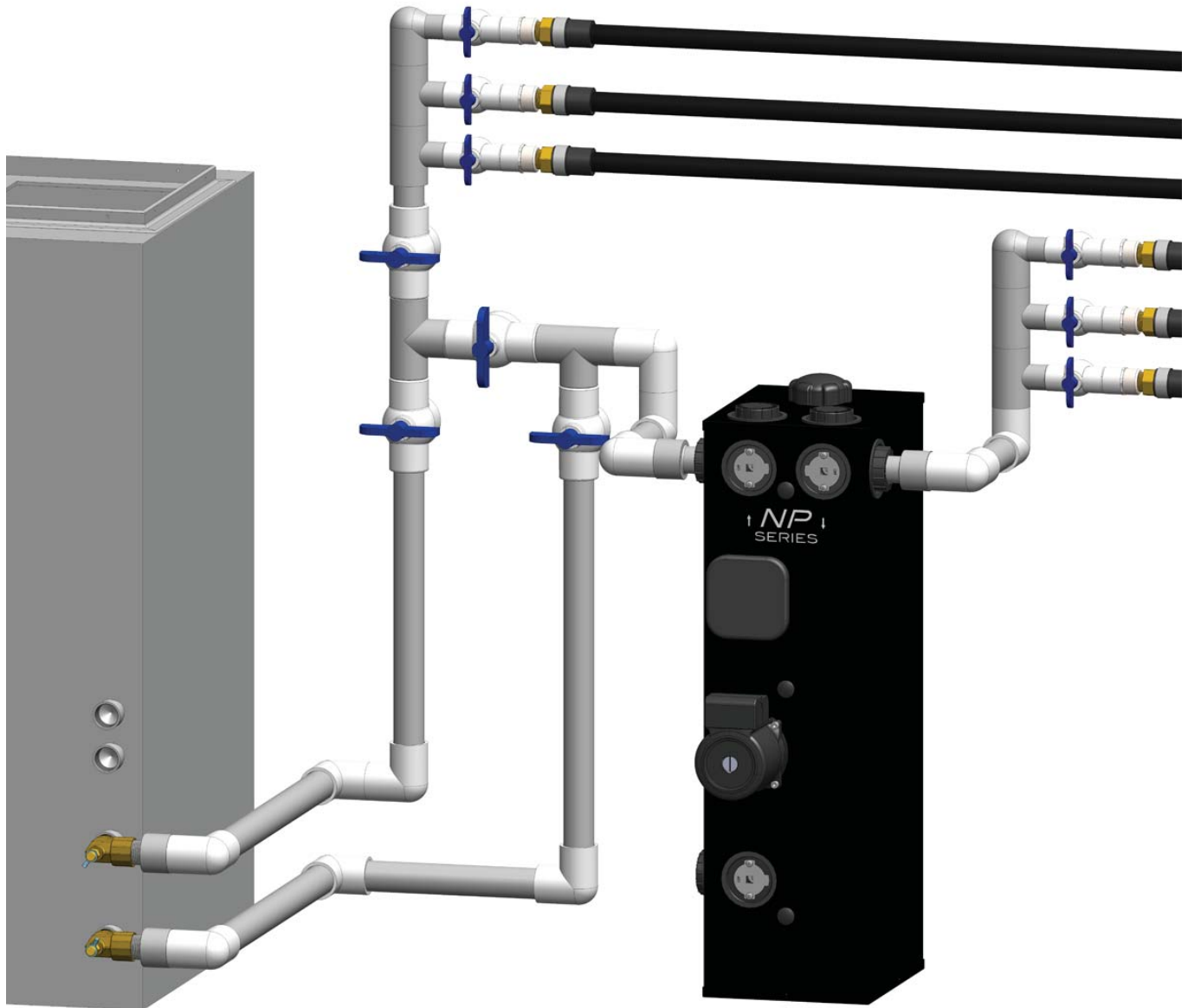

NOTES

Bosch Thermotechnology Corp.
50 Wentworth Avenue
Londonderry, NH 03053

Tel: 603-552-1100
Fax: 603-965-7581
www.boschheatingandcooling.com

For Technical Support:
Tel: 866-642-3198